

Lifting machine series



3D big scissor type double-layer four-wheel positioning lift

Model: UE-3.5MS/3D
 power supply: 380V/3PH or 220V/1 PH
 Gas source: 6~ 8kg/cm³
 power: 2.2KW
 Capacity: 3.5T
 Lifting height: 330-1850mm
 Child lifting height: 450mm



Ultra-thin big shear flat four-wheel positioning lift

Model	Power supply	Gas source	power	Capacity	Lifting height	Secondary lift weight	Secondary lifting height
UE-3.5M418	380v/3ph or 220v/1ph	6-8kg/cm ²	2.2kw	3.5T	180-1860mm	2T	375mm
UE-4.0M418	380v/3ph or 220v/1ph	6-8kg/cm ²	2.2kw	4.0T	180-1860mm	2T	375mm
UE-4.5M418	380v/3ph or 220v/1ph	6-8kg/cm ²	2.2kw	4.5T	180-1860mm	3T	375mm
UE-5.5M418	380v/3ph or 220v/1ph	6-8kg/cm ²	2.2kw	5.5T	180-1860mm	3T	375mm

Ultra-thin large scissor type double-layer four-wheel positioning lift

Model	Voltage	Gas source	Power	Capacity	Lifting height	Secondray lifting height
UE-3.5MSL/15	380V/3PH or 220V/1PH	6-8kg/cm ²	2.2kw	3.5T	155-1860mm	460mm
UE-4.0MSL/15	380V/3PH or 220V/1PH	6-8kg/cm ²	2.2kw	4.0T	155-1860mm	460mm
UE-4.5MSL/15	380V/3PH or 220V/1PH	6-8kg/cm ²	2.2kw	4.5T	155-1860mm	460mm
UE-5.5MSL/15	380V/3PH or 220V/1PH	6-8kg/cm ²	2.2kw	5.5T	155-1860mm	460mm



Ultra-thin small scissor flat lift

Model: UE-3.0SL
 Power supply: 380v/3PH or 220v/1PH
 Gas source: 6-8kg/cm²
 Roof length: 1450mm
 Capacity: 3.0T
 Lifting height: 105-1830mm

Lifting machine series



Frame type two-post lift (electromagnetic unlocking)

Model: UE-4.0TPG
 Rack height: 2878mm
 Voltage: 380V/3PH or 220V/1PH
 Power: 2.2kw
 Lifting height: 126-1930mm
 Capacity: 4.0T
 Column inner width: 2780mm

Frame type two-post lift (Manually unlock)

Model: UE-4.0TPFA
 Rack height: 2822mm
 Voltage: 380V/3PH or 220V/1PH
 Power: 2.2kw
 Lifting height: 100-1780mm
 Capacity: 4.0T
 Column inner width: 2760mm



Gantry two-post lift (manually unlocked)

Model	Voltage	Power	Capacity	Lifting height	Column inner width	rack height
UE-3.5PROA	380v/3ph or 220v/1ph	2.2kw	3.5T	100-1780mm	2760mm	3640mm
UE-4.0PROA	380v/3ph or 220v/1ph	2.2kw	4.0T	100-1780mm	2760mm	3640mm

Model	Voltage	Gas source	Power	Lifting weight	Lifting height	Secondary lifting weight(optional)	Secondary lifting height(optional)
UE-3.5F	380V/3PH or 220V/1PH	6-8kg/cm ²	2.2kw	3.5T	170-1770mm	2T	375mm
UE-4.0F	380V/3PH or 220V/1PH	6-8kg/cm ²	2.2kw	4.0T	196-1846mm	2T	375mm
UE-4.5F	380V/3PH or 220V/1PH	6-8kg/cm ²	2.2kw	4.5T	196-1846mm	3T	375mm
UE-5.0F	380V/3PH or 220V/1PH	6-8kg/cm ²	2.2kw	5.0T	196-1846mm	3T	375mm
UE-5.5F	380V/3PH or 220V/1PH	6-8kg/cm ²	2.2kw	5.5T	196-1846mm	3T	375mm
UE-6.5F	380V/3PH or 220V/1PH	6-8kg/cm ²	2.2kw	6.5T	210-1800mm	5T	375mm
UE-8.0F	380V/3PH or 220V/1PH	6-8kg/cm ²	2.2kw	8.0T	245-1830mm	5T/7T	375mm
UE-10.0F	380V/3PH or 220V/1PH	6-8kg/cm ²	2.2kw	10.0T	245-1830mm	5T/7T	375mm
UE-12.0F	380V/3PH or 220V/1PH	6-8kg/cm ²	2.2kw	12.0T	245-1830mm	5T/7T	375mm

Four-post lift



Lifting machine series

Four-post four-wheel positioning lift



Model	Voltage	Gas source	Power	Lifting weight	Lifting height	Secondary lifting weight(optional)	Secondary lifting height(optional)
UE-3.5F4	380V/3PH or 220V/1PH	6-8kg/cm ²	2.2kw	3.5T	220-1820mm	2T	375mm
UE-4.0F4	380V/3PH or 220V/1PH	6-8kg/cm ²	2.2kw	4.0T	246-1896mm	2T	375mm
UE-4.5F4	380V/3PH or 220V/1PH	6-8kg/cm ²	2.2kw	4.5T	246-1896mm	3T	375mm
UE-5.0F4	380V/3PH or 220V/1PH	6-8kg/cm ²	2.2kw	5.0T	246-1896mm	3T	375mm
UE-5.5F4	380V/3PH or 220V/1PH	6-8kg/cm ²	2.2kw	5.5T	246-1896mm	3T	375mm
UE-6.5F4	380V/3PH or 220V/1PH	6-8kg/cm ²	2.2kw	6.5T	255-1845mm	5T	375mm
UE-8.0F4	380V/3PH or 220V/1PH	6-8kg/cm ²	2.2kw	8.0T	260-1845mm	5T/7T	375mm
UE-10.0F4	380V/3PH or 220V/1PH	6-8kg/cm ²	2.2kw	10.0T	260-1845mm	5T/7T	375mm
UE-12.0F4	380V/3PH or 220V/1PH	6-8kg/cm ²	2.2kw	12.0T	2600-1845mm	5T/7T	375mm

Small Scissor Flat Lift (SUV)

Model	Voltage	Gas source	Power	Roof length	Capacity	Lifting height
UE-3.0S	380V/3PH OR 220V/1PH	6-8kg/cm ²	2.2kw	1440-1740mm	3.0T	330-2160mm
UE-3.5S	380V/3PH OR 220V/1PH	6-8kg/cm ²	2.2kw	1440-1740mm	3.5T	330-2160mm
UE-4.5S	380V/3PH OR 220V/1PH	6-8kg/cm ²	2.2kw	1440-1740mm	4.5T	330-2160mm



Ultra-thin small scissor plate lift with lifting plate

Model: UE-3.0SLE
 Power supply: 380v/3PH or 220v/1PH
 Gas source: 6-8kg/cm²
 Roof length: 1550-2118mm
 Capacity: 3.0T
 Lifting height: 105-1830mm



Small Scissor Flat Lift (Single Stretch)

Model	Voltage	Gas source	Power	Roof length	Capacity	Lifting height
UE-3.0S	380V/3PH OR 220V/1PH	6-8kg/cm ²	2.2kw	1440-1740mm	3.0T	330-2160mm
UE-3.5S	380V/3PH OR 220V/1PH	6-8kg/cm ²	2.2kw	1440-1740mm	3.5T	330-2160mm
UE-4.5S	380V/3PH OR 220V/1PH	6-8kg/cm ²	2.2kw	1440-1740mm	4.5T	330-2160mm

Lifting machine series



Small Scissor Flat Lift (Double Stretch)

Model: UE-3.0SB/3.5SB/4.5SB
Power supply: 380v/3PH or 220v/1PH
Gas source: 6-8kg/cm²
Roof length: 1450-2040mm
Capacity: 3.0T/3.5T/4T
Lifting height: 330-2160mm

Small Scissor Flat Lift (Double Stretch)

Model: UE-3.0SSE
Voltage: 380V/3PH or 220V/1PH
Gas source: 6-8KG/cm²
Power: 2.2kw
Roof length: 1450-2030mm
Capacity: 3.0T
Lifting height: 105-960mm



Motorcycle lift



UE-166

Lifting capacity: 700kg
Max lifting height: 1200mm / 47"
Min. height: 150mm / 6"
Lifting time: 20S
Overall length for platform: 2220mm / 87"
Overall width for platform: 730mm / 29"
Motor power: 1.5kw
Power supply: 110V/220V/380V/415V
Air supply pressure: 6~ 8bar
Weight: 320Kg
Packing size: 2230* 740*260mm

mini car lift



L27 low profile scissor car Lift

Lifting capacity	2700kg/6000lbs
Max.lifiting height	1200mm
Min.height	110mm
Width	1000mm
Length	1685mm
Lifting time	30s
Motor power	2.2kw
Power supply	110V / 220V / 380V
Air supply	6~8bar
Weight	451kg
Packing Size	2300x1080x270+910x400x470mm

UE-002 Portable car scissor mini lift

Voltage	12v
power	1600w
Lifting weight	≤2.5ton
Reference wheelbase	2.4m~3.2m
Ground clearance	90~400mm



UE-MINI2800/3200 Portable car scissor mini lift



Lifting capacity	2800kg
Lifting height	570mm
Min.height	90mm
Lifting time	20~25s
Motor power	0.75kW
Power supply	12V/DC、 220V、 110V、 380V/50HZ/AC
Oil pressure	18Mpa
Weight	95kg/110kg
Packing Size	1810x310x110x2mm+580x280x270mm

Parking lift

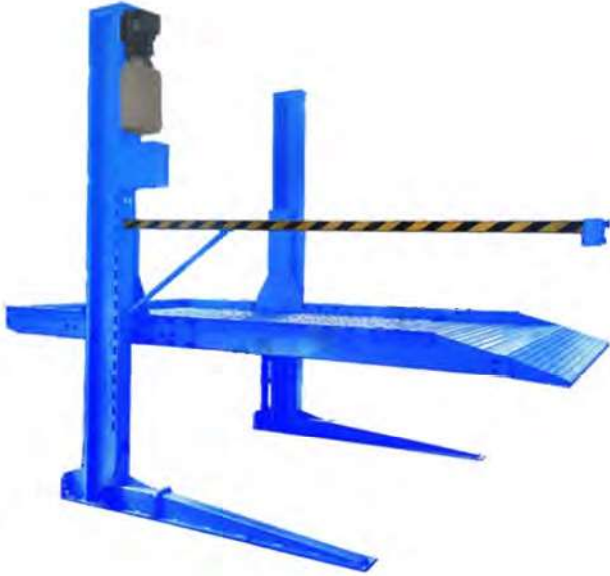

UE-2.8TPB Car Parking Lift

Model	Power	Power	
UE-2.8TPB	380V/3PH or 220V/1PH	2.2kw	
Platform width	Column height	Capacity	Lifting height
4266*2100mm	3320mm	2.8T	2100mm



UE-8000P Car Parking Lift

Lifting capacity	2700kg	Max.parking height under platform	2050mm
Thickness of the platform	115mm	Lifting time	70s
Descent time	60s	Platform length	4165mm
Platform width	2000/2100/2200mm	Motor power	2.2kw
Weight	A:1060kg B:765kg	Packing Size	3780x850x300mm,3800x520x310mm, 1000x270x290mm,2200x760x200mm



UE-105 four-post parking Lift

column height	2819mm
lifting height	2387mm
between column	3119mm
total wide	3347mm
run way long	6200m
lifting capacity	4500kg

Car lift



UE-TRA6000B Mini Tilting Car Lift

Model	UE-TRA6000B
Capacity	1.5 Ton
Max. Height	1100 mm
Package Size	1110x730x300 mm
N.W./G.W.	110/115 kgs
QTY/20'CY	100 PCS
MOQ	5 PCS

UE-118 New energy car Lift

Lifting capacity	220Lbs/1000kg
Max lifting height	27"/700mm
Min height	45"/1150mm
Platform length	49"/1245mm
Platform Width	31"/800mm
Lateral spreads width	35mm
Air Pressure	7kgf/cm ²
Net Weight	300kg



UE-25 Single Post Car Lift



Lifting height	Lifting speed
1800mm	24S

Motor power	Power voltage	Control voltage	Single post weight
1.5KW	380V	24V	750KG

Bus lift



Work site diagram

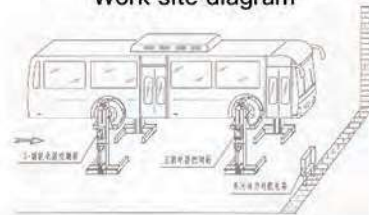

External dimensions of single column lift

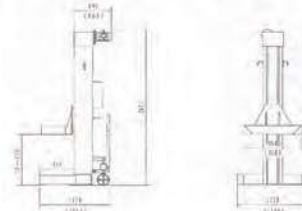

Product parameters

Single column lift weight	5000kg-5500kg	7500kg
Lifting height	~1550mm	~1550mm
Overall lifting length	Not fixed	Not fixed
Lifting working width	Not fixed	Not fixed
The lifting speed	0.6m/min	0.6m/min
The operating voltage	24V	24V
Single column weight	560kg	650kg
The noise index	<60 d B(-)/m	<60 d B(-)/m
Package size	1120*1120*2650mm	1140*1120*2650mm
Operating temperature	5°C- +40°C	5°C- +40°C
The work environment	Both indoor and outdoor use, do not rain operation.	

Main technical parameters of electrical components:

Name	QJZ5.0T-QJZ5.5T	QJZ7.5T
Motor/power	220V-380V-415V-440V/3KW	220V-380V-415V-440V/3KW
Frequency/working voltage	50HZ-60HN /24v	50HZ-60HN /24v
Insulation grade/speed	IP /1400RMP	IP /1400RMP

QJZ5.0 / 7.5 Combined Movable Vehicle Lifter

- Inca lift equipment provides customers with safety and reliability.
- Inca lifts are designed to maximise workshop efficiency and space, while providing the operator with safe and easy to use controls.
- Inca lift's screw lift technology has proven to be the most durable and easy to maintain on the market.
- With a S.W.L from 20 - 80 tons Inca lifts cater for all heavy vehicles jobs a workshop is likely to see.
- Each column is equipped with control system which can operate all posts or switch to operate that single column.
- Mobile and flexible, the system can be used indoors or outdoors.



Parameter	Single stand lifting weight	Lifting Height	Lifting speed	Motor power	Working Voltage	Control Voltage	Length x Width x Height	Single post weight
Type	t	mm	m/min	kw	v	v	mm	kg
QJZ5.0	5.0	1500	0.6	3	380	24	1120x1100x2600	580
QJZ7.5	7.5	1500	0.6	4	380	24	1120x1100x2600	800

Safety

Safety is always the first priority in any workshop and Inca Lifts achieve this in three ways.

1. Mechanically

Each Inca column is driven by a high tensile screw and nut which is backed up by a none drive safety nut. In the case of failure the safety nut supports the weight on the column and all columns are shutdown.

2. Electronically

Each Inca column is fitted with high quality CE marked electronics.

3. Manually

Each Inca column is sold with a secondary fixed stand to support the weight of the vehicle when lifted.

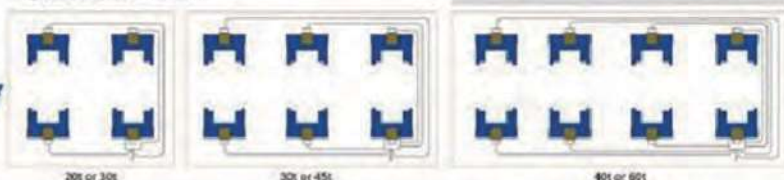
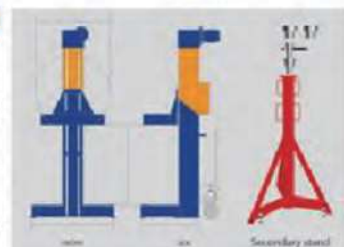

Car lift



UE-L2800 (A)

Single column underground lift

Maximum lifting height: 1850mm
Maximum lifting weight: 3500kg
Foundation depth: 2650mm
Lifting column diameter: 195mm
Lifting column wall thickness: 13mm
Equipped with mechanical lock and hydraulic throttle plate



UE-L2800 (A-1)

Single column underground lift

Maximum lifting height: 1850mm
Maximum lifting weight: 3500kg
Foundation depth: 2650mm
Lifting column diameter: 195mm
Lifting column wall thickness: 13mm
Equipped with mechanical lock and hydraulic throttle plate



UE-L2800 (A-2)

Single column underground lift

Maximum lifting height: 1850mm
Maximum lifting weight: 3500kg
Foundation depth: 2650mm
Lifting column diameter: 195mm
Lifting column wall thickness: 13mm
Configure hydraulic throttle plate



UE-L2800 (F)

Single column underground lift

Maximum lifting height: 1850mm
Maximum lifting weight: 3500kg
Foundation depth: 2650mm
Lifting column diameter: 195mm
Lifting column wall thickness: 13mm
Equipped with mechanical lock and hydraulic throttle plate

Car lift



UE-L2800 (F-1)

Single column underground lift

Maximum lifting height: 1850mm
Maximum lifting weight: 3500kg
Foundation depth: 2650mm
Lifting column diameter: 195mm
Lifting column wall thickness: 13mm
Configure hydraulic throttle plate



UE-L2800 (F-2)

Single column underground lift

Maximum lifting height: 1850mm
Maximum lifting weight: 3500kg
Foundation depth: 2650mm
Lifting column diameter: 195mm
Lifting column wall thickness: 13mm
Support arm length: 4000mm
Equipped with mechanical lock and hydraulic throttle plate
Lift tires; suitable for maintenance and car washing



UE-L4800 (A)

Double column underground lift

Maximum lifting height: 1850mm
Maximum lifting weight: 3500kg
Foundation depth: 2650mm
Lifting column diameter: 140mm
Lifting column wall thickness: 15mm
Double column spacing: 1360mm
Equipped with mechanical lock and hydraulic throttle plate



UE-L4800 (E)

Double column underground lift

Maximum lifting height: 1850mm
Maximum lifting weight: 3500kg
Foundation depth: 2650mm
Lifting column diameter: 140mm
Lifting column wall thickness: 15mm
Double column spacing: 1360mm
Equipped with mechanical lock and hydraulic throttle plate



UE-L5800(A)

Double column underground lift

Maximum lifting height: 1850mm
Maximum lifting weight: 5000kg
Foundation depth: 2650mm
Lifting column diameter: 195mm
Lifting column wall thickness: 13mm
Double column spacing: 2350mm
Equipped with mechanical lock and hydraulic throttle plate

Truck Tire Changer



UE-589

Technical

Rim Diameter: 13" - 26" inch
 Rim width: 600 mm
 Max wheel diameter: 1400 mm
 Hydraulic System Working Pressure: 130 - 150 bar
 Hydraulic Station motor Power: 1.1kW/380V//50HZ/3Ph
 Main Shaft motor Power : 1.1kW /380V/ 50HZ/3PH
 Noise: ≤75dB
 Packing dimension: 1690x1140x1650mm
 Net Weight/Gross Weight: 510/739 kg
 Loading in 20/40 Ft. container: 7/14 sets

Highlights

1. Small size and light weight(520kg)makes the van can load more repair tools and tyres
2. The tool can retract back into(19 seconds) and extend out (23 seconds)of the van to make the effective of mounting and demounting of tyre same to the workshop.
3. Italian small chuck design, it can stop at any position, easy to mounting rim.
4. Equipped with emergency manual pump to ensure it can be pull back without power supply. It has dead lock device, all valves have different color. Whole emergency operation can be done by only one person.
5. Three position on bead breaker arm, convenient to choose suitable position.

*Truck tire changer has been specifically designed to mount and demount truck, bus, tractors and earthmoving vehicles tires Rim capacity 14"-56"
 Bi-directional chuck with 2 rotational speeds*



UE-0980

Technical Specification

Rim diameter	14"-56" with extensions
Max.wheel diameter	2500 mm
Max.wheel width	1200 mm
Max. tire weight	2000 kgs
hydraulic unit motor	4.0 KW
Power supply	380 V/400 V 50/60 Hz
N.W./G.W.	1145/1300 kgs
Package size	2310x2080x1100 mm
QTY/20'CY	4 PCS



Truck Tire Changer



Technical Specification

Rim diameter	14"-48" / 14"-60"
Max.wheel weight	2000 kgs
Max.wheel width	1400 mm
Max.tyre diameter	2600 mm
Hydraulic pump motor	4.0kw
Gearbox motor	4.0kw
Operation control voltage	24V
Overall dimensions approx	2500x2000 mm
Power	400V 50/60Hz 3P
N.W. / G.W.	1433 kgs / 1737 kgs
Package size	2310x2100x1100 mm
QTY/20'CY	4 PCS

◀ **UE-0998**



UE-0568 ◀



Semi-automatic truck tire changer
Universal self-centering chuck
Clockwise and anticlockwise rotation of chuck
Rim capacity 14"-26"

Technical Specification

Rim diameter	14"-26"
Max.wheel weight	500 kgs
Max.wheel width	780 mm
Max.tyre diameter	1600 mm
Hydraulic pump motor	1.5 kw 380 V/220 V
Bead breaker force	2500 kgs
Operation control voltage	24 V
Power	220 V/400 V 50/60 Hz
N.W./G.W.	570/647 kgs
Package size	2030x1600x1000 mm
QTY/20'CY	8 PCS

Car Tire Changer

UE-LC590D



Technical data

Rim Diameter	14" - 46" inch
Rim range with extension	40 - 56" inch
Rim width	1100 mm
Max wheel diameter	2200 mm
Hydraulic Power	130 - 150 bar
Hydraulic Station Motor Power	1.5kW 380V/3PH 50HZ
Main Shaft Motor Power	2.4kW/380V/50HZ/3P
Noise	< 75dB
Packing dimension	2280x2070x1070mm
Net Weight/Gross Weight	891/1152 kg
Loading in 20/40 Ft. container	4/10 sets

UE-LC588S



Technical data

Rim Diameter	14" - 26" inch
Rim width	1000 mm
Max wheel diameter	1600 mm
Hydraulic Power	130 - 150 bar
Hydraulic Station Motor Power	1.5KW 380V/3PH 50HZ
Main Shaft Motor Power	1.8KW 380V/3PH 50HZ
Noise	< 75dB
Packing dimensions	2100x1650x930 mm
Net weight	561kg
Gross weight	739 kg
Loading in 20/40 Ft. container	6/14 sets

UE-LC590C



Technical data

Rim Diameter	14" - 40" inch
Rim range with extension	40 - 56" inch
Rim width	1100 mm
Max wheel diameter	2200 mm
Hydraulic Power	130 - 150 bar
Hydraulic Station Motor Power	1.5kW 380V/3PH 50HZ
Main Shaft Motor Power	2.4/3.0kW/380V/50HZ/3P
Noise	< 75dB
Packing dimension	2280x2070x1070mm
Net Weight/Gross Weight	987/1252 kg
Loading in 20/40 Ft. container	4/10 sets

Car Tire Changer



UE-600

Semi-automatic side swing arm



Technical Specification

Motor power	0.75 kw/0.55 kw/1.1 kw
Power supply	220 V/400 V/110 V
Max.wheel diameter	41"(1040 mm)
Max.wheel width	14"(355 mm)
Outside clamping	10"-17"
Inside clamping	12"-20"
Air supply	8 bar
Bead breaker force	2500 kgs
N.W./G.W.	167/190 kgs
Package size	960x760x880 mm
QTY/20'CY	36 PCS

UE-8586

Outer Clamp: 10"-20"
 Inter Clamp: 12"-24"
 Max.Wheel Width: 450mm
 Max.Wheel Diameter: 1040mm
 Air Supply: 8- 10bar
 Motor Parameters: 220V 1.1KW/380V 0.75KW
 Gross Weight: 200Kg
 Net Weight : 170Kg
 Dimension: 1110mm x 900mmx 920mm



UE-326

Outer Clamp: 10"-20"
 Inter Clamp: 12"-24"
 Max.Wheel Width: 345mm
 Max.Wheel Diameter: 1040mm
 Air Supply: 8- 10bar
 Motor Parameters: 220V 1.1KW/380V 0.75KW
 Gross Weight: 320Kg
 Net Weight: 270Kg
 Dimension: 1180mmx 920mm x 1770mm



Car Tire Changer



UE-899C

Technical data

Rim range	1 0" -30" inch
Rim width	3" -13" inch
Max wheel diameter	1300 mm
Working pressure	8 -10 bar
Bead breaking force	1400 kg
Powers supply	11 OV /220V /380V
Motor Power	0.85kW/1.1kW
Rotation per minute	6 5/13rpm
Noise	<70dB
Machine dimensions	2460x7 370x7 755 mm
Packing dimensions	1680x7150x2000 mm
Net weight	584 kg
Gross weight	692kg
Loading in 40 Ft container	14 pcs



UE-896V

Technical data

Rim range	13" -30" inch
Rim width	3" -14" inch
Max wheel diameter	1200 mm
Working pressure	8 -10 bar
Bead breaking force	1000 kg
Powers supply	11 OV /220V /380V
Motor Power	0.8kW/1.1 kW
Rotation per minute	6.5/13rpm
Noise	<70dB
Machine dimensions	1670x2850x1950 mm
Packing dimensions	1550x1800x1870 mm
Net weight	510 kg
Gross weight	605 kg
Loading in 40 Ft container	8 sets



UE-889NV

Technical data

Outside Clamp	11" - 24" inch
Inside Clamp	13" - 26" inch
Rim width	3" - 14" inch
Max wheel diameter	1100 mm
Working pressure	8 - 10 bar
Bead breaking force	2800 kg
Powers supply	110V/220V/380V
Motor Power	0.75kW/1.1kW
Rotation per minute	6.5/13rpm
Noise	<70dB
Machine dimensions	1860×2260×2200 mm
Packing dimension	1350×1050×1800 mm
Net weight	285 kg
Gross weight	325 kg
Loading in 40 Ft. container	16 sets

Car Tire Changer



UE-GT895N

Technical data

Outside clamping range	13" - 24" inch
Inside clamping range	15" - 27" inch
Rim width	3" - 15" inch
Max wheel diameter	1180 mm
Working pressure	8 - 10 bar
Bead breaking force	2500 kg
Powers supply	110V/220V/380V
Motor Power	0.75kW/1.1kW
Rotation per minute	6.5/13rpm
Noise	<70dB
Machine dimensions	1950×2450×2200 mm
Packing dimensions	1440×1140×1830 mm
Net weight	500 kg
Gross weight	595 kg
Loading in 40 Ft. container	16 sets



UE-LC889N

Technical data

Outside clamping range	11" - 24" inch
Inside clamping range	13" - 26" inch
Rim width	3" - 14" inch
Max wheel diameter	1100 mm
Working pressure	8 - 10 bar
Bead breaking force	2800 kg
Powers supply	110V/220V/380V
Motor Power	0.75kW/1.1kW
Rotation per minute	6.5/13rpm
Noise	<70dB
Machine dimensions	1900×1350×2000 mm
Packing dimensions	1350×1100×1780 mm
Net weight	285 kg
Gross weight	325 kg
Loading in 40 Ft. container	48 sets



UE-885N

Technical data

Outside clamping range	10" - 20" inch
Inside clamping range	12" - 23" inch
Rim width	3" - 13" inch
Max wheel diameter	1120 mm
Working pressure	8 - 10 bar
Bead breaking force	2500 kg
Powers supply	110V/220V/380V
Motor Power	0.75kW/1.1kW
Rotation per minute	6.5/13rpm
Noise	<70dB
Machine dimensions	1900×1350×2050 mm
Packing dimensions	1130×910×1010 mm
Net weight	246 kg
Gross weight	285 kg
Loading in 40 Ft. container	52 sets

Car Tire Changer



UE-870L

Technical data

Outside clamping range	10" - 22" inch
Inside clamping range	12" - 25" inch
Rim width	3" - 14" inch
Max wheel diameter	1010 mm
Working pressure	8 - 10 bar
Bead breaking force	2500 kg
Powers supply	110V/220V/380V
Motor Power	0.85kW
Rotation per minute	6.5rpm
Noise	<70dB
Machine dimensions	1200×1350×1890 mm
Packing dimensions	1440×1140×1830 mm
Net weight	225 kg
Gross weight	265 kg
Loading in 40 Ft. container	48 sets



UE-890N

Technical data

Outside clamping range	11" - 24" inch
Inside clamping range	13" - 26" inch
Rim width	3" - 13" inch
Max wheel diameter	1250 mm
Working pressure	8 - 10 bar
Bead breaking force	2500 kg
Powers supply	110V/220V/380V
Motor Power	0.85kW
Rotation per minute	6.5rpm
Noise	≤70dB
Machine dimensions	1350×1300×1950 mm
Packing dimensions	1150×920×1050 mm
Net weight	239 kg
Gross weight	269 kg
Loading in 40 Ft. container	48 sets



UE-810

Technical data

Outside clamping range	10" - 18" inch
Inside clamping range	12" - 21" inch
Rim width	3" - 12" inch
Max wheel diameter	960 mm
Working pressure	8 - 10 bar
Bead breaking force	2500 kg
Powers supply	110V/220V/380V
Motor Power	0.85kW
Rotation per minute	6.5rpm
Noise	<70dB
Machine dimensions	1400×1200×1900 mm
Packing dimensions	980×760×950 mm
Net weight	179 kg
Gross weight	207 kg
Loading in 40 Ft. container	72 sets

Car Tire Balancer



UE-CB46

Technical data

Rim diameter	1" - 28" inch
Max wheel weight	200 kg
Max wheel diameter	1200mm
Rim width	2" - 20" inch
Precision	±1g (car) / ±10g (truck)
Motor Power	0.37kW
Power supply	100/230V 1ph
Rotation per minute	80rpm / 120rpm
Balancing time	9s (car) / 20s (truck)
Second time mounting test	≤5g
Machine dimensions	1600x1100x1480 mm
Packing dimension	1700x1100x1240 mm
Net weight	285 kg
Gross weight	318 kg
Loading in 40 Ft. container	14 sets



UE-CB66

Technical data

Rim diameter	1" - 28" inch
Max wheel weight	70 kg
Max wheel diameter	1118 mm
Rim width	1,5" - 20" inch
Precision	±1g
Motor Power	90W
Power supply	100/230V 1ph
Rotation per minute	140rpm
Balancing time	7s
Second time mounting test	≤5g
Machine dimensions	1550x1160x1243 mm
Packing dimension	990x760x1150 mm
Net weight	128 kg
Gross weight	166 kg
Loading in 40 Ft. container	72sets

Motorcycle Wheel Balancer



UE-108

Technical Specification

Max. wheel weight	65 kgs
Power supply	220 v/110 v
Balancing accuracy	±1 g
Balancing speed	80 r.p.m
Rim diameter	10"-24"
Rim width	1.5"-20"
Measuring time	8 sec.
Noise level	<70 dB
Package size	1# 760x560x1030 mm
	2# 730X350X160 mm
N.W./G.W.	1# 46/66 kgs
	2# 4.9/5.9 kgs
QTY/20'CY	60 PCS

Car Tire Balancer



UE-CB67

Technical data

Rim diameter	1" - 28" inch
Max wheel weight	70 kg
Max wheel diameter	1118 mm
Rim width	1,5" - 20" inch
Precision	±1g
Motor Power	90W
Power supply	100/230V 1ph
Rotation per minute	140rpm
Balancing time	7s
Second time mounting test	≤5g
Machine dimensions	1550x1160x1240 mm
Packing dimension	990x760x1150 mm
Net weight	128 kg
Gross weight	166 kg
Loading in 40 Ft. container	72sets



UE-CB68

Technical data

Rim diameter	1" - 28" inch
Max wheel weight	70 kg
Max wheel diameter	1118 mm
Rim width	1,5" - 20" inch
Precision	±1g
Motor Power	90W
Power supply	100/230V 1ph
Rotation per minute	140rpm
Balancing time	7s
Second time mounting test	≤5g
Machine dimensions	1550x1160x1243 mm
Packing dimension	1070x760x1150 mm
Net weight	132 kg
Gross weight	170 kg
Loading in 40 Ft. container	66sets



UE-CB75

Technical data

Rim diameter	1" - 28" inch
Max wheel weight	70 kg
Max wheel diameter	1118 mm
Rim width	1,5" - 20" inch
Precision	±1g
Motor Power	90W
Power supply	100/230V 1ph
Rotation per minute	140rpm
Balancing time	7s
Second time mounting test	≤5g
Packing dimension	990x760x1160 mm
Net weight	130 kg
Gross weight	168 kg
Loading in 40 Ft. container	72sets

Car Tire Balancer

UE-CB76



Technical data

Rim diameter	1" - 28" inch
Max wheel weight	70 kg
Max wheel diameter	1118 mm
Rim width	1,5" - 20" inch
Precision	±1g
Motor Power	90W
Power supply	100/230V 1ph
Rotation per minute	140rpm
Balancing time	7s
Second time mounting test	≤5g
Machine dimensions	1390x980x1470 mm
Packing dimension	1170x880x1170 mm
Net weight	149 kg
Gross weight	187 kg
Loading in 40 Ft. container	52sets

UE-CB78P



Technical data

Rim diameter	1" - 28" inch
Max wheel weight	70 kg
Max wheel diameter	1118 mm
Rim width	1,5" - 20" inch
Precision	±1g
Motor Power	370W
Power supply	100/230V 1ph
Rotation per minute	140rpm
Balancing time	7s
Second time mounting test	≤5g
Machine dimensions	1390x980x1470 mm
Packing dimension	1400x880x1170 mm
Net weight	154 kg
Gross weight	192 kg
Loading in 40 Ft. container	52sets

UE-CB460B



Technical data

Rim diameter	10" - 24" inch
Max wheel weight	200 kg
Max wheel diameter	1200mm
Rim width	1,5" - 20" inch
Precision	±1g (car)/±10g (truck)
Motor Power	0.55kW
Power supply	100/230V 1ph
Rotation per minute	100rpm (car)/200rpm (truck)
Balancing time	9s (car) / 20s (truck)
Second time mounting test	≤5g
Machine dimensions	1330x1280x1320 mm
Packing dimension	1300x990x1150 mm
Net weight	220 kg
Gross weight	270 kg
Loading in 40 Ft. container	42 sets

Car Tire Balancer



UE-CB910GB

Technical data

Rim diameter	10" - 24" inch
Max wheel weight	65 kg
Max wheel diameter	1000mm
Rim width	1,5" - 20" inch
Precision	±1g
Motor Power	0.25kW
Power supply	100/230V 1ph
Rotation per minute	200rpm
Balancing time	10s
Second time mounting test	≤5g
Machine dimensions	1250x1050x1050 mm
Packing dimension	930x710x1160 mm
Net weight	107 kg
Gross weight	137 kg
Loading in 40 Ft. container	68 sets



UE-CB953LB

Technical data

Rim diameter	10" - 24" inch
Max wheel weight	70 kg
Max wheel diameter	1000mm
Rim width	1,5" - 20" inch
Precision	±1g
Motor Power	0.25kW
Power supply	100/230V 1ph
Rotation per minute	200rpm
Balancing time	10s
Second time mounting test	≤5g
Machine dimensions	1320x1050x1460 mm
Packing dimension	1100x710x1160 mm
Net weight	118 kg
Gross weight	147 kg
Loading in 40 Ft. container	68 sets



UE-650

Technical data

Max.wheel weight:	65Kg
Rim diameter:	13"-24"
Rim width:	1.5"-16"
Motor Parameters:	220V/0.25KW
Balancing accuracy:	±1g
Measuring time:	6-8s
Noise level:	≤70dB
Gross weight:	110Kg
Net Weight :	90Kg
Dimension:	1000mmx 680mm x 1060mm

Tire Balancer



UE-1200

Technical Specification

Max. wheel weight:	150 kg
Rim diameter	13"-24"
Rim width	5.5"-20"
Max. Wheel Diameter.	1200 mm
Testing time	8 s
Air pressure	6-8 bar
Power supply	220 V/400 V
N.W./G.W.	250/320 kgs
Package size	1250x960x1100 mm
QTY/20'CY	20 PCS

*.Movable & easy- your good helper.
.With self-calibration and
self-diagnosis functions.
.LED light & Digital display.*

CE UE-110

Technical Specification

Optional power supply	110v(1ph)/220v(1/3ph) 380v(3ph)
Balancing speed	±120 r.p.m
Balancing accuracy	± 1g(0.04 OZ)
Measuring time	8s
N/G weight	35/42 kg(77.2/92.6 lbs)



UE-8601

Max.wheel weight: 65Kg
Rim diameter: 13"-24"
Rim width: 1.5"-16"
Motor Parameters: 220V/0.25KW
Balancing accuracy: ±1g
Measuring time: 6-8s
Noise level: ≤70dB
Gross weight: 100Kg
Net Weight: 80Kg
Dimension: 960mmx 790mm x 1140mm

3D four wheel alignment



UE-421

1. Has independent intellectual property rights
 2. 3-D special high-definition camera
 3. high-definition wide- -angle lens
 4. invisible laser target plate
 5. LED optical indicator system
 6. fast retrieval
 7. dynamic measurement
 8. fast measurement
 9. extreme speed response
 10. frame data measurement
 11. chassis parameter measurement
 12. customer file management
 13. ready-to-use
 14. software data correction function
 15. short di stance Installation
 16. tailor-made special funct ions required.
- Beam wooden box: 2770X270X320
 Accessory wooden box: 1400X820X820
 Total volume: 1.1 8m³
 Total weight: 110kgs

Integral Main Pillar	1pic	CabinetCamera Beam Assembly	1pic
3D Customi zed Computer	1pic	32- inch LCD TV	1pic
19 inch LED display	1pic	Laser target	4pic
12-22 inch clamb	4pic	Deluxe turntable	2pic
Steering wheel holder	1pic	Foot brake fixator	1pic
Wedge block	1pic	Encrypted Dog	1pic
System Software Disk	1pic	Manual Warranty Card	1pic

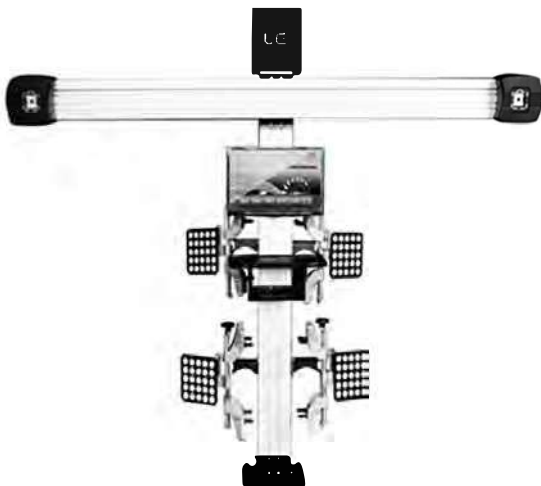

UE-420

- 1.Independent research and development abilit, software upgrade continuous (software function, interface design and database upgrade).
 - 2.Imported camera lens with high quality.
 - 3.Non-contact, avoid damage to Aluminum rim.
 - 4.Voice Prompt Function makes the operation convenient.
 - 5.Intellectual property is one of our development value and will realize max. profit.
 - 6.All the components are made from moulds, can be installed or replaced at will.
 - 7.The software function and interface can be designed at customers' demand.
 - 8.The promoter elements under warranty for life, low-price in using.
 - 9.HD target board can realize interaction without calibration.
 - 10.With vehicle and customer search function, quick and convenient in searching.
 - 11.Pure homemade 3D four wheel algnment tester, high Precision in measurement.
- There are two items in total, one is 40kg, the size is 2770*270*320mm, the other is 100kg, the accessory box is 730*730*810mm

ITEMS	PRECISION	MEASURING RANGE
FRONT WHEEL CAMBER	±0.02degree	±10degree
CASTER ANGLE	±0.05degree	±10degree
FRONT WHEEL LEANING	±0.05degree	±20degree
FRONT WHEEL TOE-IN ANGLE	±0.02degree	±20degree
REAR CAMBER	±0.02degree	±10degree
REAR WHEEL TOE ANGLE	±0.02degree	±20degree
REAR THRUST ANGLE	±0.02degree	±5degree
WHEEL DIFFERENCE	±2.5mm	3000mm
WHEEL BASE DIFFERENCE	±2.5mm	3000mm

Four Wheel Alignment



UE-A730G

Technical data

Front axle	ACCURACY	MEASURING RANGE	TOTAL MEASURING RANGE
Total toe	±3'	±4°	±48°
Total toe	±6'	±4+48°	±48°
Partial toe	±1.5'	±2°	±24°
Partial toe	±3'	±4+24°	±24°
Set-back	±5'	±3°	±3°
Camber	±5'	±3°	±10°
Camber	±7'	±3+10°	±10°
Caster	±10'	±24°	±24°
King-pin	±10'	±24°	±24°
Rear axle			
Total toe	±3'	±4°	±48°
Total toe	±6'	±4+48°	±48°
Partial toe	±1.5'	±2°	±24°
Partial toe	±3'	±4+24°	±24°
Set-back	±5'	±3°	±3°
Camber	±5'	±3°	±10°
Camber	±7'	±3+10°	±10°
Thrust angle	±2'	±3°	±24°



UE-101

View field of camera cross beam fixed type

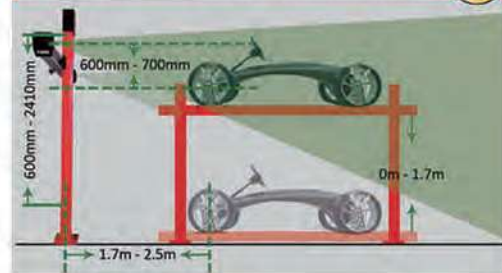

Product details



camera



camera cross beam fixed on the stand column, can't real time move up and down.



Steel stand column



Simple cabinet is assembled on the stand column

Four Wheel Alignment

Product details



1.3Mps camera



Camera cross beam manually lifting structure



Camera cross beam trace targets manually



Aluminium stand column



Simple cabinet is assembled on the stand column

UE-111



UE-161



Product details



1.3Mps camera



Electric control lifting structure



Camera cross beam's up-down button



Steel stand column



Smaller cabinet is assembled on the stand column

Four Wheel Alignment



Product details



5Mps camera



Camera cross beam automatically lifting structure



Camera cross beam trace targets automatically structure



LCD screen operation indications and adjustment values can be displayed directly



Mini targets



UE-165

View field of camera cross beam fixed type

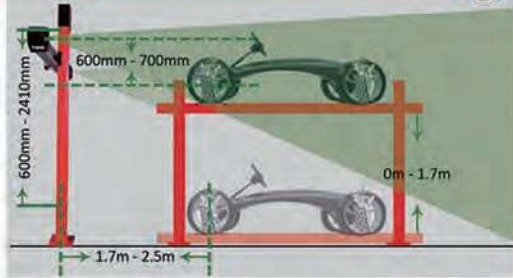

Product details



5Mps camera



Electric control lifting structure



Mini targets



Camera cross beam's up-down button



Steel stand column



Movable cabinet with installed stand column

UE-325



Product details



1.3Mps camera



Three cameras structure



No camera cross beam structure

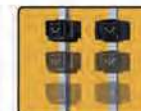

Automatically lifting by motor control

Four Wheel Alignment

UE-800



Product details



measurement head



LCD screen



ZIGBEE wireless communication



Cable/charging port



Toe CCD box



Axle CCD box

UE-900



Product details

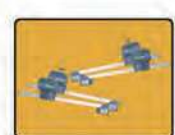

measurement head



LCD screen



ZIGBEE wireless communication



Cable/charging port



Toe CCD box



Axle CCD box

Paint spray room

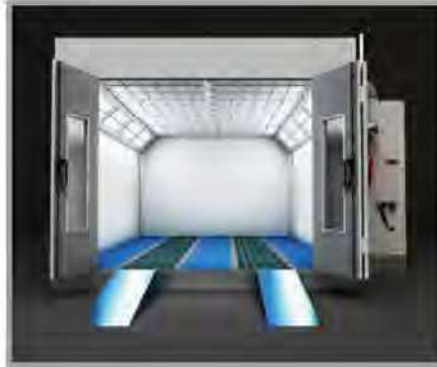

Model: UE-100 Spray booth specification

Outside Dimension (mm)	7000×5900×3400	Inside Dimension(mm)	6900×3900×2650
Front Door(mm)	3000×2600(W*H)	Service door(mm)	800×2000(W*H)
Total Power	7kw		
Cabin system	Front door	3 folded sheet metal door	
	Wall panel	50mm EPS sandwich panel, steel sheet thickness: 0.426mm	
	Ceiling panel	Galvanized steel sheet	
	Basement	30mm depth construction galvanized basement, two rows galvanized grids and three rows checkered plates.	
	Ramps	Two pieces 2000*520mm ramps	
	Door glass	5mm tempered glass	
Air make-up system	Air inlet fan system	2 sets 3 KW centrifugal fan, fan model: YDW-4.5AL.	
	Exhausted fan system	For option	
	Air inlet capacity	21000m ³ /h	
	Exhausted ducting	Four meters straight galvanized ducting and one 135 degrees elbow	
Purification system	Pre-filter	G3 grade	
	Ceiling filter	600G filter EU5 / F5	
	Floor filter	Fiberglass filter	
	Exhausted filter	Fiber glass and carbon filter	
Heating system	Heat Exchanger	SUS 304 stainless heating exchanger	
	Heating burner	Riello diesel oil burner (gas burner for option)	
	Heating productivity	20000Kcal/hour	
	Spray to baking switch	Pneumatic damper	
	Chimney ducting	4 meters chimney and one chimney elbow	
	heating temperature	Maximum 80℃	
	fuel consumption	6-8L/vehicle	
Lighting system	Ceiling lighting	8 Units, each 4 * 24W LED lamps.	
	Side lighting	For option	
	Illumination	900LUX	
Control system	Switch controlling system	Spraying & baking switch, lighting switch, temperature controlling switch, emergency stop, breakdown alarm, failure alarm, pressure gauge	

Paint spray room



UE-220 Electrical Infrared heating system

Outside Dimension (mm)	7000×5900×3400	Inside Dimension(mm)	6900×3900×2800
Front Door(mm)	3000×2600(W*H)	Service door(mm)	800×2000(W*H)
Total Power	37kw		
Cabin system	Front door	3 folded sheet metal door	
	Wall panel	50mm EPS sandwich panel, steel sheet thickness: 0.426mm	
	Ceiling panel	Galvanized steel sheet	
	Basement	30mm depth construction galvanized basement, two rows galvanized grids and three rows checkered plates.	
	Ramps	Two pieces 2000*520mm ramps	
	Door glass	5mm tempered glass	
Air make-up system	Air inlet fan system	2 sets 3 KW centrifugal fan, fan model: YDW-4.5AL.	
	Exhausted fan system	For option	
	Air inlet capacity	21000m ³ /h	
	Exhausted ducting	Four meters straight galvanized ducting and one 135 degrees elbow	
Purification system	Pre-filter	G3 grade	
	Ceiling filter	600G filter EU5 / F5	
	Floor filter	Fiberglass filter	
	Exhausted filter	Fiberglass filter	
Heating system	Heating lamps	10 Units Infrared heating box, each box with 3X1000W lamps	
	Power	30kw	
	Max temperature	80℃	
Lighting system	Ceiling lighting	8 Units, each 4 * 24W LED lamps.	
	Side lighting	For option	
	Illumination	900LUX	
Control system	Switch controlling system	Spraying & baking switch, lighting switch, temperature controlling switch, emergency stop, breakdown alarm, failure alarm, pressure gauge	

Movable preparation room



UE-400

Air enters the cabin through filtered plenum, and is exhausted outside.
The roof is with filter holder and light. It can do easy base painting. (Baking function as option)

External size(m): 3.7x7.1x3.2
Power (kw): 7

Internal size(m): 3.48x6.0x2.7
Remark: Heating Device as option



Air enters the cabin through filtered plenum,
and then exhausted outside.

Power (kw): 5.5
Cabinet: 3.48(W)*1.06(L)

Girder lift correction instrument



UE-300

Product information

UE-300, small size bench welded made of cold high-alloy rectangular tubes is designed professionally for body collision quick repair by choosing better material, improving welding technique and enhancing stress intensity to make the repairing work more precise and faster. In accordance with European advanced technology, simple, practical, safe and precise for fast repair.

Main technical parameter

Length	3320MM
Width	880MM
Height	110-1700MM
Pulling capacity	60KN
Rated voltage	220V/380V
Radius of pulling	360°
Max. loading Capacity	3000KG



UE-388E

Product information

UE-U388E,full automatic computerized working platform made of fate plate and square holes steels is designed professionally for body collision repair by choosing better material,improving welding technique and enhancing stress intensity to make the repairing work more precise and faster.one of important features is no-blind working range,which is in accord with the technician's habit to make more convenient operation . it can be widely used for nearly all kinds of imported cars,commercial vehicles and suvs collision repair.

Main technical parameter

Length	5600MM
Width	2260MM
Height	0-380-1080MM
Pulling capacity	95KN
Rated voltage	220V/380V
Radius of pulling	360°
Max. loading Capacity	4000KG

Girder lift correction instrument

Product information

UE-600, European style working bench made of cold high-alloy rectangular tubes is designed professionally for body collision repair by choosing better material, improving welding technique and enhancing stress intensity to make the repairing work more precise and faster. In accordance with European advanced technology, simple, practical, safe and precise for complete collision repair.

Main technical parameter

Length	4160MM
Width	950MM
Height	260-1600MM
Pulling capacity	95KN
Rated voltage	220V/380V
Radius of pulling	360°
Max. load	3000KG



UE-600



UE-1000

Product information

UE-1000, Bench rack style working bench made of cold high-alloy rectangular tubes is designed professionally for body collision repair by choosing better material, improving welding technique and enhancing stress intensity to make the repairing work more precise and faster. In accordance with European advanced technology, simple, practical, safe and precise for complete collision repair.

Main technical parameter

Length	5000/5500MM
Width	1170MM
Height	400-1190MM
Pulling capacity	100KN
Rated voltage	220V/380V
Radius of pulling	360°
Max. load	4000/4200KG

Girder lift correction instrument

UE-L155



Floor System

According to specification requirements and various operating requirements of auto body collision repair equipment, after balancing overall the performance and price of equipments as well as the use habits of metal plate technicians, we sincerely recommend to you--UE-L155



Features:

Flexible pulling tower, standing on the ground stably by three points, 10T hydraulic cylinder working horizontally, without any wasting of component forces. Strong pulling power can draw and repair the auto body between two points meanwhile



The small flexible pulling tower can fix the car as well as repairing assembled with the hydraulic equipments and fixed devices.



Platform track makes the car driven on and off more convenient. It can adjust the length and width to the maximum range. Be Suitable for various models of cars, more precise and faster for auto body collision repair.



UE-L199



Product information

UE-L199, working platform made of rectangular tube steels is designed professionally for body collision repair by choosing better material, improving welding technique and enhancing stress intensity to make the repairing work more precise and faster. One of important features is no-blind working range, which is in accord with the technician's habit to make more convenient operation. It can be widely used for nearly all kinds of imported cars, commercial vehicles and SUVs collision repair.

Main technical parameter	UE-L188	UE-L199L
Length	5200MM	5600MM
Width	2140MM	2140MM
Height	520MM	520MM
Pulling capacity	95KN	95KN
Air supply required	0.8MPA	0.8MPA
Radius of pulling	360°	360°
Max. load	3500KG	3500KG

Diagnostic Tool



UE-320

Product Parameters

- Display: black&white color display (320 ×240 dpi)
- Operating Temperature: 0 to 60°C (32 to 140 F°)
- Storage Temperature: -20 to 70°C (-4 to 158 F°)
- External Power: 8.0 to 18.0 V power provided via vehicle battery

UE-330

Product Parameters

- Display: black&white color display (320 ×240 dpi)
- Operating Temperature: 0 to 60°C (32 to 140 F°)
- Storage Temperature: -20 to 70°C (-4 to 158 F°)
- External Power: 8.0 to 18.0 V power provided via vehicle battery
- Length\Width\Height: 123 mm (4.85")\73.35 mm (2.90")\21.8 mm (0.85")



1st Step : Connect the battery clip to the car battery
 Red clip connects car battery positive
 Black clip to connect car battery negative
 Note: When the circuit is reversed, the society will sound an alarm.

2nd step : Wait for the device to get ready
 Connecting the battery → jump starter be turned on → Loading (within 3-5 minutes) → Full Charge → Next Step

3rd Step : Start Vehicle engine
Operation for 1 person:
 Press the red Start Delay button, start car engine after the device counts down 10 seconds and gives alert sounds.
Operation for 2 persons:
 One person press the green Start button, the other person starts engine in the car.

UE-335

Product Parameters

- Suitable vehicle mode: Gasoline vehicles≤5.0L
- Output current: 12V/DC 200A
- Package size: 270* 180*85(mm)
- Product size: 220* 120* 55(mm)
- Input current: DC charging voltage 5~12V, current 5A
- Preparing time: 3~ 8 minutes
- Starting current: 400A
- Peak current: 1000A
- Working temperature: -40°C~ 80°C



Diagnostic Tool



UE-360

Product Parameters

System voltage: 12 Volts

Input voltage range: 9V~15V

Power: 8W

AH range: 30-220AH

Testing range: 100 ~ 2000 CCA,

100 ~ 1200 DIN, 100 ~ 1200 IEC, 100 ~ 1700 EN



UE-460

Product Parameters

Type: 12V 24V Battery Tester

Package dimensions: 200x120x60mm

Package weight: 400g

Operating temperature: -20~80 (°C)



UE-520

Product Parameters

Voltage: 12V

Packing size (LWH): 280x175x50mm

weight: 520g

Operating temperature: -10-60 (°C)



Diagnostic Tool



UE-660

Product Parameters

Voltage: 12V/24V
 Power: 8W
 Package dimensions: 260x160x80mm
 Package weight: 650g
 Working Environment Temp: -10°C-50°C



UE-BOX

Product Parameters

Voltage: 12V
 Packing size (LWH): 200x120x60mm
 weight: 400g
 Support system: Android system and IOS system
 Power: 8W



Welding machine



UE-508

Product Parameters

Voltage: 110V or 240V, 220V
 Length: 45cm
 Width: 21cm
 Height: 33cm
 Weight: 5.7kg



Walnut sand cleaning machine



UE-668

Product Parameters

Voltage: 220V

Packing size (LWH): 510x520x900mm

weight: 40KG

Diagnostic Tool



UE-X50PRO

Product Parameters

Operating voltage: 10-18V DC

Packing size (LWH): 105x85x100mm

weight: 200g

Operating current: <80mA

Sleep current: <1mA

Working temperature: -20~75°C



UE-X50PLUS

Product Parameters

Operating voltage: 10-18V DC

Packing size (LWH): 95x95x80mm

weight: 180g

Operating current: <80mA

Sleep current: <15mA

Operating temperature: -20~85 °C



Digital Projector



UE-X60

Product Parameters

Operating voltage: 10-18V DC
 Operating current: <80mA
 Sleep current: <15mA
 Operating temperature: -20 - 75°C
 Dimensions: 60mm X 50mm X 67mm
 Hardware: CPU based on 32 bit ARM CORTEX-M3 kernel
 Maximum operating frequency: 72MHz



Car display

UE-X70GPS

Product Parameters

Main Material: EP ABS+PC
 Rated Voltage: DC12V / DC5V
 Type: UE-X70 GPS
 Rated Power: 3W
 Dimension: 80.5*74.5*76.5(mm)
 Work Temperature: -10°C ~ 55°C
 Quality: First Grade
 Suitable Vehicle Model: All Types



Car display Diagnostic



UE-X80

Product Parameters

Work Temp: 3~60°C
 Size (LWH): 87* 77*51 (mm)
 External Power: 8~18V Vehicle Battery
 Working current: <80mA
 Type: Engine Analyzer



Auto Slope Meter



UE-X90

Product Parameters

Power: DC 10V ~30V
 Depression&Elevation angle: -40~ +40°
 Clock Error Value: <1 minute
 Speed Accuracy: < 0.36Km/h
 GPS Cold Boot Time: 32s (average)
 Wireless Transmission Frequency: 2.4GHz
 Product Size: 70*59*59(mm)
 Weight: 203g

Car Display

Equipped with light sensing device, the day and night display is still clear.



UE-X100S

Product Parameters

Memory: 32K
 Screen: 4.3 inch composite display
 Size: 135X105X45MM
 Working temperature: -10°C~55°C
 Package dimensions: 160x150x55mm
 Package weight: 380g

Smoke Leak Detector



UE-106

Product Parameters

power supply: DC12V, vehicle battery

Smoke output value: 6l/min

Length: 15cm

width: 10cm

height: 5cm

Weight: 3.5kg

Material: high quality metal and plastic

Power: 8W

UE-202

Product Parameters

Dimension of host: 210x135x110mm

Package weight: 4.5kg

Package size: 27x220x255mm

Output pressure: 10-13 psi

Output flow: 10-15L /min

Air supply mode: Built-in air pump

Power supply: 12V vehicle battery

Fluid capacity: 30ml



UE-206

Product Parameters

Dimension of host: 270x150x150mm

Package weight: 5kg

Package size: 300x235x320mm

Output pressure: 10-18 psi

Output flow: 10-20L/min

Air supply mode: Built-in air pump

Power supply: 12V vehicle battery

Fluid capacity: 40ml



fuel injector tester

UE-150

Product Parameters

Power supply: AC220V±10%

Frequency: 50HZ±0.5

Humidity: <85%

Environment Temperature: 0°C~+40°C

Magnetic Field: <400A/m



UE-200

Product Parameters

Type: Car Washer, Auto fuel injector cleaner & tester

Power of Ultrasonic: 70W

Voltage: 110V/220V

Fuel Tank Capacity: 2000 ml

Speed Range: 0~7500 rpm

System Pressure: 0~0.6Mpa (adjustable)

Gross Weight: 18Kg

Size: 60cm x 40 cm x 20 cm

Auto Welder



UE-308

Product Parameters

Power supply: AC110V±10%

Frequency: 50/60Hz

Phase: 1PH Rated

input(KVA): 6.0 Open circuit voltage(V)

56 Amperage range(A): 50-160 Rated

Duty cycle (%): 60 Rated working

voltage(V): 16.5-24.4

Weight(kg): 4.2

Dimension(L x W x H)(MM): 290*133*295

Power charging starter



UE-325

Product Parameters

Input rated voltage: 220 V±15%

Input frequency: 50 Hz - 60Hz

Rated input power: 5.6KVA

Welding current: 20A - 140A

Welding voltage: 21 V-25.6 V

Charging current: 30 A

Charging voltage: 12 V

Starting current: 400 A

Starting voltage: 12V

rate output: 140A25.6V

rate output: 83 A 23.3 V

Charging no-load voltage: 15 V

Starting no-load voltage: 15 V

Welding no-load voltage: 56 V

No-load loss: 30 W

Effectiveness (%): 85%

Power factor: 0.73

Package weight: 9kg/ 19.8lb

Net Weight: 6.9kg/ 15.2lb

Dimensions: 46.5*33*26.5cm

Car diagnostic instrument



UE-GT90

Product Parameters

Screen: 12.2" diagonal, 1280* 800 pixel. Dust-proof, Water-proof and Drop-proof Touch Screen; daylight readable color LCD screen
 Touch with Gloves: Supported
 Operating System: Windows 10 Pro
 Processor: Intel@Celeron@Processor N3060, 2M Cache, upto 2.48 GHz
 Memory: 2GB DDR3L (1333MHz)
 SSD Hard drive: 32GB/64G/128G/256G
 HDMI: Yes
 Compass: Yes
 Camera: 5 megapixels rear-facing
 External Power: 8-18 Volt powered by vehicle battery
 Battery: 8000mAh, lithium-polymer battery. Chargeable via 19V AC/DC power supply
 Dimensions: 320* 260* 25mm
 Weight: 1.4kg (main unit)

UE-i70pro

Product Parameters

Screen: 8" diagonal, daylight readable color LCD screen; 1280*800 pixel
 Touch With Gloves: Supported
 Operating System: Android system
 Processor: MT 8163 (ARM Cortex, A53 x 4, 1. 3GH z)
 Memory: 2GB DDR3L
 Hard Drive: 32GB
 HDMI: YES
 Camera: 5 megapixels rear-facing
 Battery: 8000mAh, lithium-polymer battery. Chargeable via 5V AC/DC power supply
 Dimensions: 230*155*21mm



UE-i70

Product Parameters

Screen: 7" diagonal, daylight readable color LCD screen; 1024*600 pixel
 Touch With Gloves: Supported
 Operating System: Android system
 Processor: MT 8163 (ARM Cortex, A53 x 4, 1. 3GH z)
 Memory: 1GB DDR3L
 Hard Drive: 32GB
 Communication Interface: Built-in WIFI 802.11 b/g Wireless LAN micro USB 2.0 OTG, USB 2.0 HOST standard Bluetooth 4.0 (10-20 m)
 Camera: 5 megapixels rear-facing
 Battery: 4000mAh, lithium-polymer battery. Chargeable via 5V AC/DC power supply
 Dimensions: 205*135*30mm

Car diagnostic instrument



UE-680pro

Product Parameters

Display: 4.3" TFT color display
 Working Temp: 0 to 60°C (32 to 140°F)
 Storage Temp: -20to 70°C(-4 to 158°F)
 External Power: 8-18 Volts powered by vehicle battery
 Dimensions: 200* 130* 40mm (L*W*H)
 Blow Molding Case: 330* 220* 80mm (L*W*H)
 Weight: 1.8KG
 QTY/CTN: 20SETS
 Weight/CTN: 38KG

UE-NT680

Product Parameters

Display: 4.3" TFT color display
 Working Temp: 0 to 60°C (32 to 140°F)
 Storage Temp: -20to 70°C(-4 to 158°F)
 External Power: 8-18 Volts powered by vehicle battery
 Dimensions: 200* 130* 40mm (L*W*H)
 Blow Molding Case: 330* 220* 80mm (L*W*H)
 Weight: 1.8KG
 QTY/CTN: 20SETS
 Weight/CTN: 38KG



UE-680LITE

Product Parameters

Display: 4.3" TFT color display
 Working Temp: 0 to 60°C (32 to 140°F)
 Storage Temp: -20to 70°C(-4 to 158°F)
 External Power: 8-18 Volts powered by vehicle battery
 Dimensions: 200* 130* 40mm (L*W*H)
 Blow Molding Case: 330* 220* 80mm (L*W*H)
 Weight: 1.8KG
 QTY/CTN: 20SETS
 Weight/CTN: 38KG

Car decoder



UE-NT630

Product Parameters

Display: 2.8" TFT color screen
 Operating Temp: 0 to 60°C (32 to 140°F)
 Storage Temp: (-20 to 70°C) (-4 to 158°F)
 Power: 8 to 18 V provided via vehicle
 Dimensions: 194*94*32mm (L*W*H)
 Weight: 0.9KG
 QTY/CTN: 30SETS
 Net Weight/CTN: 28KGS
 CTN MEAS: 456*442*515mm



UE-NT401

Product Parameters

Display: 2.8" TFT color screen
 Operating Temp: 0 to 60°C (32 to 140°F)
 Storage Temp: -20 to 70°C (-4 to 158°F)
 Power: 8 to 18 V provided via vehicle
 Dimensions: 145 * 94 * 32MM
 Weight: 0.6KG
 Dimensions of Packaging: 265*175*42MM
 Dimensions of Carton: 530*525*336MM
 PCS/CTN: 48PCS
 Net Weight/CTN: 28.8KGS
 Gross Weight/CTN: 30KGS



UE-NT304

Product Parameters

Display: 2.4" TFT color screen
 Working Temp: 0 to 60°C (32 to 140°F)
 Storage Temp: -20 to 70°C (-4 to 158°F)
 Power: 8-18 Volts powered by vehicle battery
 Dimensions: 120mm*75mm*20mm
 Weight: 0.3kg
 QTY/CTN: 60SETS
 Weight/CTN: 21.5KG
 CTN MEAS: 530*525*336mm



Car decoder



UE-NT220E

Product Parameters

Display: Backlit 128 x 64 pixel LCD
 Working Temp: 0 to 60°C (32 to 140°F)
 Storage Temp: -20 to 70°C (-4 to 158°F)
 Power: 8-18 Volts powered by vehicle battery
 Dimensions: 103mm(4.0")* 75mm(2.96")* 20mm(0.78")
 Weight: 325g
 QTY/CTN: 50SETS
 Weight/CTN: 19.5KG
 CTN MEAS: 465*440*400mm



Car diagnostic instrument

UE-T100

Product Parameters

Display: Backlit, 128*64 pixel display with contrast adjustment
 Operating Temperature: 0 to 60°C (32 to 140°F)
 Storage Temperature: -20 to 70°C (-4 to 158°F)
 Power: 3.7V Li-polymer battery
 Radio Reception: 315 MHz and 433.92 MHz
 Dimensions: 200*100*38mm (L*W*H)
 Weight: 0.4KG



UE-BT780

Product Parameters

Voltage measuring: 6V to 32V
 Battery type: Flooded, AGM, GEL, start-stop
 AGM & EFB batteries
 Battery rating: 100-2000 CCA
 Standard support: CCA, BCI, CA, MCA, JIS,
 DIN, IEC, EN, SEA, GB
 Weight: 0.8KG
 Dimension: 90*240*45 MM



Car diagnostic instrument



UE-BT705

Product Parameters

Voltage measuring: 6V to 32V
 Battery type: Flooded, AGM, GEL
 Battery rating: 100-2000 CCA
 Standard support: CCA, BCI, CA, MCA, JIS, DIN, IEC, EN, SEA
 Weight: 1.6KG
 PC/CTN: 30SETS
 Gross Weight/CTN: 38KG



UE-OS100

Product Parameters

Bandwidth: 70MHz
 Channel: 4
 Real-time Sampling Rate: 1GSa/s
 Memory Depth: 64K
 Time Base Precision: ± 50 ppm
 Time Base Range: 2ns/div-1000s/div
 (1-2-4 sequences)
 Input Impedance: 1MQ 25pF
 Input Sensitivity: 2mV/div- 10V/div
 Vertical Resolution: 8Bit
 DC Gain Accuracy: $\pm 3\%$
 Bandwidth: 20MHz
 Trigger Mode: Edge, Pulse, Video, Alternative
 Volume: 175mm * 105mm * 25mm
 Weight: 0.9KG
 Accessory: 2 passive probes, 2 gator clip lines



Car battery analyzer



UE-BT100

Product Parameters

Voltage measuring: 6V to 18V
 Battery type: Flooded, AGM, GEL
 Battery rating: 100- 1100 CCA
 Standard support: CCA, BCI, CA, MCA, JIS, DIN, IEC, EN, SEA
 Weight: 0.32KG
 PC/CTN: 48PCS
 Gross Weight/CTN: 16KG

Dust-free dry mill



UE-12A

Industrial dust collection cars grinding solutions- UE provides professional service

MODEL	UE-30	UE-40	UE-55	UE-75	UE-111
POWER	3000W	4000W	5500W	7500W	11000W
Voltage	380V	380V	380V	380V	380V
Electric current	7.2A	9.5A	12.9A	16.7A	28A
Frequency	50Hz	50Hz	50Hz	50Hz	50Hz
AIR FLOW	420m ³ /H	530m ³ /H	700m ³ /H	900m ³ /H	900m ³ /h
Negative pressure	-200mbar	-200mbar	-220mbar	-220mbar	-280mbar
Noise Level	<72dBA	<72dBA	<72dBA	<72dBA	<72dBA
TANK	60L	60L	60L	80L	80L
Insulation class	IP54	IP54	IP54	IP54	IP54
SIZE	1240 x 620 x 1320mm	1180 x 580 x 1150mm	1180 x 580 x 1150mm	1220 x 780 x 1500mm	1220 x 780 x 1500mm

Dynamic suction power regulated to suit requirements reduces energy consumption

The Turbo Centralised dust extractors feature Dynamic Control Technology that maintain constant Vacuum Power for up to 14 work places(work stations). The dynamic control unit automatically reduces the energy consumption to the absolute minimum depending on the number of workplaces in operation saving up to 80 % of energy cost.

This intelligent system controls the relationship between the requested suction power and the required energy. In addition, automatic filter cleaning cycles are carried out continuously, in order to guarantee 100% suction power.

UE-585



- 1 Slide Cleaned Turbine**
Industrial high-power, low noise and continuous working for 24 hours
- 2 Tool Supports**
Convenient to tidy hose and store sander
- 3 Two Units**
For two people to use at the same time
- 4 Multi-Toolhead**
Placing the needed tools and consumables
- 5 Auto Filter Shaker**
Self-cleaning filtration system and convenient to clean

SAVE SPACE

CENTRAL VACUUM SYSTEM
REDUCING OCCUPIED AREA 90%

SAVE ENERGY

INTELLIGENT VARIABLE FREQUENCY CONTROL
SAVING ENERGY 85%

INCREASE EFFICIENCY

THE REMOTE CONTROL PLUS CLEANING
IMPROVING EFFICIENCY 50%

INCREASE SUCTION

PROFESSIONAL MOTOR
INCREASE THE SUCTION 100%



Power (KW)	1.5KW
Voltage (V)	220V
Capacity (m³/h)	1100
Max. Suction (Bar)	0.25
Max. Suction (mmHg)	275.6
Air Flow (m³/h)	220
Filtering area (m²)	2.5
Flow (L/s)	2.5
Working diameter (MM)	300mm
Weight (kg)	102kg



UE-60VB UE-50VB UE-204VB UE-203VB
UE-60VB-2.5/-5/-8 UE-50VB-2.5/-5/-8

Palm-Style 3in.(77) and 5 in. (127 mm) and 6 in. (152 mm) Tool Selector
Standard Product Configuration Table: Random Orbital Sander - 12,000 RPM

Model	Number	Motor (HP)	Nominal Pad (mm)	Air Flow (m³/h)	Product Net (kg)	Height (mm)	Length (mm)	Orbit (mm)
UE-30-2.5	030334	0.28 (209)	3 (77)	17 (481)	1.7 (0.78)	3.5 (88)	7.4 (187)	3 (12 in. 18.8 mm)
UE-50-2.5	050335	0.28 (209)	5 (127)	17 (481)	1.9 (0.87)	3.5 (88)	8.3 (211)	4 (1.5 in. 12.7 mm)
UE-50-5	050307	0.28 (209)	5 (127)	17 (481)	2.0 (0.89)	3.3 (83)	8.0 (219)	3 (1.18 in. 30mm)
UE-50-8	050368	0.28 (209)	5 (127)	17 (481)	2.0 (0.89)	2.5 (69)	8.0 (219)	3 (1.18 in. 30mm)
UE-60-2.5	060300	0.28 (209)	6 (152)	17 (481)	2.0 (0.89)	3.3 (83)	6.4 (162)	3 (1.18 in. 30mm)
UE-60-5	060301	0.28 (209)	6 (152)	17 (481)	2.0 (0.89)	3.5 (88)	6.4 (162)	3 (1.18 in. 30mm)
UE-60-8	060334	0.28 (209)	6 (152)	17 (481)	2.0 (0.91)	3.3 (83)	8.8 (223)	3 (1.18 in. 30mm)



Dust-free dry mill



UE-1500B

power: 1.5Kw / 2.2Kw
cover area: 128m²

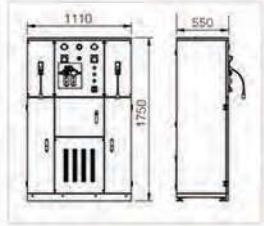

Usde To Dust Room UE -1500B

- <<Industrial-grade brushless motor
- <<Automatic filter cleaning function
- <<Continuous working for 24 hours
- <<For two people to use at the same time
- <<Connected with electric or pneumatic tools



Embedded design

Hose reel



TYPE	SIZE	COVER	CAPACITY	SUPPLY	ELECTRICCURRENT	POWER
UE-1600B	980x450x1900	128m ²	25L	230V-50Hz(Δ) 380V-50Hz(Y)	9.7A(Δ) 5.6A(Y)	2.2Kw 3HP
UE-1500B	980x450x1900	128m ²	25L	230V-50Hz(Δ)	7.5A(Δ)	1.5Kw 2HP

TYPE	QMAX	PRESSURE	NOISE	SOCKET 220V/50Hz	SOCKET 380V/50Hz	OIL AIR	DRY AIR
UE-1600B	318 m ³ /h	2200Pa	65dB(A)	• (1)	• (1)	• (2)	• (2)
UE-1500B	210 m ³ /h	2200Pa	65dB(A)	• (1)	• (1)	• (2)	• (2)

power 1.5Kw / 2.2Kw
cover area 128m²

UE-1500D/UE-1600D



UE-1600D



TYPE	SIZE	COVER	CAPACITY	SUPPLY	ELECTRICCURRENT	POWER
UE-1500D	530x555x1820mm	128m ²	30L	230V-50Hz(Δ)	10.4A(Δ)	1.5Kw
UE-1600D	530x555x1820mm	128m ²	30L	230V-50Hz(Δ) 380V-50Hz(Y)	9.7A(Δ) 5.6A(Y)	2.2Kw 2.2Kw

TYPE	QMAX	PRESSURE	NOISE	SOCKET 220V/50Hz	SOCKET	OIL AIR	DRY AIR
UE-1500D	210m ³ /h	190mbr	65dB(A)	• (1)	• (1)	• (2)	• (2)
UE-1600D	345m ³ /h	200mbr	65dB(A)	• (1)	• (1)	• (2)	• (2)

Dust-free dry mill

UE-1500XB



Long life, nonstop working means more profits
Industrial grade professional draught fan



Auto life filter lub, convenient for
cleansing



Washable filter with long using time
clean emission



Auto cleansing



Safety and energy saving efficient and convenient



SIZE	THE LENGTH OF THE	POWER	THE AIR FLOW
530x555x1820mm	10	1500W	210
MAXIMUM VACUUM	VOLTAGE	SUPPLY	NOISE
190mbar	220V-50Hz	10.4A	63

Dry sanding dust extraction

UE-3580

- Features:
- Double stage power motor
- Removal filter frame with sponge for replacing filter(in rear side of top head)
- With washable fabric filter and paper filter
- Handle with hook for holding power cord
- Waterproof bag(8L capacity)
- Soecmcations:
- Power consumption: 1,200W ± 10%
- Water Mt: 2,274mm / H2O
- Cleaner water capacity(tank): 55L
- Air flow: 2.2m3 / min
- Voltage: 110,220 / 230, 240V
- Current: +/-10%,10.9A/110V,+/-5.2A for 230V



Dust-free dry mill

UE-3588



<p>LOCKERS</p> <p>Lockers and more collections and more convenient tool.</p>  <p>CE [] [] []</p>	<p>PRECISION FILTER</p> <p>Protection of pneumatic tools prolong service life.</p>  <p>CE [] [] []</p>
<p>DUST BUCKET</p> <p>Filter emissions at a more favorable environment.</p>  <p>CE [] [] []</p>	<p>GRINDING PENDANT</p> <p>Suction hose easy to manage, easy to store grinding.</p>  <p>CE [] [] []</p>

- Features:
- Double stage power motor
- Removal filter frame with sponge for replacing filter(in rear side of top head)
- With washable fabric filter and paper filter
- Handle with hook for holding power code
- Waterproof bag(8L capacity)
- Soecmcations:
- Power consumption: 1,200W ± 10%
- Water Mt: 2,274mm / H2O
- Cleaner water capacity(tank): 55L
- Air flow: 2.2m3 / min
- Voltage: 110,220 / 230, 240V
- Current: +/-10%,10.9A/110V,+/-5.2A for 230V

Mobile clean dry grinding system

UE-3600



<p>1 Duplex filter</p> <p>The duplex filter can protect the sander and extend the lifetime of the tools, by means of filtering the moisture and impurities in compressed air.</p> 	<p>2 Tee interface</p> <p>For two people to use at the same time</p> 	<p>3 Vacuum cleaner</p> <p>Dust collecting barrel—Stainless steel Tank capacity: 45L Equipped with Triple filter</p> 
<p>4 Sander hook</p> <p>Convenient to tidy hose and store sander</p> 	<p>5 Dust collector motor</p> <p>Imported with original installation, high-power, high efficiency and heat dissipation, long life</p> 	<p>6 Storage cabinet</p> <p>Storing the needed tools and consumables and avoiding the loss of the accessories</p> 

Dust-free dry mill

UE-3600C



MODEL: UE -3600

power	1200W
power supply	110,220 / 230, 240V
water Mt	2100mm/H:0
Air folw	2.8m ³ /min
Tank capacity	45L
Dimensions	680X700X930mm

MODEL: UE -3600C

power	1200WX2
power supply	110,220 / 230, 240V
water Mt	2300mm/H:0
Air folw	4m ³ /min
Tank capacity	45L
Dimensions	680X700X930mm

VACUUM CLEANER
Professional motor, lasting and durable.

CE [] [] [] []

CIRCUIT BOARD
Use the time accumulated, sound and light alarm, Adjustable speed function.

CE [] [] [] []

PRECISION FILTER
Protection of pneumatic tools prolong service service life.

CE [] [] [] []

SUCTION HOSE
Anti-static, can be any length (3.5m-12m), Operating temperature up to (-40°C -80 °C)

CE [] [] [] []

SANDERS
Low center of gravity, reducing vibration, Environmental design, the central dust collection dust.

CE [] [] [] []



Dust-free dry mill



UE-30D

Suspended central dust collection (four stations)

Voltage: 380V
 Power: 3000W
 Air flow: 420M³/H
 Negative pressure: -200mbar
 Dust collection capacity: 25L
 Filter area: 4m²
 Filter core life: >10000H
 Noise value: <70dBA
 Size: 530*555*1820mm

UE-30D

Central dust collection of closet (four stations)

Voltage: 380V
 Power: 3000W
 Air flow: 420M³/H
 Negative pressure: -200mbar
 Dust collection capacity: 25L
 Filter area: 4m²
 Filter core life: >10000H
 Noise value: <70dBA
 Size: 530*555*1820mm



UE-40B

Suspended central dust collection (six stations)

Voltage: 380V
 Power: 4000W
 Air flow: 530M³/H
 Negative pressure: -200mbar
 Dust collection capacity: 60L
 Filter area: 8m²
 Filter core life: >10000H
 Noise value: <70dBA
 Size: 1314*600*1500mm

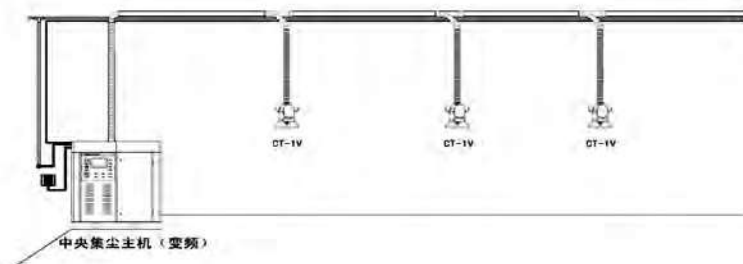

UE-40B

Central dust collection of closet (six stations)

Voltage: 380V
 Power: 4000W
 Air flow: 530M³/H
 Negative pressure: -200mbar
 Dust collection capacity: 60L
 Filter area: 8m²
 Filter core life: >10000H
 Noise value: <70dBA
 Size: 1314*600*1500mm

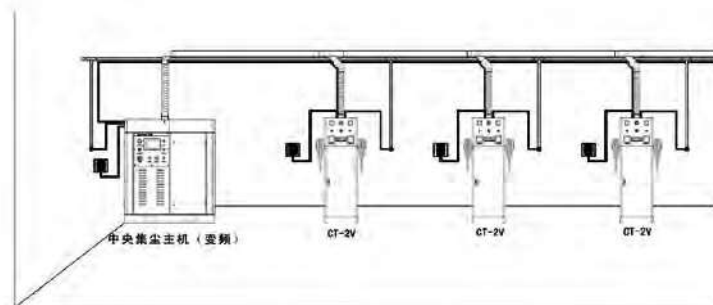

Dust-free dry mill

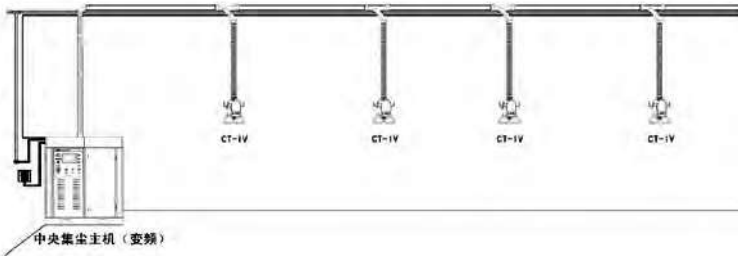

UE-55B Suspended central dust collection (eight stations)

Voltage: 380V
Power: 5500W
Air flow: 700M³/H
Negative pressure: -220mbar
Dust collection capacity: 60L
Filter area: 8m²
Filter core life: >10000H
Noise value: <70dBA
Size: 1314*600*1500mm

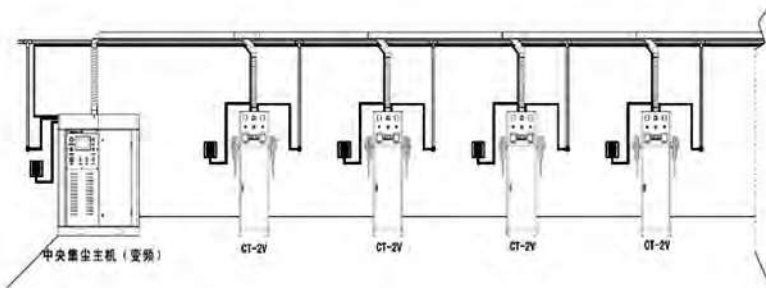

UE-55B Central dust collection of closet (eight stations)

Voltage: 380V
Power: 5500W
Air flow: 700M³/H
Negative pressure: -220mbar
Dust collection capacity: 60L
Filter area: 8m²
Filter core life: >10000H
Noise value: <70dBA
Size: 1314*600*1500mm



UE-3000 Paint mist recycling machine

The paint mist recovery machine adopts a four-stage filtration system, with primary filtration-precision filtration-activated carbon filtration-high efficiency filtration, power 1.5KW/220V, air volume 3000M³/H, noise ≤ 70 decibels. Used for car polishing, intermediate coating, Purify the workshop when the topcoat is repaired, and the effect is better with the soft curtain station



UE-6080 Water-based spray gun cleaning machine

Features:

1. Economical and applicable wall-mounted spray gun cleaning machine
2. Convenient placement, perfect planning space
3. Manually clean the spray gun within 30 seconds
4. Drying and blowing function, fast drying spray gun
5. Through precipitation, the cleaned water can be recycled and reused, which is environmentally friendly and energy-saving.

Dust-free dry mill



UE-602B

Water-based paint blower

1. Save up to 80% drying time
 2. Shorten the time occupied by the spray booth
 3. Improve production efficiency
 4. Can be used alone or with a stand
 5. Especially suitable for small area painting work
 6. Avoid the expensive spray booth from heating up
 7. No need to wait for cooling time
 8. The next process can be carried out immediately
 9. Detachable suction filter for cleaning
- Air pressure: 4 – 4.5Bar
10. Maximum air pressure: 6.8 Bar Air volume: 6000L/min



UE-602

Water-based paint blower

1. Save up to 80% drying time
 2. Shorten the time occupied by the spray booth
 3. Improve production efficiency
 4. Can be used alone or with a stand
 5. Especially suitable for small area painting work
 6. Avoid the expensive spray booth from heating up
 7. No need to wait for cooling time
 8. The next process can be carried out immediately
 9. Detachable suction filter for cleaning
- Air pressure: 4 – 4.5Bar
10. Maximum air pressure: 6.8 Bar Air volume: 6000L/min



UE-280CK

Paint remover set

- Grinding and vacuuming tools: 1 piece
- In addition to rubber wheel: 1 piece
- Paint removal wheel: 1 piece
- Steel brush special wheel: 1 piece
- Copper rust removal wheel: 3 pieces
- Special hexagon wire: 1 piece
- Screw: 1 piece
- Dedicated vacuum interface: 1 piece

UE-620

Paint X bracket

1. Foldable and equipped with extended auxiliary arm spray paint X-type bracket, durable and light
 2. The surface of color-plated zinc iron pipe is painted with paint, which can be used for a long time.
 3. It can be used in roasting rooms, grinding rooms, workstations and other areas
 4. It has the characteristics of beautiful appearance, easy operation and high flexibility
 5. Equipped with adjusting chain and auxiliary arm, which can be adjusted according to the actual size, suitable for various work requirements.
- Packing size: 1192*240*640mm



Dust-free dry mill



UE-680

Rotating machine cover frame

1. The design of the rotating bracket is simple, convenient and practical.
2. The handle and pedal adjustment can be locked at any position to support a variety of different specifications of automobile sheet parts
3. The rotary design is more convenient for the processing requirements of different angles of work
4. The support rod can be adjusted steplessly to a large degree. Up and down, left and right to meet your different needs
5. The rotating bracket is equipped with universal wheels, which is convenient and fast to move, stable and reliable
Packing size: 1250*140*880mm



UE-650

Masking paper holder

The paper cutting holder (masking paper holder) is used for car maintenance, and the cutting of masking paper during spraying is simple and convenient to use and can improve work efficiency.
Packing size: 830*440*1500mm



5 inch 7 holes Sandpaper

Granules, garnet planting glue, resin-coated resin, new and improved technology Backing base, paper base, sand planting method, semi-open type, particle size range P80--600 100 sheets/group



6 inch 15 holes Sandpaper

Granules, garnet planting glue, resin-coated resin, new and improved technology Backing base, paper base, sand planting method, semi-open type, particle size range P80--600 100 sheets/group



6 inch 17 holes Sandpaper

Granules, garnet planting glue, resin-coated resin, new and improved technology Backing base, paper base, sand planting method, semi-open type, particle size range P80--600 100 sheets/group

Dust-free dry mill



95*180 Sandpaper

Granules, garnet planting glue, resin-coated resin, new improved technology Back base, paper base, sand planting method, semi-open type, particle size range P80--240 100 sheets/group



70*200 Sandpaper

Granules, garnet planting glue, resin-coated resin, new improved technology Back base, paper base, sand planting method, semi-open type, particle size range P80--320 100 sheets/group



70*120 Sandpaper

Granules, garnet planting glue, resin-coated resin, new improved technology Back base, paper base, sand planting method, semi-open type, particle size range P80--320 100 sheets/group



6 inch 15 holes Fine grinding sponge sand

Imported raw materials, mainly for the removal of old varnish and the grinding of primer
P400 is mainly used for: primer grinding of dark paint car body and old varnish (old paint leather) grinding.
P600 is mainly used for: grinding of silver powder, pearl powder, light-colored paint primer and old varnish (old paint leather).
P1000 is mainly used for: barge (interface), over-color grinding.



6 inch 17 holes Circular grinder tray



6 inch 17 holes Cushion

Circular grinder cushion, reduce cushioning 6 inches 17 holes

Dust-free dry mill



70*125
Vacuum Hand Grinding Board
70*125MM Vacuum Hand Grinding Board



70*200
Vacuum Hand Grinding Board
70*200MM Vacuum Hand Grinding Board



70*400
Vacuum Hand Grinding Board
70*400MM Vacuum Hand Grinding Board



HD-9
9-piece hand grinding plate
9 sets of hand grinding plates, suitable for manual grinding of different angles and shapes



36L
Dust bag
36L: dust bag, available Festo CTL36/5



125ML
Pneumatic tool oil
Special oil for pneumatic tools, used for cleaning and maintenance of grinding head



UE-TF01
Toner indicator
Polishing indicator set

Dust-free dry mill



UE-50VD—2.5

Eccentric circular grinder

5 inches 6 holes (finishing machine)
Dust-collecting circular fine grinding machine with a stroke of 2.5mm
Fine grinding and final grinding of flat and curved surfaces



UE-50VD—5

Eccentric circular grinder

5 inches 6 holes (finishing machine)
Dust-collecting circular fine grinding machine with a stroke of 5mm
Fine grinding and final grinding of flat and curved surfaces



UE-60VD—2.5

Eccentric circular grinder

6 inches 17 holes (finishing machine)
Dust-collecting circular fine grinding machine with a stroke of 2.5mm
Fine grinding and final grinding of flat and curved surfaces



UE-60VD—5

Eccentric circular grinder

6 inches 17 holes (finishing machine)
Dust-collecting circular fine grinding machine with a stroke of 5mm
Fine grinding and final grinding of flat and curved surfaces



UE-204VB

Square mill

Square 8 holes
Grinding disc seat size-95x180mm(3-2/3"x7")
Net weight -0.94 kg
Air consumption -0.4 m³/min
Air intake screw-1/4"
Intake pipe diameter -3/8"
Idling speed -10000 rpm
Air pressure -6.3 kg/cm² (90 psig)
Deflection diameter-5 mm

Dust-free dry mill



UE-204VD Square mill

Square 8 holes
Grinding disc seat size-70x198mm(3-2/3"x7")
Net weight -0.94 kg
Air consumption -0.4 m³/min
Air intake screw-1/4"
Intake pipe diameter -3/8"
Idling speed -10000 rpm
Air pressure -6.3 kg/cm² (90 psig)
Deflection diameter-5 mm



HOSE35 Vacuum tube

3.5 meters
UE two-in-one dust collection tube adopts rotating interface twist compensation, black dirt resistance, compression resistance, high temperature resistance, specification: 35MM*5M+32MM*1M



HOSE60 Vacuum tube

6 meters
UE two-in-one dust collection tube adopts rotating interface twist compensation, black dirt resistance, compression resistance, high temperature resistance, specification: 35MM*5M+32MM*1M



HOSE90 Vacuum tube

9 meters
UE two-in-one dust collection tube adopts rotating interface twist compensation, black dirt resistance, compression resistance, high temperature resistance, specification: 35MM*5M+32MM*1M

Screw Air Compressor



UE-XLAM7.5A
UE-XLAM10A

■ NEVER DEMAGNETIZATION

The super energy saving machine adopts the permanent magnet motor made of the UH grade Nd-Fe-B magnet permanent magnet material, the temperature resistance is up to 180C, and the permanent magnet motor keeps high efficiency and magnetism for a long time, it never demagnetization.

■ HIGH EFFICIENCY PERMANENT MAGNET SYNCHRONOUS MOTOR

There is no slip, no electric excitation, no fundamental iron in rotor, copper loss and less heat, which can reduce the loss of stator current and stator resistance. Its efficiency is 5-12% higher than that of the same capacity asynchronous motor especially at low speed. The motor can still maintain a high efficiency.

■ MUTE

The super energy series operate safely with low noise; the noise is 68-74 decibels under the full load operation condition.

IP55



68-74



UE-XLAM15A
UE-XLAM20A



UE-XLAM7.5ATD 350L
UE-XLAM10ATD 350L



UE-XLAM15ATD 500L
UE-XLAM20ATD 500L

Model	motor power	displacement / discharge pressure		cooling method / drive mode		size (mm)	weight / noise		air outlet pipe diameter
	KW	(m3 / min)	/ Mpa				Kg	/ d B(A)	
UE-XLAM7.5A	5.5	0.79 / 0.8	0.69/1.0	air cooling	direct drive	840x600x850	185	62±2	G3/4"
UE-XLAM10A	7.5	1.05/0.8	0.92/1.0	air cooling	direct drive	840x600x850	205	62±2	G3/4"
UE-XLAM15A	11	1.61/0.8	1.4/1.0	air cooling	direct drive	910x700x1000	245	63±2	G3/4"
UE-XLAM20A	15	2.13/0.8	1.87/1.0	air cooling	direct drive	910x700x1000	255	63±2	G3/4"
UE-XLAM7.5ATD	5.5	0.79/0.8	0.69/1.0	air cooling	direct drive	1800x600x1580	370	63±2	G3/4"
UE-XLAM10ATD	7.5	1.05/0.8	0.92/1.0	air cooling	direct drive	1800x600x1580	380	62±2	G3/4"
UE-XLAM15ATD	11	1.61/0.8	1.41/1.0	air cooling	direct drive	1800x700x1750	505	63±2	G3/4"
UE-XLAM20ATD	15	2.13/0.8	1.87/1.0	air cooling	direct drive	1800x700x1750	515	63±2	G3/4"

Air Compressor

Model	Voltage	Frequency	Power		Flow		Pressure		Tank		Package Size LxWxH(mm)	N.W. Kgs	G.W. Kgs	QTY/20'CY PCS
			Kw	Hp	Cfm	L/mN	Psi	Bar	L	GALON				
UE-A024L	220	50	1.5	2	6.9	196	116	8	24	6	590x290x630	24	26	225
UE-AE050BM	220	50	1.5	2	6.9	196	116	8	50	13	770x330x730	33	35	156
UE-AE050VFL	220	50	2.2	3	13.9	392	116	8	50	13	770x380x740	41	43.2	126
UE-AE100VFL	220	50	2.2	3	13.9	392	116	8	100	26	1090x400x840	54	57	50
UE-AE100ZA	220	50	2.2	3	10.2	290	116	8	100	26	1090x450x840	64	67	50
UE-AE150ZA	220	50	2.2	3	10.2	290	116	8	150	38.7	1400x520x950	103	106	32
UE-AE020GB	220	50	1.5	2	6.9	196	116	8	77	20	550x420x1245	38	40	50
UE-AE200TD	380	50	3	4	18.5	525	116	8	200	51.6	1400x540x1100	130	142	32
UE-AE300VD	380	50	4	5.5	21.2	600	116	8	300	77.4	1700x570x1190	180	200	12



UE-AE024L
24 L



UE-AE050BM
50 L



UE-AE050VFL
UE-AE100VFL
50 L / 100 L



UE-AE100ZA
UE-AE150ZA 100 L / 150 L



UE-AE020GB
77 L



UE-AE200TD 200 L



UE-AE300VD
300 L

Filter series



Filter series

Product Parameters

Model: UE-03	Applicable pressure: 0.8MPa	Volume: 20L
Model: UE-05	Applicable pressure: 0.8MPa	Volume: 25L
Model: UE-10	Applicable pressure: 0.8MPa	Volume: 30L
Model: UE-20	Applicable pressure: 0.8MPa	Volume: 60L
Model: UE-30	Applicable pressure: 0.8MPa	Volume: 70L

Fine piston series air compressor

UE-0.6-8

Product Parameters

Model: UE-0.6-8
Power(kw/HP): 4/5.5
Voltage(V): 380
Displacement(l/ min): 600
Rated pressure(bar): 8
Cylinder (straight mmX quantity): 90X2
Head speed(rmp): 930
Tank capacity(L): 105
Overall dimensions(mm): 1150X500X850
Net weight(kg): 130



UE-0.8-8

Product Parameters

Model: UE-0.8-8
Power(kw/HP): 5.5/7.5
Voltage(V): 380
Displacement(l/ min): 800
Rated pressure(bar): 8
Cylinder (straight mmX quantity): 90X3
Head speed(rmp): 960
Tank capacity(L): 120
Overall dimensions(mm): 1250X500X900
Net weight(kg): 145

Fine piston series air compressor



UE-0.8-12.5

Product Parameters

Model: UE-0.8-12.5
Power(kw/HP): 5.5/7.5
Voltage(V): 380
Displacement(l/ min): 800
Rated pressure(bar): 12.5
Cylinder (straight mmX quantity): 90X2, 65X1
Head speed(rmp): 960
Tank capacity(L): 120
Overall dimensions(mm): 1250X500X900
Net weight(kg): 145

UE-0.9-8

Product Parameters

Model: UE-0.9-8
Power(kw/HP): 7.5/10
Voltage(V): 380
Displacement(l/ min): 900
Rated pressure(bar): 8
Cylinder (straight mmX quantity): 90X3
Head speed(rmp): 960
Tank capacity(L): 180
Overall dimensions(mm): 1500X500X960
Net weight(kg): 175



UE-0.9-12.5

Product Parameters

Model: UE-0.9-12.5
Power(kw/HP): 7.5/10
Voltage(V): 380
Displacement(l/ min): 900
Rated pressure(bar): 12.5
Cylinder (straight mmX quantity): 90X2, 65X1
Head speed(rmp): 960
Tank capacity(L): 180
Overall dimensions(mm): 1500X500X960
Net weight(kg): 175



Fine piston series air compressor



UE-0.12-8

Product Parameters

Model: UE-0.12-8
Power(kw/HP): 1.1/1.5
Voltage(V): 220
Displacement(l/ min): 120
Rated pressure(bar): 8
Cylinder (straight mmX quantity): 51X2
Head speed(rmp): 980
Tank capacity(L): 70
Overall dimensions(mm): 1000X380X760
Net weight(kg): 60

UE-0.25-8

Product Parameters

Model: UE-0.25-8
Power(kw/HP): 2.2/3
Voltage(V): 220
Displacement(l/ min): 250
Rated pressure(bar): 8
Cylinder (straight mmX quantity): 65X2
Head speed(rmp): 980
Tank capacity(L): 80
Overall dimensions(mm): 1120X400X820
Net weight(kg): 81



UE-0.36-8

Product Parameters

Model: UE-0.36-8
Power(kw/HP): 3/4
Voltage(V): 220/380
Displacement(l/ min): 360
Rated pressure(bar): 8
Cylinder (straight mmX quantity): 65X3
Head speed(rmp): 980
Tank capacity(L): 95
Overall dimensions(mm): 1120X440X820
Net weight(kg): 115



Fine piston series air compressor



UE-1.0-14

Product Parameters

Model: UE-1.0-14
Power(kw/HP): 7.5/10
Voltage(V): 380
Displacement(l/ min): 1000
Rated pressure(bar): 14
Cylinder (straight mmX quantity): 90X2, 65X1
Head speed(rmp): 960
Tank capacity(L): 180
Overall dimensions(mm): 1500X500X960
Net weight(kg): 180

UE-1.05-14

Product Parameters

Model: UE-1.05-14
Power(kw/HP): 7.5/10
Voltage(V): 380
Displacement(l/ min): 1050
Rated pressure(bar): 14
Cylinder (straight mmX quantity): 105X2, 55X2
Head speed(rmp): 760
Tank capacity(L): 300
Overall dimensions(mm): 1520X600X1150
Net weight(kg): 295



UE-1.6-8

Product Parameters

Model: UE-1.6-8
Power(kw/HP): 11/15
Voltage(V): 380
Displacement(l/ min): 1600
Rated pressure(bar): 8
Cylinder (straight mmX quantity): 100X3
Head speed(rmp): 860
Tank capacity(L): 320
Overall dimensions(mm): 1620X620X1200
Net weight(kg): 330

Fine piston series air compressor



UE-2.0-8

Product Parameters

Model: UE-2.0-8
Power(kw/HP): 15/20
Voltage(V): 380
Displacement(l/ min): 2000
Rated pressure(bar): 8
Cylinder (straight mmX quantity): 120X3
Head speed(rmp): 860
Tank capacity(L): 320
Overall dimensions(mm): 1620X620X1250
Net weight(kg): 360

UE-LCV1.05-14

Product Parameters

Model: UE-LCV1.05-14
Power(kw/HP): 11/15
Voltage(V): 12
Displacement(l/ min): 1050
Rated pressure(bar): 14
Cylinder (straight mmX quantity): 105X2, 55X2
Head speed(rmp): 860
Tank capacity(L): 300
Overall dimensions(mm): 1650X600X1340
Net weight(kg): 390



UE-LCW1.0-14

Product Parameters

Model: UE-LCW1.0-14
Power(kw/HP): 7.5/10
Voltage(V): 12
Displacement(l/ min): 1000
Rated pressure(bar): 14
Cylinder (straight mmX quantity): 90X2, 65X1
Head speed(rmp): 900
Tank capacity(L): 160
Overall dimensions(mm): 1360X460X1140
Net weight(kg): 240

Fine piston series air compressor



UE-LCZ0.9-12.5

Product Parameters

Model: UE-LCZ0.9-12.5
 Power(kw/HP): 7.5/10
 Voltage(V): 12
 Displacement(l/ min): 900
 Rated pressure(bar): 12.5
 Cylinder (straight mmX quantity): 105X1, 55X1
 Head speed(rmp): 800
 Tank capacity(L): 160
 Overall dimensions(mm): 1360X460X1140
 Net weight(kg): 255

Fine screw series air compressor

Product Parameters

Model	UE7.5-8G	UE11-8	UE11-10	UE11-13
Exhaust pressure (Mpa)	0.8	0.8	1.0	1.3
Displacement (m ³ / min)	1.2	1.7	1.5	1.2
Motor power rate (kW)	7.5	11	11	11
Exhaust connection	G3/4	G1	G1	G1
Noise (dB)	70	72	72	72
Weight (kg)	200	370	370	370
Overall dimensions (mm)	800X620X800	1020X820X1150	1020X820X1150	1020X820X1150



Product Parameters

Model	UE18-8	UE18-10	UE18-13
Exhaust pressure (Mpa)	0.8	1.0	1.3
Displacement (m ³ / min)	3	2.7	2.3
Motor power rate (kW)	18.5	18.5	18.5
Exhaust connection	G1	G1	G1
Noise (dB)	74	74	74
Weight (kg)	500	500	500
Overall dimensions (mm)	1080X880X1235	1080X880X1235	1080X880X1235

Fine screw series air compressor



Product Parameters

Model	UE30-8	UE30-10	UE30-13
Exhaust pressure (Mpa)	0.8	1.0	1.3
Displacement (m ³ / min)	5.0	4.4	3.6
Motor power rate (kW)	30	30	30
Exhaust connection	G1½	G1½	G1½
Noise (dB)	75	75	75
Weight (kg)	650	650	650
Overall dimensions (mm)	1120X930X1290	1120X930X1290	1120X930X1290

Product Parameters

Model	UE45-8	UE45-10	UE45-13
Exhaust pressure (Mpa)	0.8	1.0	1.3
Displacement (m ³ / min)	7.1	6.5	5.6
Motor power rate (kW)	45	45	45
Exhaust connection	G1½	G1½	G1½
Noise (dB)	78	78	78
Weight (kg)	820	820	820
Overall dimensions (mm)	1240X1030X1595	1240X1030X1595	1240X1030X1595



Product Parameters

Model	UE15-8	UE15-10	UE15-13
Exhaust pressure (Mpa)	0.8	1.0	1.3
Displacement (m ³ / min)	2.4	2.2	1.7
Motor power rate (kW)	15	15	15
Exhaust connection	G1	G1	G1
Noise (dB)	73	73	73
Weight (kg)	380	380	380
Overall dimensions (mm)	1020X820X1150	1020X820X1150	1020X820X1150



Fine screw series air compressor



Product Parameters

Model	UE22-8G	UE22-8	UE22-10	UE22-13
Exhaust pressure (Mpa)	0.8	0.8	1.0	1.3
Displacement (m ³ / min)	3.6	3.6	3.2	2.7
Motor power rate (kW)	22	22	22	22
Exhaust connection	G1	G1	G1	G1
Noise (dB)	74	74	74	74
Weight (kg)	560	540	540	540
Overall dimensions (mm)	1410X850X1120	1080X880X1235	1080X880X1235	1080X880X1235

Product Parameters

Model	UE37-8G	UE37-8	UE37-10	UE37-13
Exhaust pressure (Mpa)	0.8	0.8	1.0	1.3
Displacement (m ³ / min)	6.0	6	5.5	4.6
Motor power rate (kW)	37	37	37	37
Exhaust connection	G1½	G1½	G1½	G1½
Noise (dB)	76	76	76	76
Weight (kg)	740	730	730	730
Overall dimensions (mm)	1530X900X1230	1240X1030X1435	1240X1030X1435	1240X1030X1435



Product Parameters

Model	UE55-8	UE55-10	UE55-13
Exhaust pressure (Mpa)	0.8	1.0	1.3
Displacement (m ³ / min)	9.5	8.5	7.4
Motor power rate (kW)	55	55	55
Exhaust connection	G1½	G1½	G1½
Noise (dB)	80	80	80
Weight (kg)	1200	1200	1200
Overall dimensions (mm)	1540X1200X1470	1540X1200X1470	1540X1200X1470

Oil-free silent series air compressor



UE-35

Product Parameters

Model: UE-35

Power(kw): 0.85

Voltage(V): 220

Displacement(l/ min): 120

Rated pressure(bar): 8

Head speed(rmp): 1400

Tank capacity(L): 35

Overall dimensions(mm): 620X300X570

Net weight(kg): 26



UE-70

Product Parameters

Model: UE-70

Power(kw): 2X0.85

Voltage(V): 220

Displacement(l/ min): 240

Rated pressure(bar): 8

Head speed(rmp): 1440

Tank capacity(L): 70

Overall dimensions(mm): 750X400X700

Net weight(kg): 48



UE-90

Product Parameters

Model: UE-90

Power(kw): 3X0.85

Voltage(V): 220

Displacement(l/ min): 360

Rated pressure(bar): 8

Head speed(rmp): 1440

Tank capacity(L): 90

Overall dimensions(mm): 1050X400X750

Net weight(kg): 78

Oil-free silent series air compressor



UE-120

Product Parameters

Model: UE-120
Power(kw): 4X0.85
Voltage(V): 220
Displacement(l/ min): 480
Rated pressure(bar): 8
Head speed(rmp): 1400
Tank capacity(L): 120
Overall dimensions(mm): 1200X410X750
Net weight(kg): 105



UE-120A/B

Product Parameters

Model: UE-120A/B
Power(kw): 3X1.5
Voltage(V): 220/380
Displacement(l/ min): 600
Rated pressure(bar): 8
Head speed(rmp): 1400
Tank capacity(L): 120
Overall dimensions(mm): 1200X410X900
Net weight(kg): 105



UE-220A/B

Product Parameters

Model: UE-220A/B
Power(kw): 4X1.5
Voltage(V): 220/380
Displacement(l/ min): 800
Rated pressure(bar): 8
Head speed(rmp): 1400
Tank capacity(L): 200
Overall dimensions(mm): 1500X450X9500
Net weight(kg): 160

Precision filter series



Product parameters

Compressed air precision filter

Model	long (mm)	B(diameter) mm	Handling air M/min	Pipe diameter pn	Filter element Q/P/S/C	Maximum pressure bar.g
UE-015	267.5	89.0	1.5	3/4"	1X015	12
UE-024	513.5	109.0	2.5	1.5"	1X024	12
UE-035	513.5	109.0	3.5	1.5"	1X035	12
UE-060	513.5	109.0	7.0	1.5"	1X060	12
UE-090	550.0	133.0	11.0	2.5"	1X090	10
UE-120	928.0	133.0	15.0	2.5"	1X120	10
UE-150	928.0	133.0	17.0	2.5"	1X150	10
UE-200	900.0	160.0	24.0	2.5"	1X200	10
UE-240	1225.5	219.0	28.0	2.5"	1X150	10
UE-300	1225.0	219.0	32.0	2.5"	3X120	10
UE-360	1350.0	275.0	36.0	3"	3X120	10
UE-450	1350.0	275.0	45.0	3"	3X120	10
UE-600	1250.0	325.0	60.0	4"	4X150	9
UE-750	1250.0	375.0	75.0	5"	5X150	9
UE-900	1810.0	425.0	90.0	6"	6X150	8
UE-1200	1895.0	625.0	120.0	8"	8X150	8
UE-1500	1900.0	675.0	150.0	10"	10X150	8

Freeze desiccant series



Product parameters

Air-cooled energy-saving freeze-dryer (inlet temperature ≤80 degrees)

Model	Air capacity (m ³ /min)		Compressor power (KW)	Voltage (V)	Pipe diameter	Overall dimensions (mm) L*W*H			weight (kg)
UE-7.5AC	1.0	35	0.3	220	W"	600	410	640	38
UE-10AC	1.5	53	0.35	220	1"	750	420	730	52
UE-15AC	2.0	71	0.5	220	1"	750	420	730	65
UE-20AC	2.5	88	0.75	220	1 1/4"	800	440	800	73
UE-25AC	3.0	106	0.75	220	1 1/2"	800	440	800	80
UE-30AC	3.8	124	0.75	220	1 1/2"	930	500	870	92
UE-40AC	5.1	176	1	220	1 1/2"	930	500	910	100
UE-50AC	6.7	230	1.5	220	1 1/2"	980	570	970	115
UE-60AC	8.1	282	1.5	220	2"	980	570	1010	136
UE-75AC	10.7	371	2	220	2 1/2"	1100	600	1040	160
UE-100AC	13.8	477	2.75	380	2 1/2"	1390	780	1270	210
UE-120AC	15.1	530	4	380	2 1/2"	1250	780	1270	235
UE-150AC	20	706	5	380	F3"	1250	780	1270	265
UE-180AC	25	883	5.5	380	F3"	1380	750	1400	293
UE-200AC	27.5	1006	5.8	380	F3"	1380	750	1400	325
UE-250AC	30	1059	7.5	380	F3"	1500	900	1400	386
UE-300AC	35.5	1236	7.5	380	F4"	1500	900	1400	430
UE-400AC	45.6	1360	7.5	380	F4"	1500	900	1400	430

Air Compressor



AIR SUPPLY SYSTEM DESIGN AND INSTALLATION



PRECISION FILTER



(PERSON WHO)



STORAGE TANKS



YOYO-810A

Technical Parameters

- Power: 7.5KW
- Free air deliver: 1.1m³/min
- Discharge pressure: 0.8MPa
- Lubricant: 12L
- Drive method: Multivee belt
- Noise Level: 66±2
- Air outlet Pipe Diameter: 3/4"
- Weight: 240kg
- Dimension: 800x720x900mm

Air Compressor



YOYO-830A

Technical Parameters

- Power: 22KW
- Free air deliver: 3.6m³/min
- Discharge pressure: 0.8MPa
- Lubricant: 18L
- Drive method: Multivee belt&Direct
- Noise Level: 68±2
- Air outlet Pipe Diameter: 3/4"
- Weight: 580kg(M) 620kg(D)
- Dimension: 1150x900x1380mm(M)
1380x850x1150mm(D)



YOYO-810A

Technical Parameters

- Power: 5.5KW
- Free air deliver: 0.8/0.7/0.6
- Discharge pressure: 0.8/1.0/1.3
- Lubricant: 30L
- Air tank capacity: 0.3m³
- Dimension: 1300x1000x1470mm(M)
1600x1000x1370mm(D)



UE-10A

- Working pressure / Mpa: 0.8/1.0/1.3
- Displacement m³/ min: 1.0/0.9/0.8
- Power / KW: 7.5
- Gas tank volume / m³: 0.3
- power supply: 380v
- Dimension: 1580*640*1330mm

94 new energy tool carts



Serial number: 6692A
20 sets of 12.5mm insulated sleeve tool



Serial number: 6692B
25 sets of 10mm insulated sleeve and T wrench tool holder



Serial number: 6692C
19 sets of insulated screwdriver/pliers tool holder



Serial number: 6692D
13 sets for insulated box wrench tools



Serial number: 6692E
16 sets for insulated open end wrench tools



314 new energy tool carts



Serial number: 6684A
33 sets of insulated sleeve type tools



Serial number: 6684B
22 sets of insulated screwdriver/pliers tool holder



Serial number: 6682A
131 sets of sleeves and rotary head tools



Serial number: 6682C
37 sets of maintenance tools



Serial number: 6682D
45 sets of integrated tools



Serial number: 6682E
38 wrench tool holder sets



▼ Megger(optional) ▼ Milliohmmeter (optional) ▼ New cross wrench (with iron clamp) ▼ Wired highlighted LED working light (36 beads)



199 comprehensive tool carts



1/4" & 1/2" Socket Set 131pc



Wrench and Screw Driver Set 49pc



Integrated tool set 19pc



200 comprehensive tool carts



1/4" & 1/2" Socket Set 126pc



40PCS Integrated Tool Set



43PCS Integrated Tool Set



217 comprehensive tool carts



41PCS Integrated Tool Set



50PCS Integrated Tool Set



1/4" & 1/2" Socket Set 126pc



231 Mercedes-Benz cars Tool



Serial number: 6670A
104 sets of sleeve type tools



Serial number: 6670B
52 wrench, screwdriver socket tool bracket



Serial number: 6670C
17 sets of pliers and screwdriver tools



Serial number: 6670D
21 sets of comprehensive tools



Serial number: 6671A
21 sets of mercedes-benz special tools set A



Serial number: 6671B
8 sets of mercedes-benz special tools set B



Leaf plate protector ▼ 4piece T hexagon socket wrench ▼ Wired highlighted LED working light (36 beads)



232 Audi tool carts



Serial number: 6670A
104 sets of sleeve type tools



Serial number: 6670B
52 wrench, screwdriver socket tool bracket



Serial number: 6670C
17 sets of pliers and screwdriver tools



Serial number: 6670D
21 sets of comprehensive tools



Serial number: 6673A
25 sets of audi special tools set A



Serial number: 6673B
8 sets of audi special tools set B



Leaf plate protector ▼ 4piece T hexagon socket wrench ▼ Wired highlighted LED working light (36 beads)



233 BMW tool carts



Serial number: 6670A
104 sets of sleeve type tools



Serial number: 6670B
52 wrench, screwdriver socket tool bracket



Serial number: 6670C
17 sets of pliers and screwdriver tools



Serial number: 6670D
21 sets of comprehensive tools



Serial number: 6672A
20 sets of BMW special tools set A



Serial number: 6672B
9 sets of BMW special tools set B



Leaf plate protector ▼ 4piece T hexagon socket wrench ▼ Wired highlighted LED working light (36 beads)



313 Mercedes-Benz cars Tool



Serial number: 6687A
135 sets of sleeve tools



Serial number: 6688B
Set of 34 wrench tools



Serial number: 6688C
17 sets of pliers screwdriver tools



Serial number: 6699D
60 sets of auto maintenance tools



Serial number: 6678V
35-piece camshaft disassembly / timing correction tool holder



Serial number: 6678W
28 sets of camshaft dismounting / timing correction tools



Serial number: 6678C
3 timing tool sets (optional)



T type hexagon socket wrench

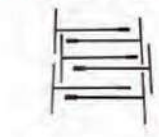

345 Audi tool carts



Serial number: 6687A
135 sets of sleeve tools



Serial number: 6688B
Set of 34 wrench tools



Serial number: 6688C
17 sets of pliers/screwdriver tools



Serial number: 6699D
60 sets of auto maintenance tools



Serial number: 6699E
35 sets of special tools for auto repair



Serial number: 6679B
15 sets for timing tools



Serial number: 6679C
15 sets for timing tools



Serial number: 6679D
33 timing tool sets



355 BMW tool carts



Serial number: 6687A
135 sets of sleeve tools



Serial number: 6688B
Set of 34 wrench tools



Serial number: 6688C
17 sets of pliers/screwdriver tools



Serial number: 6699D
60 sets of auto maintenance tools



Serial number: 6677A
19-piece engine mounting/locking tool holder



Serial number: 6677C
18 engine timing tool holder



Serial number: 6677D
18 engine timing tool holder



Serial number: 6677E
29-piece dual camshaft mounting /locking tool holder



Serial number: 6677F
24-piece twin camshaft dismounting / timing adjustment tool holder



Serial number: 6677B(optional)
24 sets for peeling gasket fixing /spring handling tools



Tool trolley



UE-81 Double door tool cart

Length: 77.5cm
Width: 45cm
Height: 95cm
Weight: 32kg
Loading capacity: 250kg
Material: 1.0 mm thickness cold roll steel
Loading capacity of drawer: 45kg.
Drawers: 1 drawer



UE-82 Drawer double door tool cart

Length: 77.5cm
Width: 45cm
Height: 95cm
Weight: 38kg
Loading capacity: 250kg
Material: 1.0 mm thickness cold roll steel
Loading capacity of drawer: 45kg.
Drawers: 2 drawers



UE-83 Drawer type tool cart

Length: 77.5cm
Width: 45cm
Height: 95cm
Weight: 38kg
Loading capacity: 250kg
Material: 1.0 mm thickness cold roll steel
Loading capacity of drawer: 45kg.
Drawers: 3 drawers



UE-84 Drawer type tool cart

Length: 77.5cm
Width: 45cm
Height: 95cm
Weight: 48kg
Loading capacity: 250kg
Material: 1.0 mm thickness cold roll steel
Loading capacity of drawer: 45kg.
Drawers: 4 drawers



UE-85 Drawer type tool cart

Length: 77.5cm
 Width: 45cm
 Height: 95cm
 Weight: 49kg
 Loading capacity: 250kg
 Material: 1.0 mm thickness cold roll steel
 Loading capacity of drawer: 45kg.
 Drawers: 5drawer



UE-86 Drawer type tool cart

Length: 77.5cm
 Width: 45cm
 Height: 95cm
 Weight: 51kg
 Loading capacity: 250kg
 Material: 1.0 mm thickness cold roll steel
 Loading capacity of drawer: 45kg.
 Drawers: 6drawer



UE-87 Drawer type tool cart

Length: 77.5cm
 Width: 45cm
 Height: 95cm
 Weight: 54kg
 Loading capacity: 250kg
 Material: 1.0 mm thickness cold roll steel
 Loading capacity of drawer: 45kg.
 Drawers: 7drawer



UE-88 Drawer type tool cart

Length: 83cm
 Width: 50cm
 Height: 129cm
 Weight: 65kg
 Loading capacity: 250kg
 Material: 1.0 mm thickness cold roll steel
 Loading capacity of drawer: 45kg.
 Drawers: 4drawer

Tool trolley



UE-860

Drawer type accessories tool cart

Length: 96cm
Width: 53cm
Height: 105cm
Weight: 63kg
Loading capacity: 200kg
Material: 1.0 mm thickness cold roll steel
Loading capacity of drawer: 45kg.
Drawers: 5 drawer



UE-8100

Accessories tool cart

Length: 79cm
Width: 36.5cm
Height: 74cm
Weight: 15kg
Loading capacity: 200kg
Material: 1.0 mm thickness cold roll steel



UE-861

Special tool cart for quick repair

Length: 82cm
Width: 80cm
Height: 112cm
Weight: 64kg
Air Pressure: 1-5kg/m²



UE-8300

Double-opening tool cart

Length: 76.5cm
Width: 38.5cm
Height: 80cm
Weight: 30kg
Loading capacity: 200kg
Material: 1.0 mm thickness cold roll steel

Tool trolley



UE-T83 Drawer workbench

Overall dimensions
Length: 150cm
Width: 80cm
Height: 139cm
Pegboard dimensions
Length: 150cm
Width: 30cm
Height: 60cm
Weight: 130kg
20 hooks equipped



UE-T84 Accessories workbench

Length: 150cm
Width: 80cm
Height: 143.5cm
Weight: 113kg
16 hooks equipped
Cabinet size
Length: 150cm
Width: 25cm
Height: 64.5cm



UE-T81 Ordinary workbench

Length: 150cm
Width: 80cm
Height: 79cm
Weight: 59kg



UE-T82 Drawer workbench

Length: 150cm
Width: 80cm
Height: 79cm
Weight: 113kg



Tool trolley



UE-T85 Drawer workbench

Overall dimensions
 Length: 150cm
 Width: 80cm
 Height: 139cm
 Pegboard dimensions
 Length: 141cm
 Width: 25cm
 Height: 64.5cm
 Weight: 93kg
 20 hooks equipped



UE-T86 Drawer type single door workbench

Overall dimensions
 Length: 150cm
 Width: 81cm
 Height: 155cm
 Pegboard dimensions
 Length: 150cm
 Width: 33cm
 Height: 80cm
 Weight: 145kg
 the average loading of drawers is 40kg
 20 hooks equipped



UE-T83P Tool holder

Overall dimensions
 Length: 126cm Width: 159cm
 Height: 199cm Weight: 120kg
 Pegboard dimensions
 Length: 173.2cm Width: 80cm
 Material: 0.3cm
 Both sides are available
 Loading capacity of pegboard: 100kg
 120 hooks equipped



UE-T85P Tool holder

Overall dimensions
 Length: 196cm Width: 159cm
 Height: 199cm Weight: 195kg
 Pegboard dimensions
 Length: 173.2cm Width: 80cm
 Material: 0.3cm
 Both sides are available
 Loading capacity of pegboard: 100kg
 200 hooks equipped

Intelligent light detector



UE-6109

Main Features and Specifications

Integrated structure of embedded industrial PC. With CMOS machine vision camera and high-speed MSP (mixed signal processing) technology, online headlight adjustment can be done and various parameters of high-beam and low-beam can be measured quickly and accurately; High-brightness big LCD screen, English menu; Fast photoelectric scanning positioning eliminates interfaces from heterogeneous lights, automatic identification and judgment of complicated light shapes, automatic calibration and adjustment by software; Equipped with RS-232C communication port and Ethernet port, various test mode settings are available for stand-alone measurement, system controlled or host-computer controlled measurement. It is suitable for Vehicle manufacturers, test stations and R&D institutes.

Measuring Range

Luminous intensity 0-120,000cd
Optic axis deviation of high beam and low beam
Left-Right: L2°30'-R2°30' (L50cm/10m-R50cm/10m) ,Up-Down: U1°30'-D2°30'
(U20cm/10m-D50cm/10m)
Luminous intensity of high beam
Luminous intensity of high beam: ±12%, Luminous intensity of low beam: ±15'
Optic axis deviation of high beam ±12'
Luminous intensity of low beam ±15'
Central elevation of headlight 40-140cm
Indication error of central elevation ±1cm
Measuring distance 1m



UE-8000/8101

Main Features and Specifications

Measure luminous intensity, headlight elevation and optic axis deviation of headlights on automobiles and motorcycles. Equipped with LCD screen for English menu display, standard RS232 communication port, simulated data output port, laser positioning and optional low-consumption batter (some functions are optional for UE-8000). It is very suitable for measuring and adjusting headlight beam emitting positions on vehicle test lines, workshops, 3S/4S shops.

Measuring Range

Luminous intensity: 0-120,000cd
Optic axis deviation of high beam and low beam
Up-Down: U 1°30'-D 2°30' (U 20cm/10m-D 40cm/10m)
Left-right: L 2°30'-R 2°30' (L 40cm/10m-R 40cm/10m)
Indication Error:
1、Luminous intensity of high beam: ±12%
2、Optic axis deviation of high beam: ±12'
3、Luminous intensity of low beam: ±15'
4、Central elevation of headlight: ±1cm

Exhaust gas analyzer



Product Parameters

Measuring Range:

HC: 0~10000 $\times 10^{-6}$ CO: 0~10 $\times 10^{-2}$ (%)
 CO₂: 0~20 $\times 10^{-2}$ (%) O₂: 0~25 $\times 10^{-2}$ (%)
 NO: 0~5000 $\times 10^{-6}$

Indication Error:

HC: $\pm 10 \times 10^{-6}$ (absolute error) or $\pm 5\%$ (relative error)
 CO: $\pm 0.03 \times 10^{-2}$ (%) (absolute error) or $\pm 5\%$ (relative error)
 CO₂: $\pm 0.5 \times 10^{-2}$ (%) (absolute error) or $\pm 5\%$ (relative error)
 O₂: $\pm 0.1 \times 10^{-2}$ (%) (absolute error) or $\pm 5\%$ (relative error)
 NO: $\pm 25 \times 10^{-6}$ (absolute error) or $\pm 4\%$ (relative error)
 Warm-up Time: 8 min. (3 min. warm-up for fast measurement)
 Response Time: Less than 10s; No, less than 15s

Features

Portable style; ISO 3930 or QIML R99 class 0 accuracy; Measure concentration of HC, CO, CO₂; O₂ and NO (not for NHA-402EN) contained in exhaust gases from gasoline vehicle engine and value; High-brightness big LCD screen; one-to-one-correspondence keys and menu options; English menu; CNG, LPG, ethanol cars can be tested; Standard inductive RPM measurement adaptor; USB flash disk for data transmission and data storage; 3 minutes warm-up for fast measurement.

Speed Test Station



Product Parameters

Rated Load Mass: 10000kg (Custom variable)
 Distance Between Left Roller and Right Roller: 750mm (Inside) \times 2950 (outer)
 Roller Diameter \times Length: 216 \times 1100mm
 Center distance of Roller: 480mm
 Measurement Range: 0~120km/h
 External Dimension (L \times W \times H): 3350 \times 860 \times 445mm
 Pressure of Compression Air: 0.6~0.8MPa

Features

Speedometer tester is for testing the indication error of vehicle speedometer. When a vehicle is driven on the test bench, performance and indication error of the speedometer can be tested at driving speed of 0~120 km/h, and determine whether the speedometer is qualified or not. It is one of the necessary equipments for vehicle safety test and comprehensive performance test.

Main construction and characteristics of NHM series Speedometer Tester:

1. Overall square steel tubes and carbon steel construction welding are adapted for the bench, with structural precision, high strength and rolling compaction resistance;
2. The roller surface is with chrome-plated knurled treatment, it is durable and the vehicle tires are wear-free.
3. With high-precision speed sensor to ensure stable and reliable test accuracy.
4. Air springs are adopted for the lift, lifting is fast, reliable maintenance is easy.
5. Star elastic coupling is used in the transmission system, the transmission power is good and with low noise, the service life is long, installation and adjustment are easy.

Tunnel type gantry car washing machine



Product features

- Body frame independent modular mortise and tenon structure design
- Multi-diamond curved door head
- Concave automatic rectifying frequency conversion conveying system
- 3 d curved Angle seamless embrace large vertical brush cleaning series
- Ten thousand step instruction operation, intelligent error correction PLC control system
- Intelligent detection and identification security protection system
- Intelligent simplex multi-function touch control and remote control operating system
- Intelligent mute fan swing high pressure pre-wash system
- 35 degree high soft no trace brush cleaning system
- Intelligent multi-function car wash liquid proportioning system
- Intelligent error correction start stop anti collision air drying system

Touchless car washing machine

Product features

- The body is surrounded by 360 degrees flush
- 360 degree surround spray car wash
- Automatic spray color bubble
- Wax coating
- Safety detection system
- Multinomial regulation function
- Intelligent metering ratio
- Car washing statistics
- Drainage antifreezing
- Intelligent fault detection
- Multi-mode operation setting
- Parking assistance system
- One button mode
- Self maintenance
- Air drying system (optional 10 thousand)



Touchless car washing machine

UE-1180



Forge Type-Product Configuration Table		Basic-technical parameters	
1	• Standard car wash mode	Project	Parameter
2	• Intensive car wash mode	Dimensions (length * width * height)	3200*1000*700 (mm)
3	• Safe anti-collision function system	Installation requirements (length * width * height)	6200*3400*3000 (mm)
4	• Chassis flushing function	Larger washing height	2000 (mm)
5	• 360-degree full vehicle high-pressure flushing function	Larger car wash width	2200mm
6	• 360-degree spraying of car wash liquid function	Larger washing length	5900mm
7	• Car wash statistics	Power requirements	380v/16Kw
8	• Remote control operation	Car wash speed	90 seconds/car
9	• Fault self-check function	Packing volume	6 cubic
10	• Operation authority system	Total weight of equipment	1600Kg
11	• Oil-free function	track	2 (6m)
12	• Hot-dip galvanized mounting frame	Water Consumption	180 liters/car
13	• Washing antifreeze drainage device	power consumption	0.5 yuan/car
14	• LED signs	Car wash liquid dosage	0.5 yuan/car
15	• Human-machine interface color touch screen	Drive System	Stepless frequency conversion speed regulation
16	• Water wax polishing function	Detection Systems	Ultrasonic body length detection system
17	• Magic color foam function	CPU	Embedded CPU + PLC dual-core system
18	• Built-in automatic air dryer		
19	• Colorful bubbles		
20	• Voice guidance		

Note: • Some items ◯ No such item (Customers can also choose more car wash projects according to their own needs)

Equipment accessories name/brand/power			
German brand high pressure water pump	PINFL	Water pump motor power	Shanghai Electric (11Kw)
Rotating motor	370W stepless frequency conversion speed regulation	Longitudinal drive motor	370W stepless frequency conversion speed regulation
PLC controller	Taiwan Delta	Color touch screen	Taiwan Delta
Ultrasonic sensor	Pepperl+Fuchs	photoelectric sensor	Bonner
Proximity sensor	Schneider	Frequency converter	Taiwan Delta
Contactor	Schneider	Relay	Omron
Switching power supply	Mingwei Taiwan	Fan motor power	Shanghai Electric 3KW*4 units

Gantry fully automatic computer car washer



UE-528-C

Main control appliances	Schneider Electric
Track length	6000MM
Foam system	1 set
Machine length	900MM
Swing waterjet	12 sets
Machine width	3100MM
Ground spray system	10 groups
Machine height	2500MM
High pressure pumps	Taiwan
Effective car wash width	2300MM
Machine shell	Using hot-dip galvanizing and outdoor powder paint
Effective car wash height	2000MM
remote control	1 set
Power consumption	0.3 degrees for 1 car
Air drying system	Optional
Can choose colour	Red, yellow, blue, white, green

Gantry car washing machine



Latest roll over automatic outdoor brush cleaning car wash machine
UE-7brush/5brush/5brush(without dryer)

Models	7brush	5brush	5brush(without dryer)
Machine dimensions L*W*H(m)	2.5*3.7*2.9m	2.5*3.7*2.9m	1.5*3.5*2.8m
Car size:W*H	2.0*2.0	2.0*2.0	2.0*2.0
Conveyor length	11.0m	10.0m	10.0m
The use of area	14.0*4.0m	12.0*4.0m	12.0*4.0m
Power supply	380V	380V	380V
The use of electric power	21KW	20KW	8KW
Water consumption	100L-150L/car	100L-150L/car	100L-150L/car
Washing capacity	20cars/h	20cars/h	20cars/h
Top trush	1set	1set	1set
Long brush	2sets	2sets	2sets
Short brush	2sets	2sets	2sets
Wheel brush	2sets	/	/
dryer	4 blowers	4 blowers	/
High pressure water jet system	1set	1set	1set
Bottom spraying	option	option	option

Intelligent dry ice washer

Supporting protective tools and tools



> Application field



Automotive and aftermarket



Electronic industry



Food and drink



Printing house



General manufacture



Power industry



Casting mould



Paper industry

Steam cleaner



Ice maker



UE-500-3

External dimensions: height 1.4 length 3.2 width 1.4m
Weight: about 1500 kg
Motor power: 11 kW 380V
Control: PLC
Oil pump: Vic 63YCY plunger pump
Inlet valve: 220V19
Capacity: 3 mm, 19 mm, 500 kg per hour
Conversion rate: 42%
Hydraulic oil: No. 46 anti-wear hydraulic oil
Power cord: 10
Inlet pipe: 1 meter +
Inlet valve: 20#1
Tools: 1 set of commonly used
Electric impact wrench: one



UE-1000-3

External dimensions: height 1.8 length 3.2 width 1.4m
Weight: about 2000 kg
Motor power: 18.5kw 380V
Control: PLC
Oil pump: Vic 100YCY plunger pump
Inlet valve: 220V19
Capacity: 3 mm, 19 mm, 900 kg per hour
Conversion rate: 42%
Hydraulic oil: No. 46 anti-wear hydraulic oil
Power cord: 10
Inlet pipe: 1 meter +
Inlet valve: 20#1
Tools: 1 set of commonly used
Electric impact wrench: one

Exhaust extraction machine



UE-111

Weight: 47KG
Power: 0.25kw
Voltage: 220V
Diameter: 75mm

Commercial car washer



UE-9130

Pump specification
Pump Type: YLP17D3
Pump Material: Brass
Max Pressure(Bar): 100
Rated Pressure (Bar) : 80
Max Flow (L/Min) : 14L/Min
Motor specification
RPM : 2800
Power Type: Induction
Power (W/HP) : 2800W
Volt. / Freq / Replacement : 220V 50HZ
Life(hour): 500
Standard Accessories
Gun : YLG15
Lance : YLG06
Nozzles : 0°/15°/25°/40°/Soap
Gun&Lance : Material Metal
Hose Length (Meter) : 10m steel armed
Power Cord Length (Meter) : 5m
Packing: Information
Carton Meas. (LxWxH) : 815*520*570mm
G.W/N.W: 54/50 kgs



UE-7530G

Pump specification
Pump Type: YLP14
Pump Material: Brass
Max Pressure(Bar): 90
Rated Pressure (Bar) : 60
Max Flow (L/Min) : 10L/Min
Motor specification
RPM : 2800
Power Type: Induction
Power (W/HP) : 1600W
Volt. / Freq / Replacement : 220V 50HZ
Life(hour): 500
Standard Accessories
Gun : short gun
Gun&Lance : Material Metal
Hose Length (Meter) : 8m steel armed
Power Cord Length (Meter) : 5m
Packing: Information
Carton Meas. (LxWxH) : 533*353*440mm
G.W/N.W: 25.5/23kg

Home car washer



UE-4660

Motor Pump specification Real
Pump Material : Aluminum
Rated Pressure (Bar): 60
Max Pressure (Bar) : 90
Rated Flow (L/Min) : 5.5
Motor specification
Motor Material : 8040 Copper winding
Motor size (W) : 1200W
Voltages / Frequency : 220-240v/50/60HZ
Standard Accessories
Hose Type (Bar) : PVC
Hose Length (Meter): 5
Detergent Tank Kit: NO
Power Cord Type: VDE/BS
Power Cord Length (Meter) : 5
Packing Info
Load Quantity (20FT/40FT/40HQ): 958/1954/2280
Product dimensions (LxWxH): 310*302*480
Carton Meas. (LxWxH) : 335*235*375
G.W/N.W (Estimated Value) : 6.2/5.5KG



UE-5660

Motor Pump specification Real
Pump Material : Aluminum
Rated Pressure (Bar): 90
Max Pressure (Bar) : 130
Rated Flow (L/Min) : 6
Motor specification
Motor Material : 9640
Motor size (W) : 1600W
Voltages / Frequency : 220-240v/50/60HZ
Standard Accessories
Hose Type (Bar) : PVC
Hose Length (Meter): 5
Detergent Tank Kit: YES
Power Cord Type: VDE/BS
Power Cord Length (Meter) : 5
Packing Info
Load Quantity (20FT/40FT/40HQ): 284/596/688
Product dimensions (LxWxH): 394*310*809
Carton Meas. (LxWxH) : 504*342*540
G.W/N.W (Estimated Value) : 11/9.2KGS



UE-6661

Motor Pump specification Real
Pump Material : Aluminum
Rated Pressure (Bar): 110
Max Pressure (Bar) : 150
Rated Flow (L/Min) : 6.7
Motor specification
Motor Material : 9655 Copper winding
Motor size (W) : 2000W
Voltages / Frequency : 220-240v/50/60HZ
Standard Accessories
Hose Type (Bar) : PU
Hose Length (Meter): 6
Detergent Tank Kit: YES
Power Cord Type: VDE/BS
Power Cord Length (Meter) : 5
Packing Info
Load Quantity (20FT/40FT/40HQ): 270/540/576
Product dimensions (LxWxH): 416*387*911
Carton Meas. (LxWxH) : 475*375*623
G.W/N.W (Estimated Value) : 14.1/12.2KGS

high pressure washer

UE-1765



Motor	Carbon brush
Power	1200W
Voltage	220V/50Hz
Rated Pressure	60bar/870PSI
Max Pressure	90bar/1305PSI
Flow	5.5L/M 1.5GPM
Self-suction	Yes
Certification	CE/EMC/GS/PSE
Box Dimension(cm)	25x25x43
G.W.(kg)	6.2
N.W.(kg)	5.2

UE-1885AM



Motor	Carbon brush
Power	1600W
Voltage	220V/50Hz
Rated Pressure	85bar/1232.5PSI
Max Pressure	130bar/1885PSI
Flow	5.5L/M 1.5GPM
Self-suction	Yes
Certification	CE/EMC/GS
Box Dimension(cm)	38x34x58
G.W.(kg)	9.1
N.W.(kg)	8.1

UE-1896AR



Motor	Carbon brush
Power	1800W
Voltage	220V/50Hz
Rated Pressure	100bar/1450PSI
Max Pressure	150bar/2175PSI
Flow	6L/M 1.6GPM
Self-suction	Yes
Certification	CE/EMC/GS/FCC
Box Dimension(cm)	38x34x69
G.W.(kg)	10.3
N.W.(kg)	9.3

Coin-operated car washing machine



UE-02

Dimensions: 1750*750*700

materia: steel

device keys: outdoor self-locking keys.

colour: white,blue



UE-03

Dimensions: 1750*750*700

materia: steel

device keys: outdoor self-locking keys.

colour: white,blue

Tablet oscilloscope



TO1000 Series Tablet oscilloscope

Sample rate	1GSa/S
Memory depth	28Mpts
Max capture rate	130,000 wfm/s
Interface	Wi-Fi, LAN, HDMI, USB Host, USB Device, GND, DC Power, Trigger out
Screen	8 inches TFT LCD
Dimension	250*210*55mm
Battery(Optional)	8,000mAh Li-ion battery

Refrigerant recovery and filling machine



UE-900 Refrigerant recovery and filling machine

Power supply	AC220±10%	Frequency	50/60HZ
Ambient temperature	0°C- +40°C	Relative humidity	85%
External magnetic field strength	400mA/m	Compressor power	260W
Vacuum pump pumping speed	60Lmin	Refrigerant electronic weighing range	60KG
Refrigeration oil electronic weighing accuracy	± 10g	Recovery speed	150g / min
Filling speed	800g/min	External hose	2.0M
Working tank volume	12L	Machine weight	75 kg
Packing size	680 × 600 × 1160mm		



UE-300S Refrigerant recovery and filling machine

Power supply	AC220 + / 10%	frequency	50/60hz
Ambient temperature	0 to + 40 °C	relative humidity	85%
External magnetic field strength	400mA/m	compressor power	260W
Vacuum pump exhaust velocity	60Lmin	coolant electronic scale	60KG
Electronic scale of frozen oil	2kg	Cryo oil electronic scale accuracy	+ / - 2g
recovery speed	180g/min	Filling speed	800g/min
working tank capacity	12L	External hose	2.0m
total weight	75kg	Packing size	680 x 600 x 1160mm

Refrigerant recovery and filling machine



UE-AC360C

Refrigerant recovery and filling machine

Features

1. Fully-automatic function, full-automatic function of recovery, oil discharge, vacuuming, pressure holding, refrigerating oil filling, filling and purification
2. Ergonomic body design
3. Color LCD display
4. Chinese \ English operating system
5. Foldable control panel
6. Automatic testing of air-conditioning system leaks
7. Automatic discharge and filling of refrigeration oil
8. Filling pipe refrigerant automatic compensation function
9. High-pressure filling to prevent damage to the air compressor compressor

Overall information	
Refrigerant	R134a
Operating mode	automatic
Language	Chinese-English
Features	
Refrigerant recovery	Yes
Refrigerant identification	no
Refrigerant purification	Yes
Drain	automatic
Vacuum	Yes
Self-leak	automatic
Refrigerating oil filling	automatic
Fluorescent agent filling	Yes
Refrigerant filling	Yes
printer	Yes
Hybrid car (line cleaning, PAG / POE)	no
Technical specifications	
High and low pressure table	Yes
display	Color display screen
keyboard	Key membrane
compressor	3/8HP
Vacuum pump	70L/Min
Net capacity of internal refrigerant tank	10Kg
Dimensions (cm)	72.5 x 65.2 x 127.7
weight	85kg
power supply	1ph/220V/50HZ

Welded Bottle Jacks

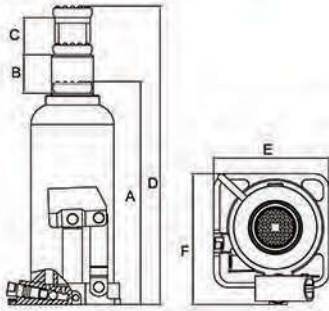

UE-TH91204X 12 Ton

Model	Fct.No.	Capacity	Min.Height (mm)	Lift Height (mm)	Adjustable Height(mm)	N.W. / G.W. (kg)	Package Size (mm)	QTY/CTN (pcs)	QTY/20'CY (pcs)	A	B	C	D	ExF
										(mm)				
UE-TH90204X	UE-TH90204X	2Ton	178	112	48	2.08 / 2.18 2.08 / 2.44	340x235x210 520x230x280	6	8790 5280	178	112	48	338	94.5x78
UE-TH90304X	UE-TH90304X	3Ton	188	115	60	2.82 / 2.97 2.82 / 3.24	375x265x225 570x230x310	6	6510 4200	188	115	60	363	108.5x87
UE-TH90404X	UE-TH90404X	4Ton	188	115	60	2.82 / 2.97 2.82 / 3.24	375x265x225 570x230x310	6	6510 4200	188	115	60	363	108.5x87
UE-TH90504X	UE-TH90504X	5Ton	207	125	70	3.72 / 3.92 3.72 / 4.32	280x265x255 355x255x290	4	4920 4496	207	125	70	402	117x97
UE-TH90604X	UE-TH90604X	6Ton	207	125	70	3.72 / 3.92 3.72 / 4.32	280x265x255 355x255x290	4	4920 4496	207	125	70	402	117x97
UE-TH90804X	UE-TH90804X	8Ton	222	145	80	4.7 / 4.84 4.7 / 4.84	295x275x260 295x275x260	4	4028 4028	222	145	80	447	124x106
UE-TH91004X	UE-TH91004X	10Ton	222	145	80	4.7 / 4.84 6 / 6.12	295x275x260 415x165x265	4	4028 3171	222	145	80	447	124x106
UE-TH91204X	UE-TH91204X	12Ton	227	150	80	6 / 6.84 6 / 6.84	410x200x310	3	2829	227	150	80	457	134.5x115
UE-TH91504X	UE-TH91504X	15Ton	227	150	80	6.94 / 7.07 6.94 / 7.07	300x180x270	2	2762	227	150	80	457	141x118
UE-TH91604X	UE-TH91604X	16Ton	227	150	80	6.94 / 7.07 8.78 / 8.98	300x180x270	2	2762	227	150	80	457	141x118
UE-TH92004X	UE-TH92004X	20Ton	235	150	60	8.78 / 8.98 17.8 / 18.05	315x185x275	2	2178	235	150	60	445	152x124
UE-TH93204	UE-TH93204	32Ton	260	160	/	17.8 / 18.05	220x200x300	1	1086	260	160	/	420	185x165
UE-TH95004	UE-TH95004	50Ton	280	170	/	25.8 / 26.05	240x220x315	1	757	280	170	/	450	207x185

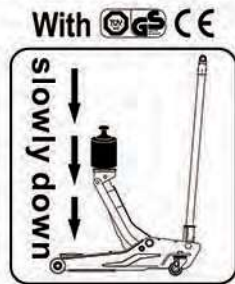
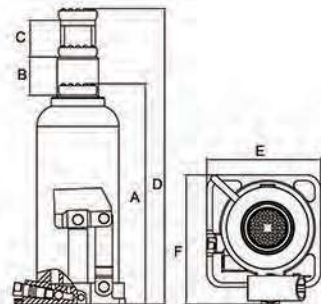

UE-TH92004 20 Ton



Model	Fct.No.	Capacity	Min.Height (mm)	Lift Height (mm)	Adjustable Height(mm)	N.W. / G.W. (kg)	Package Size (mm)	QTY/CTN (pcs)	QTY/20'CY (pcs)	A	B	C	D	ExF
										(mm)				
UE-TH90204	UE-TH90204X-GS	2Ton	168	100	48	2 / 2.11 2 / 2.36	340x235x205 520x230x280	6	9228 5280	168	108	48	316	94.5x78
UE-TH90304	UE-TH90304X-GS	3Ton	188	115	60	2.8 / 2.97 2.8 / 3.22	375x265x225 570x230x310	6	6150 4200	188	115	60	363	108.5x87
UE-TH90404	UE-TH90404X-GS	4Ton	188	115	60	2.8 / 2.97 2.8 / 3.37	375x265x225 570x230x305	6	6510 4200	185	115	60	363	108.5x87
UE-TH90504	UE-TH90504X-GS	5Ton	207	125	70	3.7 / 3.92 3.7 / 3.92	280x265x255 355x255x290	4	4920 4496	207	125	70	402	117x97
UE-TH90604	UE-TH90604X-GS	6Ton	207	125	70	3.7 / 3.92 3.7 / 4.5	280x265x245 400x230x330	4	4920 3816	207	125	70	402	117x97
UE-TH90804	UE-TH90804X-GS	8Ton	222	145	80	4.8 / 4.94 4.8 / 4.94	295x275x260	4	3960	222	145	80	447	124x106
UE-TH91004	UE-TH91004X-GS	10Ton	222	145	80	4.8 / 4.94 6 / 6.18	295x275x260	4	3960	225	145	80	450	124x106
UE-TH91204	UE-TH91204X-GS	12Ton	227	150	80	6 / 6.18 6 / 6.84	415x165x265 410x200x310	3	3156 2829	230	150	80	460	134.5x115
UE-TH91504	UE-TH91504X-GS	15Ton	227	150	80	7 / 7.13 7 / 7.13	300x180x270	2	2738	230	150	80	460	141x118
UE-TH91604	UE-TH91604X-GS	16Ton	227	150	80	7 / 7.13 8.6 / 9	305x180x270	2	2738	230	150	80	460	141x118
UE-TH92004	UE-TH92004X-GS	20Ton	235	150	60	8.6 / 9 17.8 / 18.05	315x185x275	2	2172	240	150	60	450	160x140
UE-TH93204	UE-TH93204	32Ton	260	160	/	17.8 / 18.05	220x200x300	1	1086	260	160	/	420	185x165
UE-TH95004	UE-TH95004	50Ton	280	170	/	25.8 / 26.05	240x220x315	1	757	280	170	/	450	207x185

Welded Bottle Jacks

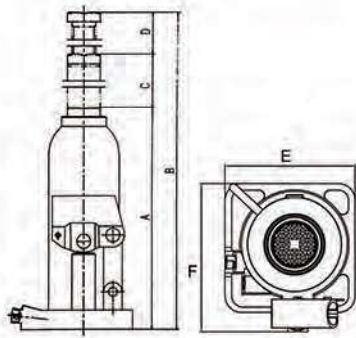

UE-TCH90804D
8 Ton

Model	Capacity	Min.Height (mm)	Lift Height (mm)	Adjustable Height(mm)	N.W. / G.W. (kg)	Package Size (mm)	QTY/CTN (pcs)	QTY/20'CY (pcs)	A	B	C	D	ExF
										(mm)			
UE-TCH90204D	2Ton	150	80	48	2.29 / 2.38	325x225x175	6	7554	150	80	48	278	90x100
UE-TCH90304D	3Ton	180	105	60	2.48 / 2.56	325x225x205	6	7062	180	105	60	345	90x100
UE-TCH90404D	4Ton	180	110	60	3.10 / 3.29	355x245x205	6	5586	180	110	60	350	100x110
UE-TCH90504D	5Ton	185	115	60	3.17 / 3.34	355x245x210	6	5508	185	115	60	360	100x110
UE-TCH90604D	6Ton	185	115	60	4.08 / 4.29	245x265x210	4	4340	185	115	60	360	110x120
UE-TCH90804D	8Ton	190	110	60	4.68 / 4.90	275x285x215	4	3820	190	110	60	360	120x125
UE-TCH91004D	10Ton	190	110	60	5.16 / 5.35	285x290x215	4	3512	190	110	60	360	120x130
UE-TCH91204D	12Ton	200	110	60	5.84 / 6.05	295x290x225	4	3120	200	120	60	380	120x135
UE-TCH91504D	15Ton	205	125	60	7.03 / 7.30	290x165x230	2	2600	205	125	60	390	130x140
UE-TCH91604D	16Ton	205	125	60	7.03 / 7.30	290x165x230	2	2600	205	125	60	390	130x140
UE-TCH92004D	20Ton	220	140	60	8.05 / 8.28	325x165x245	2	2298	220	140	60	420	140x145
UE-TCH93204D	32Ton	230	130	0	14.35 / 14.75	195x195x250	1	1304	230	130	0	360	160x175
UE-TCH95004D	50Ton	230	130	0	19.22 / 19.40	210x225x250	1	994	230	130	0	360	175x205

Hydraulic Bottle Jacks

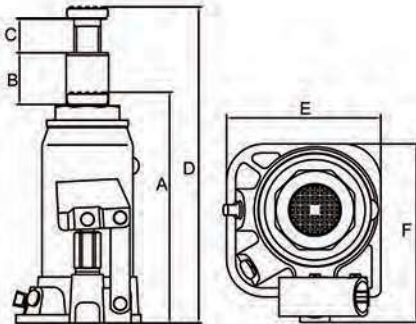

UE-T932011
32 Ton

Model	Fct.No.	Capacity	Min.Height (mm)	Lift Height (mm)	Adjustable Height(mm)	N.W. / G.W. (kg)	Package Size (mm)	QTY/CTN (pcs)	QTY/20'CY (pcs)	A	B	C	D	ExF
										(mm)				
UE-T90204DX	UE-T90204D	2Ton	148	80	48	2.3 / 2.38	315x225x175	6	8106	148	80	48	276	88x92
						2.3 / 2.64	345x330x185		7356					
UE-T90304DX	UE-T90304D	3Ton	180	110	60	3.1 / 3.18	330x240x205	6	6120	180	110	60	350	92x100
UE-T90404DX	UE-T90404D	4Ton	180	110	60	3.1 / 3.18	330x240x205	6	6120	180	110	60	350	92x100
UE-T90504DX	UE-T90504D	5Ton	185	110	60	3.95 / 4.1	260x235x220	4	4848	185	110	60	355	96x112
						3.95 / 4.39	485x255x200		4356					
UE-T90604DX	UE-T90604D	6Ton	185	110	60	3.95 / 4.1	260x235x205	4	4084	185	110	60	355	96x112
UE-T90804DX	UE-T90804D	8Ton	190	115	60	4.8 / 4.92	275x250x220	4	4848	190	115	60	365	103x118
UE-T91004DX	UE-T91004D	10Ton	195	120	60	5.61 / 5.72	280x260x225	4	3432	195	120	60	375	110x123
UE-T91204DX	UE-T91204D	12Ton	200	120	60	6.54 / 6.68	400x165x225	3	2970	200	120	60	380	116x134
UE-T91504DX	UE-T91504D	15Ton	205	125	60	7.6 / 7.7	315x170x235	2	2546	205	125	60	390	133x136
UE-T91604DX	UE-T91604D	16Ton	205	125	60	7.6 / 7.7	315x170x235	2	2546	205	125	60	390	133x136
UE-T92004DX	UE-T92004D	20Ton	217	130	60	9.75 / 9.92	330x180x250	2	1990	217	130	60	407	144x152
UE-T932011	UE-T93204DE	32Ton	230	130	/	15.9 / 16.2	230x150x255	1	1234	230	130	/	360	130x170
UE-T950011	UE-T95004DE	50Ton	240	130	/	25.4 / 25.7	270x195x255	1	778	240	130	/	270	168x210

Hydraulic Bottle Jacks

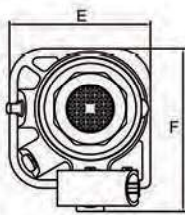
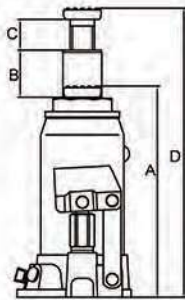

UE-T950011 50 Ton

Model	Fct.No.	Capacity	Min.Height (mm)	Lift Height (mm)	Adjustable Height(mm)	N.W. / G.W. (kg)	Package Size (mm)	QTY/CTN (pcs)	QTY/20'CY (pcs)	A	B	C	D	ExF
UE-T90204D	UE-T90204D-GS	2Ton	140	72	48	2.4 / 2.5 2.4 / 2.74	330x235x180 345x350x190	6	7692 5760	140	72	48	260	88x92
UE-T90304D	UE-T90304D-GS	3Ton	168	98	60	3.2 / 3.4 3.2 / 3.82	330x245x210 460x365x255	6	5820 4416	168	98	60	326	92x100
UE-T90404D	UE-T90404D-GS	4Ton	168	98	60	3.2 / 3.4 4.2 / 4.3	330x245x210 260x235x215	6	5820 4516	165	95	60	326	92x100
UE-T90504D	UE-T90504D-GS	5Ton	185	110	60	4.2 / 4.44 4.2 / 4.3	465x255x260 260x235x215	4	3680 4516	185	110	60	355	96x112
UE-T90604D	UE-T90604D-GS	6Ton	185	110	60	4.2 / 4.3 4.9 / 5	260x235x215 280x260x220	4	4516 3900	185	110	60	355	96x112
UE-T90804D	UE-T90804D-GS	8Ton	190	115	60	4.9 / 5 5.7 / 5.8	280x260x220 285x270x230	4	3900 3388	190	115	60	365	103x118
UE-T91004D	UE-T91004D-GS	10Ton	195	120	60	5.7 / 5.8 6.4 / 6.5	285x270x230 410x165x235	4	3388 2910	195	120	60	375	110x123
UE-T91204D	UE-T91204D-GS	12Ton	200	120	60	6.4 / 6.5 7.7 / 7.85	410x165x235 325x170x240	3	2910 2500	200	120	60	380	116x134
UE-T91504D	UE-T91504D-GS	15Ton	205	125	60	7.7 / 7.85 7.7 / 7.85	325x170x240 320x170x240	2	2500 2500	205	125	60	390	133x136
UE-T91604D	UE-T91604D-GS	16Ton	205	125	60	7.7 / 7.85 9.8 / 9.95	320x170x240 335x180x250	2	2500 2000	205	125	60	390	133x136
UE-T92004D	UE-T92004D-GS	20Ton	217	130	60	9.8 / 9.95 15.9 / 16.2	335x180x250 230x150x255	2	2000 1234	217	130	60	407	144x152
UE-T932011	UE-T93202DE	32Ton	260	130	/	15.9 / 16.2	230x150x255	1	1234	230	130	/	360	130x170
UE-T950011	UE-T95001DE	50Ton	280	130	/	25.4 / 25.7	270x195x255	1	778	240	130	/	370	168x210

Professional Welding Bottle Jack



Model	Capacity	A (mm)	B (mm)	C (mm)	D (mm)	E (mm)	F (mm)	N.W. / G.W. (kg)	Package Size (mm)	QTY/CTN (PCS)	QTY/20'CY (PCS)
UE-TH902001	2 Ton	172	88	112	372	28	103x105	3.79 / 3.95	375x290x225	6	4248
UE-TH903501	3.5 Ton	172	88	112	372	28	103x105	3.79 / 3.95	375x290x225	6	4248
UE-TH905001	5 Ton	218	110	146	474	32	110x112	4.89 / 5.05	405x300x260	6	3324
UE-TH908001	8 Ton	220	115	153	488	48	124x127.5	7.37 / 7.56	755x185x270	5	2220
UE-TH910001	10 Ton	220	115	153	488	48	124x127.5	7.37 / 7.56	755x185x270	5	2220
UE-TH912001	12 Ton	236	110	160	506	48	130x136	8.52 / 8.77	755x185x270	5	1915
UE-TH915001	15 Ton	228	113	160	508	56	140x142	9.87 / 10.12	790x190x575	5	1660
UE-TH920001	20 Ton	241	110	165	525	60	165x161	13.07 / 13.32	710x205x290	4	1260
UE-TH925001	25 Ton	240	110	157	510	65	186x174	15.07 / 15.39	590x220x305	3	1089
UE-TH930001	30 Ton	244	110	160	510	65	186x174	15.77 / 16.11	585x215x285	3	1041

Double Ram Bottle Jack

Complies with
ASME
Safety Standards



Feature:

- Welded construction NO LEAK.
- Inner safety valve prevents the user to adjust the system.
- Prevent rust with ENP (electroless nickel plating) ram piston, make it smooth, bright, and long life.
- Double seals in the pump help to prevent oil leaks.
- Longer life than normal screw connection jack due to smooth bearing surfaces and close tolerances.

Patent No.: ZL200830350236.3



Model	Capacity	Min. Height (mm)	Max. Height (mm)	Base Place	Product Size (mm)	Package Size (mm)	N.W. / G.W. (kg)	QTY/CTN (PCS)	QTY/20'CY (PCS)
UE-TH810002	10 Ton	125	225	/	180x180x140	560x390x180	7.7 / 8	6	2100
UE-TH810003	10 Ton	182	375	Ø123	158x126x182	550x380x160	8.8 / 9.1	3	1887

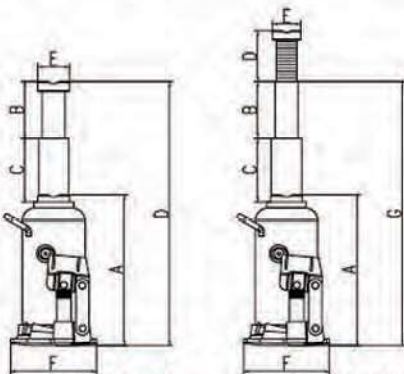

Chrome Plated

Complies with
ASME
Safety Standards



Model	Capacity	A (mm)	B (mm)	C (mm)	D (mm)	E (mm)	F (mm)	G (mm)	Product Size (mm)	Package Size (mm)	N.W. / G.W. (kg)	QTY/CTN (PCS)	QTY/20'CY (PCS)
UE-TH804001	4 Ton	270	180	170	612	35	124x127.5	/	128x124x265	435x300x320	7.1 / 7.5	6	2238
UE-TH805001	5 Ton	222	146	138	500	41	130x136	/	136x130x230	450x320x275	7.5 / 7.8	6	2148
UE-TH810001	10 Ton	210	120	118	78	48	165x161	442	165x161x208	760x210x265	10.7 / 11	4	1524
UE-TH812001	12 Ton	236	138	128	98	56	186x174.5	498	186x175x230	570x220x290	14.9 / 15.2	3	1104

Double Ram Bottle Jacks



- Dual-stage, steel hardened rams allow for longer travel. Lower retracted heights and higher extended heights. Heat treated saddle provides generous lifting area and secure grip.
- A wide, rugged base provides stability and strength. Safety bypass valves prevent overloading.

Complies with
ASME
Safety Standards



Model	Capacity	Min. Height (mm)	Lifting Height (mm)	Adjustable Height (mm)	N.W. / G.W. (kg)	Package Size (mm)	QTY/CTN (PCS)	QTY/20'CY (PCS)
UE-TF0608	6 Ton	215	220	62	6.1 / 6.4	330x330x245	4	2800
UE-TF0808	8 Ton	227	162	80	7.3 / 7.6	330x185x305	2	1540
UE-TF1008	10Ton	200	232	87	9.2 / 9.5	355x195x255	2	1800
UE-TF1008G	10Ton	223	284	89	10.2 / 10.6	355x195x280	2	1600

Welded Bottle Jacks



Double Ram



Model	Capacity	Min. Height (mm)	Lifting Height (mm)	Adjustable Height (mm)	Product Size (mm)	N.W. / G.W. (kg)	Package Size (mm)	QTY/CTN (PCS)	QTY/20'CY (PCS)
UE-TH80202X	2 Ton	170	210	/	87X108.5X170	2.6 / 2.7	360x255x200	6	7200
UE-TH80402X	4 Ton	170	190	60	97X117X170	3.36 / 3.5	280x250x200	4	5572
UE-TH80602X	6 Ton	170	200	60	115X134.5X170	4.7 / 4.85	310x280x200	4	4040
UE-TH80802X	8 Ton	170	200	60	115X134.5X170	4.7 / 4.85	310x280x200	4	4040
UE-TH81002X	10 Ton	180	210	60	124X152X180	7.65 / 7.8	315x185x210	2	2514

Pneumatic Hydraulic Bottle Jacks



UE-Q05002
5 Ton



UE-TQ12002
12 Ton



UE-TQ20002
20 Ton



UE-Q30002
30 Ton



UE-Q35002
35 Ton

CE



UE-Q50002
50 Ton



Model	Capacity	Min. Height (mm)	Lifting Height (mm)	Adjustable Height (mm)	Max. Height (mm)	N.W. / G.W. (kg)	Package Size (mm)	QTY/20'CY (PCS)
UE-Q05002	5 Ton	210	140	80	430	6 / 7	170x200x230	2300
UE-TQ12002	12 Ton	263	170	82	515	12 / 13	280x170x295	1292
UE-TQ20002	20 Ton	267	165	82	515	16 / 17	300x190x285	988
UE-Q30002	30 Ton	250	150	/	405	21 / 22	290x220x270	690
UE-Q35002	35 Ton	250	150	/	405	21 / 22	290x220x270	690
UE-Q50002	50 Ton	290	160	/	450	34 / 36	460x280x310	455

Professional Support Jack



UE-SJ05
5 Ton



UE-SJ10
10 Ton



UE-SJ15
15 Ton



UE-SJ20
20 Ton



UE-SJ25
25 Ton

Model	UE-SJ05	UE-SJ10	UE-SJ15	UE-SJ20	UE-SJ25
Capacity	5 Ton	10 Ton	15 Ton	20 Ton	25 Ton
Min. Height (mm)	240	295	358	405	425
Lifting Height (mm)	100	160	190	230	246
Max. Height (mm)	340	450	556	632	675
N.W. / G.W. (kg)	4.2 / 4.6	7.1 / 7.7	10.5 / 11.2	15.6 / 17	18.3 / 19
Package Size (mm)	605x315x305	520x350x361	390x380x420	430x230x470	227x227x480
QTY/CTN (PCS)	8	6	4	2	1
QTY/20'CY (PCS)	3648	2178	1500	988	884

Mechanical Screw Jack



UE-B1003B
3.2 Ton



UE-B1005B
5 Ton



UE-B1008B
8 Ton



UE-B1010B
10 Ton



UE-B1016B
16 Ton



UE-B1020B
20 Ton



UE-B1025B
25 Ton



UE-B1032B
32 Ton



A Mechanical Screw Jack has a compact structure, small volume, is light weight and easy to carry. Screw Jacks are widely used in factories, warehouses, bridges, shipyards, fabrications and construction industries.



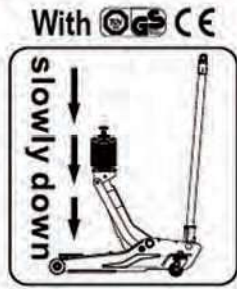

Model	UE-B1003B	UE-B1005B	UE-B1008B	UE-B1010B	UE-B1016B	UE-B1020B	UE-B1025B	UE-B1032B
Capacity	3.2Ton	5Ton	8Ton	10Ton	16Ton	20Ton	25Ton	32Ton
Min.Height(mm)	220	250	260	280	320	325	275	395
Max.Height(mm)	330	380	400	430	500	505	405	595
N.W./G.W.(Kg)	17.2/18	20.4/21	24.8/25.5	21.6/22.5	32.1/33	32.7/33.5	28.5/29.5	34.6/35.5
Package Size(mm)	535x255x160	550x287x180	550x287x180	510x310x190	555x355x210	555x355x210	555x355x210	445x420x235
QTY/CTN(PCS)	4	4	4	3	3	3	3	2
QTY/20'CY(PCS)	3732	3200	2632	2238	1527	1503	1707	946

Hydraulic Trolley Jacks



   UE-TA820011



Model	Capacity	Min. Height (mm)	Max. Height (mm)	N.W. / G.W. (kg)		Product Size (mm)	Package Size (mm)	QTY/20'CY (PCS)
				 Color Box	 Blow Case			
UE-TA820011	2 Ton	140	285	5.6 / 6.2	5.6 / 6.5	390x195x140	400x205x145 / 415x220x150	2600 / 2200
UE-TA82008	1.5 / 2 Ton	130	300	6.8 / 7.5	6.8 / 7.8	425x190x130	430x200x135 / 445x225x145	2500 / 2050
UE-T820014	2 Ton	135	330	7.3 / 7.9	7.3 / 8.4	465x195x135	470x205x145 / 480x225x150	2050 / 1700
UE-T820050	2 Ton	135	340	8.7 / 9.4	8.7 / 9.9	447x196x135	460x215x145 / 495x235x155	1950 / 1498
UE-T820050R	2 Ton	135	340	8.8 / 9.5	8.8 / 10.2	447x196x145	460x215x160 / 495x235x167	1820 / 1391
UE-T82000H	2 Ton	135 / 150	342 / 357	9.3 / 10.34	/	470x196x135	490x240x145	1600
UE-T82000D	2 Ton	130	340	9.4 / 9.7	9.4 / 11	469x206x130	480x230x163 / 500x235x160	1670 / 1390
UE-T82004	2 Ton	130	350	10.1 / 10.9	10.1 / 11.6	492x218x130	500x230x140 / 525x252x150	1584 / 1416





UE-T825051

 
Complies with **ASME** Safety Standards

NEW PRODUCT



    UE-TA820037

Model	Capacity	Min. Height (mm)	Max. Height (mm)	N.W. / G.W. (kg)		Product Size (mm)	Package Size (mm)	QTY/20'CY (PCS)
				 Color Box	 Blow Case			
UE-TA82001	2 Ton	85	330	10.5 / 11.5	10.5 / 12	534x216x135	548x230x160 / 583x251x156	1450 / 1300
UE-T82007	2 Ton	130	350	11 / 11.7	11 / 12.52	493x222x144	495x235x165	1430
UE-TA820037	2 Ton	80	380	11.4 / 12	11.4 / 13.2	566x206x130	610x275x145	1400
UE-T825051	2.5 Ton	85	380	12.6 / 13.6	/	569x214x130	613x265x150	1080
UE-T825010	2 Ton	89	359	14.2 / 15.2	14.2 / 16.1	556x234x140 / 556x234x150	610x275x160 / 590x260x160	1008 / 1000
UE-T825010R	2 / 2.5 Ton	89	359	14.2 / 15.2	14.2 / 16.1	556x234x140 / 556x234x150	610x275x160 / 590x260x160	1008 / 1000

Hydraulic Trolley Jacks

With GS CE



Model	Capacity	Min. Height (mm)	Max. Height (mm)	N.W. / G.W. (kg)		Product Size (mm)	Package Size (mm)	QTY/20'CY (PCS)
				Color Box	Blow Case			
UE-TA82005	2 Ton	135	385	10.3 / 11.3		520x195x135	530x205x145	1486
UE-T82003	2 Ton	130	375	11.8 / 12.3	11.8 / 13.2	531x223x132	555x250x160 / 580x250x160	1288 / 1188
UE-T82253	2.25 Ton	130	375	11.8 / 12.3	11.8 / 13.2	531x223x132	555x250x160 / 570x245x160	1288 / 1196
UE-T830013	3 Ton	135	380	13.6 / 14.8		531x225x135	560x250x160	1288
UE-T830020	3 Ton	135	400	16.4 / 17		592x240x146	630x280x165	1008
UE-T83003C	3 Ton	130	410	19 / 20.4		625x242x158	675x285x180	768
UE-T83006B	2.5 / 3 Ton	150	530	19.3 / 21		625x242x158	675x285x180	768
UE-T83006F	2.5 / 3 Ton	150	530	19.3 / 21.2		625x242x158	675x285x180	768



Model	Capacity	Min. Height (mm)	Max. Height (mm)	Product Size (mm)	N.W. / G.W. (kg)	Package Size (mm)	QTY/20'CY (PCS)
UE-TZ822501	2.25 Ton	130	465	572x328x175	27 / 28.5	615x375x200	540
UE-T825021	2.5 Ton	140	520	662x342x180	34.1 / 36.1	733x380x225	450
UE-T830025	3 Ton	130	465	572x328x175	27.4 / 28.9	620x380x215	540
UE-T83000F	3 Ton	145	490	630x342x185	33 / 34.7	675x380x200	528
UE-T830022	3 Ton	140	520	662x344x180	35 / 36.3	733x380x225	528

Trolley Jack Combo Set

2 Ton Trolley Jack (UE-TA820014)
Folding Creeper (UE-H6454B)
Jack Stands (UE-T42002X)

Complies with
ASME
 Safety Standards



N.W.(kg): 17.6 kgs
 G.W.(kg): 19 kgs
 Package Size: 485x375x400 mm
 QTY/20'CY: 330 PCS

2 Ton Trolley Jack (UE-T820050)
Wheel Chocks (UE-F3553)
Work Gloves (UE-Y9007)
Knee Pad (UE-L7001)



N.W.(kg): 9.5 kgs
 G.W.(kg): 10.96 kgs
 Package Size: 505x235x160 mm
 QTY/20'CY: 1498 PCS

2 Ton Trolley Jack (UE-T820050)
Knock Down Creeper (UE-H6454B)
Wheel Chocks (UE-F3553)
2 Ton Jack Stand (UE-T42002)
14" Lug Wrench
Size: 17/19/21/23 mm (UE-TRX31101)



N.W.(kg): 20.8 kgs
 G.W.(kg): 22.7 kgs
 Package Size: 505x390x385 mm
 QTY/20'CY: 396 PCS

2 Ton Trolley Jack (UE-T820050)
2 Ton Jack Stand (UE-T42004)
Wheel Chock (UE-F3553)
Knock Down Creeper (UE-H6454B)
Oil pan (UE-Y2006YH)
14" Lug Wrench
Size: 17/19/21/23 mm (UE-X31101)
Magnetic Dish (UE-Y60.0001)
Oilfilter Wrench (UE-Y032602)



N.W.(kg): 21 kgs
 G.W.(kg): 23.5 kgs
 Package Size: 480x390x395 mm
 QTY/20'CY: 330 PCS

Combination Kit

2 Ton Trolley Jack (UE-T820050)
Folding Creeper (UE-H6454B)
Wheel Chocks (UE-F3553)
Knee Pad (UE-L7001)

N.W.(kg): 15.4 kgs
 G.W.(kg): 17.2 kgs
 Package Size: 490x385x310 mm
 QTY/20'CY: 462 PCS



2 Ton Combination Kit

2 Ton Trolley Jack (UE-T820050)
2 Ton Foldable Jack Stand (UE-T42004)
Wheel Chocks (UE-F3553)

N.W.(kg): 12.6 kgs
 G.W.(kg): 14.5 kgs
 Package Size: 520x300x165 mm
 QTY/20'CY: 1064 PCS



2 Ton Service Jack & Stands Combo

2 Ton Trolley Jack (UE-T820050)
3 Ton Jack Stands (UE-T41507)
Wheel Chocks (UE-F3553)
14" Lug Wrench (UE-X31101)

N.W.(kg): 15.6 kgs
 G.W.(kg): 17.2 kgs
 Package Size: 470x290x410 mm
 QTY/20'CY: 480 PCS



Hydraulic Garage Jack

Special Quality Design

Polished and treated cylinder rams use high performance seals.



Polished inner cylinder walls extend the life of the seals to minimize abrasion and wear.



With



2.5 TON

3 TON

Complies with **ASME**
Safety Standards

UE-TZ830018

Low Profile 85 mm
Min. Height

Model	Capacity	Min. Height (mm)	Max. Height (mm)	Product Size (mm)	N.W. / G.W. (kg)	Package Size (mm)	QTY/20'CY (PCS)
UE-TZ830018	2.5 / 3 Ton	87	455	640x342x175	33 / 34.6	700x390x215	480
UE-T830018Z	3 Ton	95	465	684x340x160	35.5 / 37.3	735x385x225	450
UE-T830023	3 Ton	130	465	630x328x165	28.7 / 30.2	675x380x213	528
UE-T83502	3 / 3.5 Ton	145	500	685x346x180	37.2 / 38.4	740x380x205	495

Professional Garage Jack

Special Quality Design

Polished and treated cylinder rams use high performance seals.



Polished inner cylinder walls extend the life of the seals to minimize abrasion and wear.



Low Profile

2 TON



With



SUV High Lifting

3 TON



Patent No.: ZL200910182545.8
U.S. Patent No.: US8,297,595B2

2 TON / 3 TON

UE-T830027

FOLDABLE LIFTING ARM

Low Profile 98 mm
Min. Height

Complies with **ASME**
Safety Standards

Model	Capacity	Min. Height (mm)	Max. Height (mm)	Product Size (mm)	N.W. / G.W. (kg)	Package Size (mm)	QTY/20'CY (PCS)
UE-T830027	2 / 3 Ton	98 / 245	580 / 585	795x335x170	43.5 / 45.3	860x400x200	374
UE-TZ830026	2.5 Ton	80	508	722x328x150	34.1 / 36	780x400x185	470
UE-T83508	3 / 3.5 Ton	98	535	760x345x170	43.3 / 45.1	815x400x200	385

Professional Garage Jack

Super Height 615mm
Max. Height



2 TON

Complies with
ASME
Safety Standards

UE-TZ820051

Low Profile 70mm
Min. Height

Model	Capacity	Min. Height (mm)	Max. Height (mm)	Product Size (mm)	N.W. / G.W. (kg)	Package Size (mm)	QTY/20'CY (PCS)
UE-TZ820051	2 Ton	75	615	850x380x160	47.7 / 52	900x430x175	323
UE-T84007	4 Ton	98	508	726x342x170	43.1 / 45.6	790x400x200	385

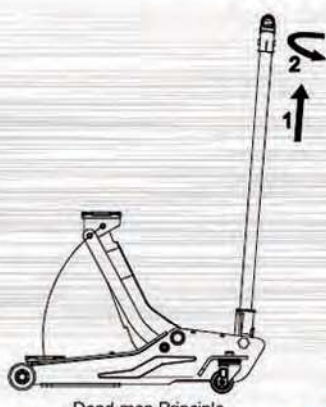
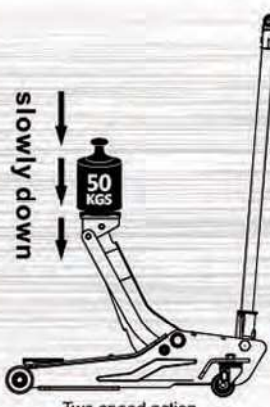

Foot Pedal



Magnetic Tool Panel

3 TON

UE-TZA830003

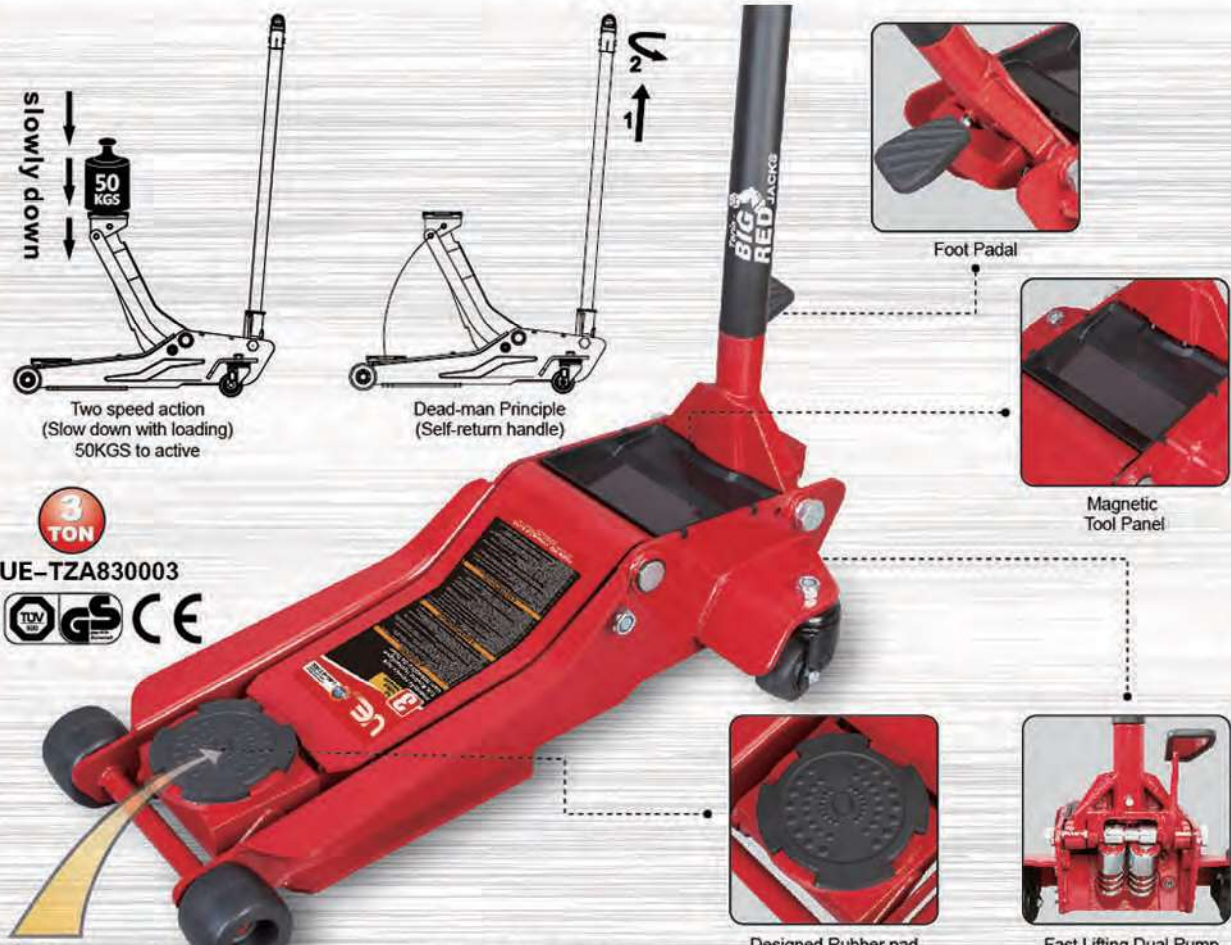

Low Profile 95mm
Min. Height

Nylon Wheel



Designed Rubber pad (Φ130mm)



Fast Lifting Dual Pump

Model	Capacity	Min Height (mm)	Max Height (mm)	Product Size (mm)	N.W. / G.W. (kg)	Package Size (mm)	QTY/20'CY (PCS)
UE-TZA830003	3.TON	95	505	720x308x1195	41 / 43	820x380x190	400

YELLOW JACKET



3 TON

SUPER-DUTY JACK



LIFTS UP TO
75% FASTER



INDUSTRY LEADING
LIFTING RANGE:
4" TO 23"

Patent No.:
ZL201630443762.9



**DESIGNED TO LASTS 10 TIMES LONGER THAN TRADITIONAL JACKS
EXTEND LIFT UP TO 5,000+ LIFTING CYCLES**

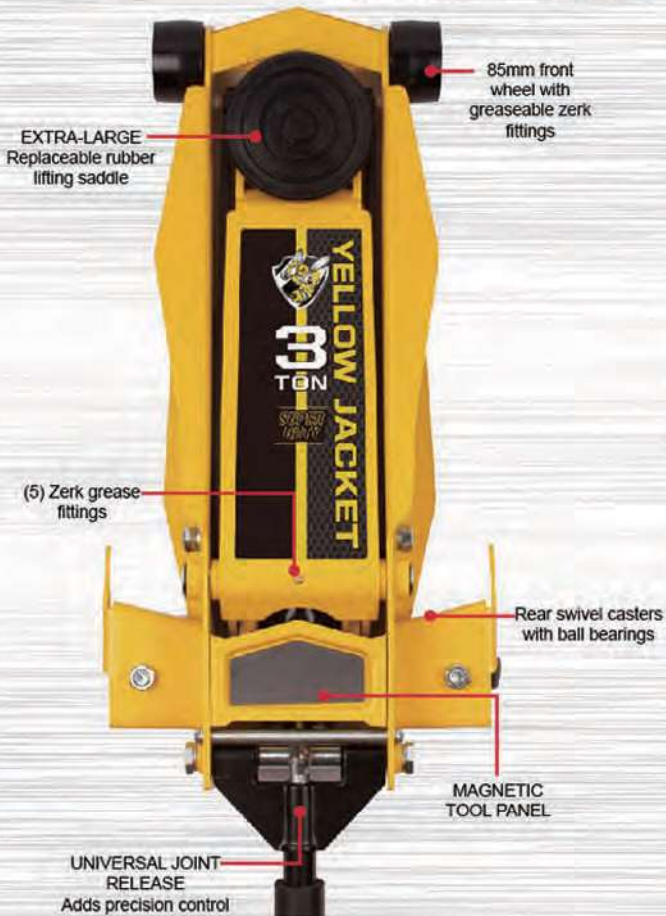

Polyurethane Seals
Made to resist higher abrasion, cut and tear resistance making it last longer than traditional rubber O-rings

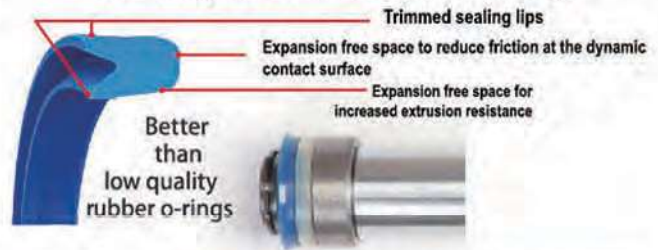

LIFTS UP TO 75% FASTER
Double pump design reaches max. Rise height in under 5 pumps



Model	Capacity	Min Height (mm)	Max Height (mm)	Product Size (mm)	N.W. / G.W. (kg)	Package Size (mm)	QTY/20'CY (PCS)
UE-T830008	3 TON	100	585	846x398x168	51.5 / 55.9	900x455x185	300

Professional Garage Jack

Features:

- Professional stronger construction
- Compact and space-saving
- Protector, top saddle protection for safer lifting
- Polyamide wheels - for quietly positioning
- Long life using more than 1000 times
- 3 years guarantee

Products on this page are covered by international patents

Patent No.: ZL201110232918.5
ZL201210130146.9

Special Quality Design

Polished inner cylinder walls extend the life of the seals to minimize abrasion and wear.



Polished and treated pump cylinder pistons use high performance seals.



Nylon Wheels



DESIGNED TO LASTS 10 TIMES LONGER THAN TRADITIONAL JACKS
EXTEND LIFT UP TO 3,000+ LIFTING CYCLES



UE-15005

Model	Capacity	Min. Height (mm)	Max. Height (mm)	Net Weight (kg)	Gross Weight (kg)	Package Size (mm)	QTY/20'CY (PCS)
UE-15005	1.5 Ton	135	855	50	54	1135x490x220	220

Rubber Jack-Pad



For Trolley Jack

Model	UE-Y8011
Diameter(mm)	100
Thickness(mm)	28
Package Size(mm)	530x360x225
QTY/CTN(PCS)	100



Applied Model: T820033 series, T820033X series, T82000D, T82000R, T82000CF, T82004, T82004C

Model	UE-T820033E-2
Diameter(mm)	39
Thickness(mm)	15
Package Size(mm)	400x165x200
QTY/CTN(PCS)	100

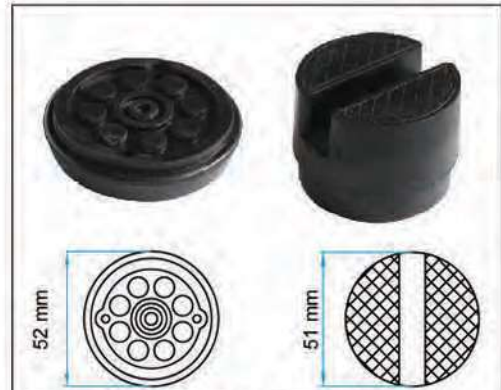

Applied Model: T825010 series, T825010C series, T820037, T830020

Model	UE-T825010CE-2	UE-T825010-9
Diameter(mm)	52	51
Thickness(mm)	13	37
Package Size(mm)	430x180x175	310x310x310
QTY/CTN(PCS)	100	60



Applied Model: T83006, T83006B, T83006C, T83006F

Model	UE-T83006FE-3
Diameter(mm)	44
Thickness(mm)	15
Package Size(mm)	410x170x200
QTY/CTN(PCS)	100



Applied Model: T830008

Model	UE-T830021-3
Diameter(mm)	137
Thickness(mm)	20
Package Size(mm)	400x280x320
QTY/CTN(PCS)	90



Applied Model: T830023, T830025

Model	UE-T830025-8
Diameter(mm)	96.5
Thickness(mm)	23
Package Size(mm)	315x315x365
QTY/CTN(PCS)	135

Nylon Wheel



Applied Model: T83502 series, T830021 series, T83000F, T830022, T830021Q, T830021B, T83000E

Model	UE-T830021-4
Diameter(mm)	88
Thickness(mm)	46
Materials	PA66



Applied Model: T83508 series, T830025 series, T830018Z series, T84008, T84007, T830023 series

Model	UE-T830023B-1
Diameter(mm)	80
Thickness(mm)	47
Materials	PA66

Low Profile Garage Jack

Special Quality Design

- Polished and treated cylinder rams use high performance seals.

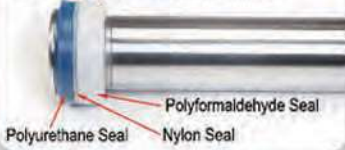

- Polished inner cylinder walls extend the life of the seals to minimize abrasion and wear.



- Polished and treated pump cylinder pistons use high performance seals.



Products on this page are covered by international patents

Patent No.:

ZL201220168382.5 ZL201220319166.6
 ZL201210130197.1 ZL200920283713.8
 ZL201210130146.9 ZL201210072632.X
 ZL201030128868.2



• PU Material Front Wheel



• Nylon rear wheel with ball bearing



• Foot pedal for quick lifting saddle to load



• Magnetic tools tray for carrying objects



• Slowly down with loading

Model	Capacity	Min. Height (mm)	Max. Height (mm)	Product Size (mm)	N.W. / G.W. (kg)	Package Size (mm)	QTY/20'CY (PCS)
UE-T820031	2 Ton	70	500	785x280x214	40 / 43	935x430x220	300
UE-T820031DS	2 Ton	70	500	822x360x214	43 / 46	985x460x220	270
UE-T820028	2 Ton	76	510	1006x365x136	45 / 48	1065x450x215	260

Aluminum Floor Jack



Model	UE-T43004L	UE-T430010L
Capacity	3 Ton	3 Ton
Min. Height	272 mm	268
Max. Height	397 mm	393
Product Size	190x173x272 mm	160x143x245
Package Size	800x290x180 mm	680x380x210
N.W./G.W.	4.5 / 4.63 (kg/pair)	4.2 / 4.6
QTY/CTN	6 pairs	6 pairs
QTY/20'CY	3522 PCS	2640 pairs

Model	UE-T815012L
Capacity	1.25/1.5 Ton
Min. Height	85 mm
Max. Height	375 mm
Product Size	555x250x150 mm
Package Size	595x295x180 mm
N.W./G.W.	12.2 / 13.5 kg
QTY/20'CY	950 PCS



UE-T815012L



3 TON
UE-T430010L



T830003L

UE-T830003L
Complies with
ASME
Safety Standards

Aluminum Racing Jack



Easy Carrying



Fast Lifting Dual Pump



Low Profile **98 mm** Min. Height

Model	Capacity	Min. Height(mm)	Max. Height(mm)	Product Size(mm)	Package Size(mm)	N.W./G.W.(kg)	QTY/20'CY (PCS)
UE-T815013L	1.5 Ton	85	365	573X253X137	620X295X180	12 / 13.3	790
UE-T830003L	2.5 / 3 Ton	98	480	730X320X180	790X385X220	24.4 / 26.1	420

Aluminum / Steel Floor Jack

Model	UE-T815016L
Capacity	1.5 Ton
Min. Height	90 mm
Max. Height	358 mm
Package Size	595x295x180
N.W./G.W.	14.3 / 15.6
QTY/20'CY	950 PCS



Fast Lifting Dual Pump



1.5 TON
UE-T815016L

With TUV GS CE

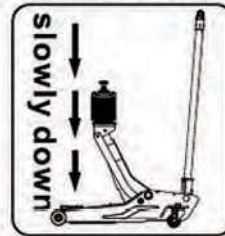

- Fast action with dual lifting pistons
- Rubber padded saddle rotates 360 degree to provide protection and stability
- Durable, light-weight steel and aluminum construction

Heavy Duty Long Floor Jack

- Ideal for lifting heavy trucks, buses, agriculture and constructions equipments.
- Heavy duty steel frame for maximum durability.
- Long frame for easy access lift point.
- Safety-overload system.
- Additional foot pedal control provides quick set-up and rise.
- Oversized swivel casters for easy mobility.



10 TON
UE-100001

15 TON
UE-A150001-1
UE-A150001-K(Quick Lift)

20 TON
UE-A200001-1
UE-A200001-K(Quick Lift)



W/C Wooden Box

Model	Capacity	Min. Height (mm)	Max. Height (mm)	Product Size (mm)	N.W. / G.W. (kg)	Package Size (mm)	QTY/20'CY (PCS)
UE-20003	2 Ton	140	800	1184X435X188	58 / 64	1275x480x230	200
UE-30001	3 Ton	130	600	1312X400X188	65 / 71.5	1465x435x215	180
UE-30002	3 Ton	140	665	1100X436X186	54 / 60	1185x480x230	200
UE-50001	5 Ton	160	560	1412X418X186	85 / 100	1618x475x350	90
UE-100001	10 Ton	160	560	1540X486X255	129 / 150	1710x525x395	65
UE-A150001-1	15 Ton	220	680	1550X560X305	165 / 180	1703x523x384	95
UE-A150001-K	15 Ton	220	680	1550X560X305	165 / 180	1650X370X430	95
UE-A200001-1	20 Ton	220	680	1550X560X305	215 / 230	1650X370X430	75
UE-A200001-K	20 Ton	220	680	1550X560X305	215 / 230	1650X370X430	75

Pneumatic Jack

Model	UE-A25-2A	UE-A40-2A	UE-A50-2A	UE-A80-2A
Capacity	25T/10T	40T/20T	50T/25T	80T/50T
Air Pressure	0.9-1.2Mpa	0.9-1.2Mpa	0.9-1.2Mpa	0.9-1.2Mpa
Min. Height (mm)	185	190	215	230
Lifting Height	25T:97mm 10T:95mm	40T:106mm 20T:88mm	50T:115mm 25T:114mm	80T:111mm 50T:102mm
Extension Height (mm)	75+45	75+45	75+45	75+45
N.W. / G.W. (kg)	53 / 59	62 / 70	73 / 80	106 / 115
Package Size (mm)	840x300x270	840x300x270	840x290x230	980x390x320
Handle Box (mm)	1390x280x110	1390x280x110	1390x280x110	1390x280x110
QTY / 20'CY (PCS)	160	160	160	150

PROFESSIONAL PNEUMATIC 

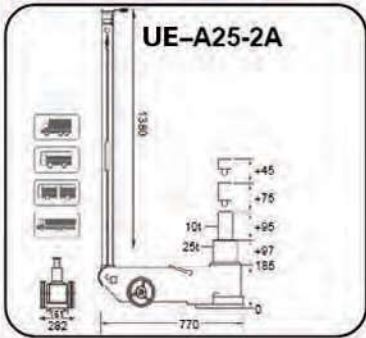

Model	UE-A30-2AL / UE-A40-2AL	UE-A40-3AL	UE-A50-3A	UE-A60-3AL	UE-A60-4A
Capacity	30T/15T 40T/20T	40T/20T/10T	50T/25T/10T	60T/40T/20T	60T/40T/22T/11T
Air Pressure	0.9-1.2Mpa	0.9-1.2Mpa	0.9-1.2Mpa	0.9-1.2Mpa	0.9-1.2Mpa
Min. Height (mm)	170 / 170	125	160	150	150
Lifting Height	30T:86mm 40T:88mm 15T:83mm 20T:81mm	40T:57mm 20T:49mm 10T:53mm	50T:62mm 25T:61mm 10T:69mm	60T:57mm 40T:59mm 20T:61mm	60T:57mm 40T:60mm 22T:61mm 11T:68mm
Extension Height (mm)	75+45	75+45	75+45	75+45	75+45
N.W. / G.W. (kg)	53 / 56	44 / 50	57 / 60	64 / 67	62 / 65
Package Size (mm)	620x300x250	370x330x220	890x290x230	1000x300x240	1000x300x240
Handle Box (mm)	1390x280x110	1390x280x110	1390x280x110	1390x280x110	1390x280x110
QTY / 20'CY (PCS)	190	160	160	160	160

PROFESSIONAL PNEUMATIC

UE-A30-2AL 30Ton / 15Ton
UE-A40-2AL 40Ton / 20Ton

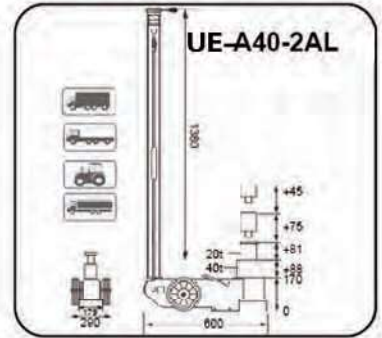
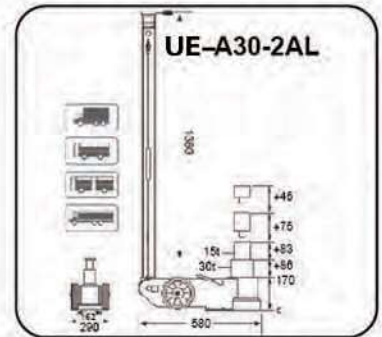



Pneumatic Jack



UE-TQ22001
22 Ton



UE-TQ35001
(UE-A1350)
35 Ton

Model	Capacity	Min. Height (mm)	Max. Height (mm)	Ram Lift (mm)	Screw Extend (mm)	Air Pressure (Mpa)	N.W. / G.W. (kg)	Package Size (mm)	QTY/20'CY (PCS)
UE-TQ22001	22 Ton	220	435	110	105	0.7 ~ 1.2	45 / 47	675x390x260	352
UE-TQ35001 (A1350)	35 Ton	250	495	130	115	0.7 ~ 1.2	46 / 48	675x390x260	350

Hydraulic Portable Body Repair Kits

Blow Mold Case

UE-T710015
10 Ton



NOTE: T710015
Includes: Hand pump, hose, cylinder ram, spreader ram, rubber head, ram toe, cleft cap, V cap, plunge toe, quincunx, chain

Model	UE-T710015
Capacity	10 Ton
Package Size (mm)	750x480x265
N.W. / G.W. (kg)	36 / 41.5
QTY / 20'CY (PCS)	388



Hydraulic Portable Body Repair Kits

Model	UE-A0204-1	
Capacity	20 Ton	
Lifting Height (mm)	125	
Min. Ram Height (mm)	278	
Package Size (mm)	Fig.1# 760x330x260	Fig.2# 690x400x130
N.W. / G.W. (kg)	Fig.1# 25.5 / 33	Fig.2# 26.5 / 34
QTY / 20'CY (PCS)	280	

UE-A0204-1 20 Ton

Metal Case



UE-T70402S 4 Ton

Model	UE-T70402S
Capacity	4 Ton
Min. Ram Height (mm)	330
Ram Lifting Height (mm)	120
N.W. (kg)	14.5
G.W. (kg)	17.5
Package Size	620X335X195
QTY / 20'CY (PCS)	660



UE-T71002L 10 Ton

Model	UE-T71002L
Capacity	10 Ton
Min. Ram Height (mm)	470
Ram Lifting Height (mm)	150
N.W. (kg)	27
G.W. (kg)	34
Package Size	990X440X220
QTY / 20'CY (PCS)	270



Hydraulic Ram & Hand Pump



UE-B0.6L
0.6L

UE-B1L
1L

UE-B2L
2L

Model	UE-B0.6L	UE-B1L	UE-B2L
Pressure Capacity	63 Mpa	63 Mpa	63 Mpa
Oil Capacity (high pressure)	2.6 ml/time	3 ml/time	3 ml/time
Oil Capacity (low pressure)	11.5 ml/time	20 ml/time	20 ml/time
Total Oil Capacity	0.6 L	1.0 L	1.9 L
Package Size (mm)	590x115x155	700x140x170	710x150x190
N.W. / G.W. (kg)	6 / 6.7	9 / 10	13 / 14.1
QTY / 20'CY (PCS)	2900	2000	1400



UE-B2005
5 Ton



UE-B2010
10 Ton



UE-B2015
15 Ton



UE-B2020
20 Ton



UE-B2030
30 Ton



UE-B2050
50 Ton



UE-B2075
75 Ton



UE-B2100
100 Ton



UE-B2150
150 Ton

Model	UE-B2005	UE-B2010	UE-B2015	UE-B2020	UE-B2030	UE-B2050	UE-B2075	UE-B2100	UE-B2150
Capacity	5 Ton	10 Ton	15 Ton	20 Ton	30 Ton	50 Ton	75 Ton	100 Ton	150 Ton
Min. Height (mm)	40	45	50	60	65	75	85	95	118
Lift Height (mm)	9	11	13	17	17	19	21	25	30
Product Size (mm)	63x44x40	78x56x45	92x68x50	104x80x60	125x100x65	153x125x75	186x155x85	206x175x95	247x215x118
Work Pressure (Mpa)	51	51.9	60.1	59.1	58.5	62.5	59.9	63.7	61.2
N.W. / G.W. (kg)	0.75 / 1.2	1.3 / 1.8	2 / 2.5	3.1 / 3.9	5 / 5.8	8.8 / 9.7	15.3 / 16.1	21 / 23	40 / 41.5
Package Size (mm)	70x50x43	85x65x50	102x77x55	110x85x65	130x105x70	160x130x80	190x160x90	215x180x100	250x220x120
QTY / 20'CY (PCS)	16000	11000	8000	5100	3400	2000	1200	890	480

Hand Operated Pump



Pressure Gauge

Complies with
ASME
Safety Standards

UE-T71001B1
10 Ton



Pressure Gauge

UE-T70401B1
4 Ton

Model	Capacity	N.W. / G.W. (kg)	Package Size (mm)	QTY/20'CY (PCS)
UE-T70401B1	4 Ton	6.2 / 6.7	555x170x180	1584
UE-T71001B1	10 Ton	7.2 / 7.7	695x170x180	1248

Pull-back Ram



UE-K1220
20 Ton



UE-K1210
10 Ton



UE-K1202
2 Ton



UE-K1205
5 Ton

Model	Capacity	PCS / CTN	Max. Length (mm)	Stroke (mm)	N.W. / G.W. Kgs / CTN	Package Size (mm)	QTY/20'CY (PCS)
UE-K1202	2 Ton	6	575	120	22 / 24	600x290x230	4200
UE-K1205	5 Ton	6	665	130	33 / 35	690x290x230	4000
UE-K1210	10 Ton	4	715	130	32 / 34	680x340x210	2000
UE-K1220	20 Ton	1	980	200	20 / 21	930x205x135	850

Portable Hydraulic Repair Ram Kit



Model	UE-K02001-1 (Metal Case)
N.W. / G.W. (kg)	23 / 24
Package Size (mm)	650x450x110
QTY / 20'CY (PCS)	750
Model	UE-K02001-S (Blow Mold Case)
N.W. / G.W. (kg)	22 / 23
Package Size (mm)	530x500x110
QTY / 20'CY (PCS)	780

UE-K0202A:
Stroke: 73 mm
Min.Height: 126 mm

UE-K0210B:
Stroke: 135 mm
Min.Height: 358 mm

UE-K0205B:
Stroke: 130 mm
Max.Length: 665 mm

UE-K0210A:
Stroke: 58 mm
Min.Height: 118 mm

UE-K0204A:
Stroke: 18 mm
Min.Height: 40 mm

UE-K0202B:
Stroke: 120 mm
Max.Length: 575 mm

UE-K0204B:
Stroke: 125 mm
Min.Height: 270 mm

Air Hydraulic Pump

UE-A5200



Model	UE-A5200
Work Pression	70 Mpa
Oil Tank	1.6L
N.W. / G.W. (kg)	16.8 / 17.3
Package Size (mm)	340x310x250
QTY / CTN (PCS)	2
QTY / 20'CY (PCS)	2000

Model	UE-A3401
Work Pression	70 Mpa
Oil Tank	0.625L
N.W. / G.W. (kg)	14.5 / 15
Package Size (mm)	410x390x220
QTY / CTN (PCS)	2
QTY / 20'CY (PCS)	2000

For use with a variety of rams, pressing tools and hydraulic tools. Operates at 10,000 PSI. Air Pressure 0.6-1.0 Mpa

UE-A3401



Scissor Jack

NEW
PRODUCT



UE-T10104
1 Ton

NEW
PRODUCT



UE-T10154
1.5 Ton

Model	Capacity	Min. Height (mm)	Max. Height (mm)	Total Length (mm)	Stroke With Rated load (mm)	N.W. / G.W. (kg)	Package Size (mm)	QTY/ CTN (PCS)	QTY/20'CY (PCS)
UE-T10104	1 Ton	80	330	365	124	1.5/1.65	475x395x200	10	6000
UE-T10154	1.5 Ton	100	370	415	135	2.15/2.3	505x405x240	10	5000
UE-T10102-GS	1 Ton	88	380	426	200-370	2.5 / 2.8	500x455x255	10	4950
UE-T10152-GS	1.5 Ton	95	390	450	230-390	3.3 / 3.5	660x470x230	10	3600
UE-T10202-GS	2 Ton	120	395	450	260-390	3.5 / 4	660x470x260	10	4800
UE-T101010	1 Ton	138	355	380	/	6.78/7.88	428x320x205	2	2000

Wheel Chocks



UE-F3553

Model UE-F3553
Product Size 105x85x90 mm
N.W. / G.W. 0.7 kgs/pair / 0.8 kgs/pair
Package Size 370x230x120 mm
QTY/CTN 10 pairs
QTY/20'CY 20000 pairs

Steel

One Piece



UE-TS001

Model UE-TS001
Product Size 220x195x155mm
N.W. / G.W. 2.2 kgs / 2.45 kgs
Package Size 350x300x225mm
QTY/CTN 8 PCS
QTY/20'CY 9000 PCS

Rubber



UE-F3553-1

Model UE-F3553-1
Product Size 105x85x90 mm
N.W. / G.W. 0.7 kgs/pair / 0.8 kgs/pair
Package Size 370x230x120 mm
QTY/CTN 10 pairs
QTY/20'CY 20000 pairs

Steel

Rubber Mat

One Piece



UE-TS007

Model UE-TS007
Product Size 230x180x140 mm
N.W. / G.W. 3.5 kgs / 4 kgs
Package Size 500x360x180mm
QTY/CTN 6 PCS
QTY/20'CY 4500 PCS

Rubber



UE-F3554

Model UE-F3554
Product Size 152x125x52mm
N.W. / G.W. 0.91 kgs/pair / 0.94 kgs/pair
Package Size 445x285x170mm
QTY/CTN 16 pairs
QTY/20'CY 21000 pairs
MOQ 160 pairs

Steel

For SUV

One Piece



UE-TS002

Model UE-TS002
Product Size 280x240x180mm
N.W. / G.W. 5.7 kgs / 6 kgs
Package Size 500x360x180mm
QTY/PLT 4 PCS
QTY/20'CY 3200 PCS

Rubber

Industrial Toe Jack



Model	Toe Capacity	Head Capacity	Min. Toe Height (mm)	Max. Toe Height (mm)	Min. Head Height (mm)	Max. Head Height (mm)	Base Size (mm)	N.W. / G.W. (kg)	Package Size (mm)	QTY/20'CY (PCS)
UE-J7102 2 Ton	3 Ton	3 Ton	15.8	128.5	238	349	127x177.8	10/10.5	265x200x310	1900
UE-J7105 5 Ton	6 Ton	6 Ton	22.2	141.3	298.5	409.5	270x184	22.5/23	320x257x358	800
UE-J7110 10 Ton	14 Ton	14 Ton	28.6	173	333.4	460.4	285.8x241.3	33.5/34	365x298x395	450



Model	Toe Capacity	Head Capacity	Min. Toe Height (mm)	Max. Toe Height (mm)	Min. Head Height (mm)	Max. Head Height (mm)	N.W. / G.W. (kg)	Package Size (mm)	QTY/20'CY (PCS)
UE-J7205	2 Ton	5 Ton	25	230	368	573	22.5/25	365x200x430	700
UE-J7210	5 Ton	10 Ton	30	260	420	650	32.5/35	380x225x485	500
UE-J7225	10 Ton	25 Ton	58	273	505	720	109 / 116	530x350x610	150

Ratchet Steel Jack

UE-J7310-5T
5 Ton

UE-J7310-10T
10 Ton

UE-J7310-16T
16 Ton

UE-J7310-20T
20 Ton



UE-J7310-1.5T
1.5 Ton

UE-J7310-3T
3 Ton

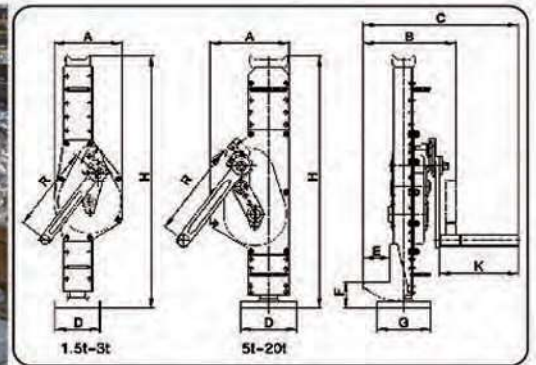

Model	UE-J7310-1.5T	UE-J7310-3T	UE-J7310-5T	UE-J7310-10T	UE-J7310-16T	UE-J7310-20T
Rated Capacity(Ton)	1.5	3	5	10	16	20
Stroke(mm)	300	350	350	410	320	320
Min. Height(mm) F	60	70	80	85	95	100
Max. Height(mm) H	600	730	730	800	800	860
Product Size(mm) A	163	197	189	250	275	275
B	190	200	239	293	320	335
C	273	296	335	498	514	529
D	100	130	140	140	150	150
E	55	60	71	86	78	78
G	110	140	170	170	180	180
K	113	127	127	248	250	250
R	225	250	275	300	300	380
N.W./G.W.(kg)	13.5 / 16	21.2 / 22	28.5 / 30	46.8 / 49	65 / 68	75 / 78
Package size(mm)	620x180x190	760x260x230	790x220x280	850x290x340	850x320x350	920x320x350
QTY/20'CY(PCS)	1100	743 PCS	534 PCS	310 PCS	273 PCS	230 PCS

Air Jack



UE-A3812
2 Ton

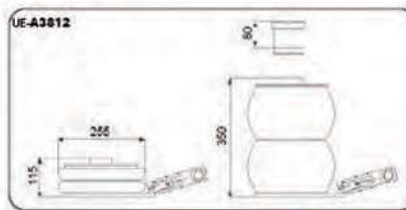

UE-A3813
2 Ton

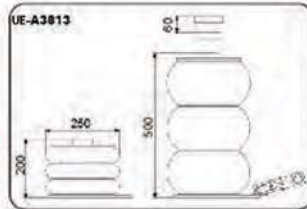

UE-A1812
2 Ton

UE-A1813
2 Ton

Model	UE-A3812	UE-A1812	UE-A3813	UE-A1813
Capacity	2 Ton	2 Ton	2 Ton	2 Ton
Min. Height(mm)	115	115	200	200
Max. Height(mm)	430	430	560	560
Lifting Time	3 sec	3 sec	4 sec	4 sec
Working Temp	-60°C ~ 50°C	-60°C ~ 50°C	-60°C ~ 50°C	-60°C ~ 50°C
N.W. / G.W. (kg)	15 / 16	18 / 19	16 / 17	19 / 20
Package Size (mm)	510x290x140	1300x280x140	490x280x230	1300x280x220
QTY/20'CY (PCS)	850	450	700	270

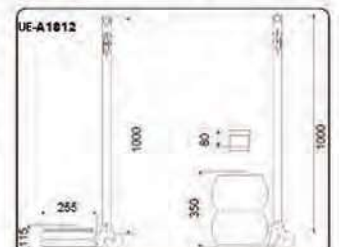

Off-Road Jack

- Multi-functional tool is great for lifting tractors or heavy trucks, pulling posts and poles, and even serves as an all-purpose hoist or winch.



UE-A8205
20"



UE-A8335
33"



UE-A8485
48"



UE-A8605
60"

Model	UE-A8205	UE-A8335	UE-A8485	UE-A8605
Capacity	3 Ton	3 Ton	3 Ton	3 Ton
Base Size (mm)	177.8x114.3	177.8x114.3	177.8x117.4	177.8x117.4
Product Height (mm)	508	838.2	1219.2	1524
Min.Height (mm)	125	125	125	125
Max.Height (mm)	318	660	1020	1330
N.W. / G.W. (kg)	9 / 10	11 / 12	14 / 15	14.5 / 15.5
Package Size (mm)	540x280x145	870x280x145	1250x280x145	1550x280x145
QTY/20'CY (PCS)	1320	950	650	550



UE-A8485(GS)
48"



UE-A8605(GS)
60"



Model		UE-A8485(GS)	UE-A8605(GS)
Max. SupportLoad (kg)	130 mm ≤ H < 300 mm	2000 kgs	2000 kgs
	300 mm ≤ H < 500 mm	1600 kgs	1600 kgs
	H ≥ 500 mm	500 kgs	500 kgs
Lifting Range (mm)		130-1060	130-1325
Base Size (mm) (WxLxT)		260x120x5	260x120x5
N. W. / G.W. (kg)		13 / 14	14.5 / 15.5
Package Size (mm)		1255x250x145	1555x250x145
QTY/20'CY (PCS)		580	480

UE-8485-7

Anti-skid Ramp



High Strength Nylon Material

Model	Product Size (mm)	N.W. / G.W. (kgs / CTN)	Package Size (mm)	QTY/CTN
UE-8485-7	1100x350x100	5.4 / 6.2	1100x350x100	2 PCS

UE-8485-8

Anti-skid Ramp

Foldable



Model	Product Size (mm)	N.W. / G.W. (kgs / CTN)	Package Size (mm)	QTY/CTN
UE-8485-8	1200x340x40	10 / 10.5	450x250x150	2 PCS

UE-8485-5

Lift Mate



We've designed the TR8485-5 to provide a lift point from most wheels for quick and easy lifting.

Model	Capacity	N.W. / G.W. (kgs / CTN)	Package Size (mm)	QTY/CTN (PCS)
UE-8485-5	5000 Lbs.	22.6 / 23.6	540x230x250	10

UE-8485-4

Off-Road Base



The TR8485-4 fits all our models and helps prevent the jack from sinking on soft surfaces.

Model	N.W. / G.W. (kgs / CTN)	Product Size (mm)	Package Size (mm)	QTY/CTN (PCS)
UE-8485-4	9.3 / 10.3	350x310x150	410x330x340	5

Jack Stand



- Ratchet style allows for fine adjustment and fast removal.
- Solid steel handle, Self-Locking ratchet
- Large saddle, unitized frame construction
- Ductile iron rack

Complies with
ASME
Safety Standards

Model	Capacity	Min. Height (mm)	Max. Height (mm)	N.W. / G.W. (kg)	Package Size (mm)	QTY/20'CY
UE-T42002	2 Ton	275	420	4.75 / 5.1	195x180x350	2088 pairs
UE-T42002X	2 Ton	250	380	4.5 / 4.9	200x160x315	2740 pairs
UE-T43002	3 Ton	285	425	6.3 / 6.8	210x190x360	1944 pairs
UE-T43002X	3 Ton	270	410	5.9 / 6.2	195x180x330	2352 pairs
UE-T46002	6 Ton	390	610	12.4 / 13.2	290x255x460	880 pairs
UE-T412002	12 Ton	465	715	26.3 / 27.1	320x290x570	620 pairs

Foldable Jack Stand



UE-T42004
2 Ton



UE-T43004
3 Ton



UE-T46004
6 Ton

Model	UE-T42004	UE-T43004	UE-T46004
Capacity	2 Ton	3 Ton	6 Ton
Min. Height (mm)	278	286	375
Max. Height (mm)	366	401	570
N.W. / G.W. (kg)	3.38 / 3.58	3.88 / 4.11	8.27 / 8.85
Package Size (mm)	530x280x315	630x300x320	540x290x480
QTY / CTN	10 pairs	10 pairs	4 pairs
QTY / 20'CY	4730 pairs	4080 pairs	1280 pairs

Foldable Screw Jack Stand

HEAVY DUTY

UE-F3201
12 Ton
UE-F3202
12 Ton



Adjustable
Screw Height



Model	UE-F3202	UE-F3201
Capacity	12 Ton	12 Ton
Min. Height (mm)	710	456
Max. Height (mm)	1065	710
N.W. / G.W. (kg)	25 / 26.5	18.5 / 19.5
Package Size (mm)	210x410x880	210x410x610
QTY / 20'CY (PCS)	480	480

Vehicle Support Stand

NEW
PRODUCT



UE-YL2000
2000 KGS

Model	Capacity	Min. Height (mm)	Max. Height (mm)	N.W. / G.W. (kg)	QTY/CTN (Pairs)	Package Size (mm)	MOQ (Pairs)
UE-YL1200	1200 kgs	290	405	4.5 / 4.8	3	630x265x345	200
UE-YL1500	1500 kgs	315	415	5 / 5.3	3	630x265x345	200
UE-YL1800	1800 kgs	310	440	5.8 / 6.3	3	630x265x345	200
UE-YL2000	2000 kgs	310	435	5.9 / 6.4	3	630x265x345	200

Welding Jack Stand

UE-F31502-1
15 Ton



Model	Capacity	Min. Height (mm)	Max. Height (mm)	N.W. / G.W. (Piece) (kg)	Package Size (mm)	QTY/CTN (PCS)	QTY/20'CY (PCS)
UE-F30151-1	1.5 Ton	300	425	2 / 2.5	830x520x300	6	1200
UE-F30301-1	3 Ton	345	525	4.2 / 4.5	950x720x380	6	600
UE-F30502-1	5 Ton	390	660	9 / 12	570x570x580	1	300
UE-F31002-1	10 Ton	615	975	22.5 / 25.5	850x850x680	1	200
UE-F31502-1	15 Ton	615	975	28.4 / 29	870x870x680	1	200

Heavy-Duty Vehicle Support Stand



Underhoist Stand

UE-F42009
2 Ton



UE-TZ100002
10 Ton
(Tall)



Reinforced high stand with adjustment control pin

Model	UE-TZ100001	UE-TZ100002
Carrying Capacity	10 Ton	10 Ton
Min. Height (mm)	450	650
Max. Height (mm)	750	1100
N.W. / G.W. (kg)	19.5 / 21.5	24.5 / 26.5
Package Size (mm)	395x390x490	395x390x690
QTY / 20'CY (PCS)	280	210

Model	Capacity	Min. Height (mm)	Max. Height (mm)	N.W. / G.W. (kg)	Package Size (mm)	QTY/20'CY (PCS)
UE-F42008	2 Ton	1730	1950	16 / 17.5	1600x190x120	780
UE-F42009	2 Ton	1240	2145	17.5 / 18.5	1180x198x55	840
UE-F40753	0.75 Ton	1360	2030	14.3 / 17.8	1410x370x65	580
UE-F40753A	0.75 Ton	1360	2030	15.3 / 18.8	1410x370x65	580

Heavy-Duty Vehicle Support Stand

UE-T412009A
12 Ton



Model:	UE-T410009G	UE-T412009A
Capacity:	10 TON	12 TON
Min. Height (mm)	720	805
Max. Height (mm)	1190	1213
N.W. / G.W. (kgs)	23.5 / 26.38	29.3 / 30.8
Package Size(mm)	450x450x800	480x480x800
QTY/20'CY (PCS)	155	128

Engine Stand



UE-T23401
750 LBS



Model:	UE-T23401	UE-T24541
Capacity:	750 LBS	1000 LBS
Product Size	890x780x850 mm	925x780x850 mm
N.W.	18.5 kgs	21 kgs
G.W.:	19.6 kgs	22.3 kgs
Package Size:	880x200x195 mm	870x200x195 mm
QTY/20'CY:	740 PCS	740 PCS

Engine Leveler



UE-F20501
500 KGS



Model	UE-F20501	UE-F2750	UE-F2750A	UE-F22001
Capacity	500 kgs	680 kgs	680 kgs	2000 kgs
N.W. / G.W.	4.5 kgs / 4.8 kgs	5.2 kgs / 5.5 kgs	5.2 kgs / 5.5 kgs	5.4 kgs / 6 kgs
Package Size	700x370x260mm	480x280x220mm	480x280x220mm	600x290x270mm
	4 PCS	4 PCS	4 PCS	4 PCS
QTY/20'CY	1950 PCS	2750 PCS	2750 PCS	2680 PCS

Long Ram Jack

UE-TH30306 3 TON
UE-TH30506 5 TON
UE-TH30506X 5 TON



Welded

Model	Capacity	Min. Height (mm)	Max. Height (mm)	N.W. / G.W. (kg)	Package Size (mm)	QTY/CTN (PCS)	QTY/20'CY (PCS)
UE-TH30306	3 Ton	590	1085	11.38 / 11.88	610x160x130	2	1590
UE-TH30506	5 Ton	590	1085	11.68 / 12.18	610x160x130	2	1590
UE-TH30506X	5 Ton	560	1010	10.9 / 11.4	581x160x130	2	1690
UE-T30308	3 Ton	630	1115	11.4 / 11.7	705x280x150	2	1680
UE-T30508	5 Ton	635	1120	15 / 15.6	720x330x170	2	1326
UE-T30808	8 Ton	635	1120	15 / 15.6	720x330x175	2	1326

Engine Crane



Foldable

UE-T31002X
1 TON



Engine Support



Enging Support Bar
Two Directions Enging Suppor

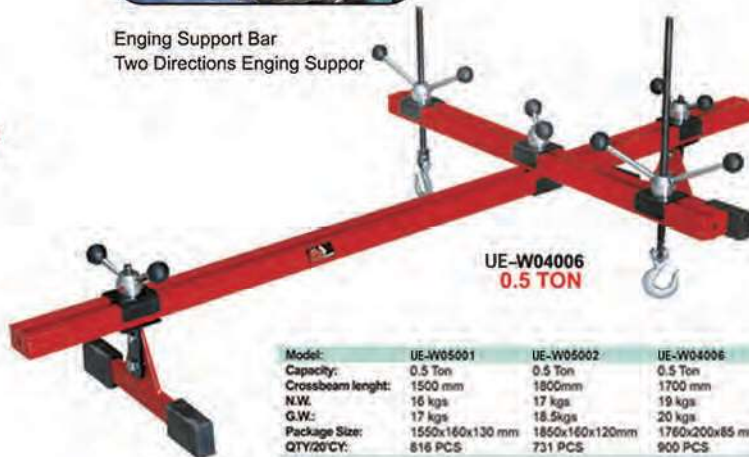

UE-W04006
0.5 TON

Model:	UE-W05001	UE-W05002	UE-W04006
Capacity:	0.5 Ton	0.5 Ton	0.5 Ton
Crossbeam length:	1500 mm	1800mm	1700 mm
N.W:	16 kgs	17 kgs	19 kgs
G.W:	17 kgs	18.5kgs	20 kgs
Package Size:	1550x160x130 mm	1850x160x120mm	1760x200x85 mm
QTY/20'CY:	816 PCS	731 PCS	900 PCS

Model:	UE-T31002X	UE-T31002X-GS	UE-T32002X	UE-T32002-GS
Capacity:	1 TON	1 TON	2 TON	2 TON
Lifting Range:	25~2040 mm	25~2040 mm	25~2240 mm	25~2435 mm
Length:	1510 mm	1510 mm	1615 mm	1740 mm
Width:	1015 mm	1015 mm	1010 mm	1040 mm
Height:	1545 mm	1545 mm	1480 mm	1580 mm
Package Size:	1# 520x460x130 mm 2# 1440x380x180 mm	1445x460x190 mm	1# 780x550x100 mm 2# 1480x320x180 mm	1# 890x600x100 mm 2# 1550x330x180 mm
N.W. / G.W.	1# 55 kgs / 58 kgs 2# 10 kgs / 11.8 kgs	65 / 69.8 kgs	1# 20.9 kgs / 22.36 kgs 2# 60 kgs / 63.2 kgs	1# 27.5 kgs / 29 kgs 2# 73.78 kgs / 75.92 kgs
QTY/20'CY	204 PCS	216 PCS	204 PCS	140 PCS



Hydraulic Shop Press

UE-TY06001
6 TON



UE-TY12003
12 TON



Paper Carton

Model:	UE-TY06001
Capacity:	6 TON
Stroke:	127 mm
Work Range:	0-230 mm
N.W.	22.5 kgs
G.W.	24 kgs
Package Size:	730x280x135 mm
QTY/20'CY	700 PCS

Model:	UE-TY12003
Capacity:	12 TON
Stroke:	175 mm
Work Range:	0~610 mm
N.W.	41 kgs
G.W.	43 kgs
Package Size:	1270x230x185 mm
QTY/20'CY	390 PCS

Professional Hydraulic Shop Press



Dustproof cover



Screw extension



Punches sets are Standard accessories



V-blocks & 180° guiding design



Special design for more height position of working table



Wooden Box



UE-SP50HAM
50 TON

Model	Capacity	Air Pressure	N.W. / G.W.	Package Size	QTY/20'CY
UE-SP30HM	30 Ton	/	200 / 207 kgs	1800x850x350mm	25 PCS
UE-SP30HAM	30 Ton	0.9-1.2Mpa	200 / 207 kgs	1800x850x350mm	25 PCS
UE-SP50HAM	50 Ton	0.9-1.2Mpa	280 / 288 kgs	1900x1000x450mm	20 PCS

Model	Capacity	A	B	C	D	E	G1	G2	R	R1	R2	M
UE-SP30HM	30 Ton	770	600	1800	148	505	25	850	220	145	75	200
UE-SP30HAM	30 Ton	770	600	1800	148	505	25	850	220	145	75	200
UE-SP50HAM	50 Ton	930	750	1900	200	535	80	780	220	145	75	280

Transmission Jack

UE-TEL05006
0.5 TON
CE



Single Pump



Complies with
ASME
Safety Standards

Telescoping
Cylinder Rams



UE-TEL05005
0.5 TON
CE



Double Pump

Model	Capacity	Min. Height	Max. Height	N.W.	G.W.	Package Size	QTY/20'CY
UE-TEL05001	0.5 Ton	1260 mm	1735 mm	33 kgs	35.5 kgs	685x430x190 mm	473 PCS
UE-TEL03004S	0.3 Ton	1140 mm	1945 mm	24 kgs	28.5 kgs	1110x280x155 mm	600 PCS
UE-TEL05004S	0.5 Ton	1140 mm	1945 mm	24 kgs	28.5 kgs	1110x280x155 mm	600 PCS
UE-TEL05006	0.5 Ton	875 mm	1855 mm	76 kgs	85 kgs	580x330x865 mm	134 PCS
UE-TEL05005	0.5 Ton	890 mm	1795 mm	57 kgs	65 kgs	530x320x750 mm	222 PCS

Temperature-control Timing Vulcanizing Machine

UE-AD001

Characteristics and performance:

The machine is of automatic constant temperature. It is featured by power signal indication, short circuit protection, and optional fixed-time work or normally ON, etc.

It is mainly applicable to the repair of various tube tires, small-size cover tyres and vacuum tires.



UE-AD001Q

PNEUMATIC



Technical Specification

Model	UE-AD001	UE-AD001Q
Input voltage	220 V or 110V	220 V or 110V
Input power	500 W	500 W
Temperature range	145-165 °C	145-165 °C
Repair area	60×60 mm ²	60×60 mm ²
Single G.W/N.W	8.3/7.9 kgs	8.95/7.9 kgs
Single package size	325×190×390 mm	330×195×510 mm
G.W/N.W.	34.35/33 kgs	37.5/35.8 kgs
QTY/CTN	4 PCS	4 PCS
Packgae size	675×405×410 mm	685×415×535 mm
QTY/20'CY	200 PCS	160 PCS

Tire Vulcanizing Machine

Technical Specification

Model	UE-AD009	UE-AD009Q
Working voltage	220 V	220 V
Maximum power	≈2000 W	≈2000 W
Repair temperature	lower mold 160°C, upper mold 150±10°C, and side mold 150±10°C (the temperature of lower mold is adjustable)	
N.W. / G.W.	82 / 107 kgs	85.6/120 kgs
Packgae size	775×600×1300 mm	775×600×1810 mm
QTY/20'CY	170 PCS	170 PCS

Characteristics and performance

- Use together with up, down and side mold, to better repair all sides of tires.
- Top arm and side arm can turn 90°

UE-AD009



UE-AD009Q



Press Mold Tire

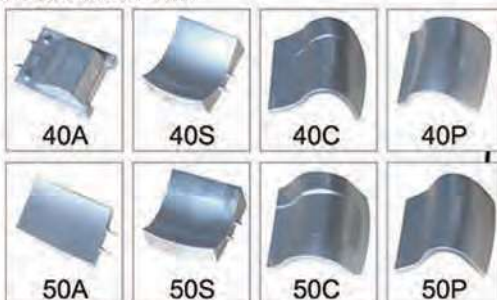

Tire Expander

Air lifting work platform for easy loading and working for the tire. 360 degree rotate work platform and LED light easy for using. Fit for less than 1200R20 tire.

Technical Specification

Biggest enlargem	350 mm
Input voltage	85-265V
Lifting height	660 mm
Working pressure	0.6-0.8Mpa
N.W. / G.W.	114.9 / 155.7 kgs
Package size	1300x850x880 mm
QTY/20'CY	16 PCS



Combi Bead Breaker

UE-ND6100
10 Ton



UE-ND6220
10 Ton

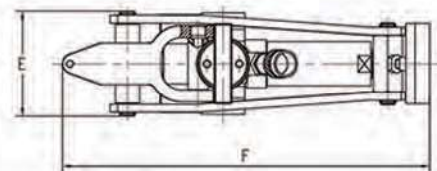
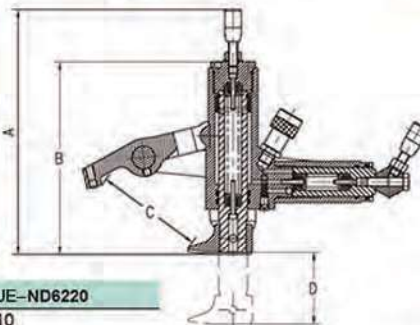

Model:	UE-ND6100	UE-ND6220
Capacity(Ton):	10	10
Pressure(Mpa):	70	70
QTY/Pack:	1	1
N.W./G.W.(kgs):	12.5/13.5	15.5/16.5
Package Size(mm):	390x390x160	390X390X160
QTY/20'CY:	1300	1300
MOQ:	50	50

Model	Capacity TON	Pressure Mpa	A	B	C	D	E	F
UE-ND6220	10	70	325	256	150	95	131	456
UE-ND6100	10	70	327	258	131.5	95	138	449

Tire Bead Blaster

Model:	UE-AD018	UE-AD018K	UE-AD036	UE-AD036K	UE-AD07A
Work Pressure:	0.6-0.8 Mpa	0.6-0.8 Mpa	0.6-0.8 Mpa	0.6-0.8 Mpa	0.6-0.8 Mpa
Max. Work Pressure:	1.0 Mpa	1.0 Mpa	1.0 Mpa	1.0 Mpa	1.0 Mpa
Capacity:	5 Gallon	5 Gallon	10 Gallon	10 Gallon	1.8 Gallon
N.W.:	11kgs	10.7 kgs	15 kgs	15 kgs	3.5 kgs / 1 pcs
G.W.:	12 kgs	11.7kgs	17 kgs	17 kgs	4.2 kgs / 1 pcs
Package Size:	435x410x300 mm	490x420x300 mm	575x430x340 mm	575x485x340 mm	600x190x240 mm / 1 PC
QTY/20'CY:	450 PCS	415 PCS	280 PCS	280 PCS	972 PCS
					16.8 Kgs / 4 pcs
					18 Kgs / 4 pcs
					615x405x525 mm / 4 PCS
					720 PCS

UE-AD036
10 Gallon



Air Tank



UE-TG80501
5 Gallon

Model:	UE-TG80501	UE-TG80701	UE-TG81101
Capacity:	5 Gallon	7 Gallon	11 Gallon
N.W.:	6.8 kgs	8.3 kgs	11 kgs
G.W.:	7.5 kgs	9.4 kgs	12 kgs
Package Size:	495x285x300 mm	450x335x375 mm	620x330x370 mm
QTY/20'CY:	673 PCS	500 PCS	378 PCS

Hydraulic Ram Straightening Machine with Lathe

This unique machine is used to correct and straighten all kinds of defected steel and alloy rims ranging from 10" to 26".

UE-E595M



Technical Specification

Motor Specifications	Mechanic 0.55 kw, 1400 rpm, 0.75 hp, 220V - 380 V
	Hydraulic 0.75 kw 1400 rpm, 1 hp, 220V - 380 V
	Noise level 35 db
Hydraulic Piston Power	Total pressure = $\pi r^2 \times 160$ (Working pressure bar)
	Total pressure = $3.14 \times (3.15 \times 3.15) = 31,156$ kgs Total pressure = $31,156 \times 160 = 4,984,96$ kgs
Dimensions	Height 1250 mm ,Width 1110 mm ,Length 610 mm
Package Size	1370x880x1495 mm
N.W./G.W.	370/400 kgs
QTY/20'CY	11 PCS



Brake Lathe

UE-E9350

Quickly, accurately and efficiently to cutting rotor fast and slow setting allow cutting rotor;
 Quickly, accurately and efficiently to cutting drum, Finitely adjustably setting allow cutting drum ;
 Three kinds of speed to choice for spindle speed ;
 A convenient design allows to quickly change from rotor to drum;
 Position of stop make the lathe stop automatic after the cutting ;
 Fully equipped adapter package

Technical Specification

Spindle Travel	6-7/8" / 175 mm
Spindle Speed	70, 80, 118 RPM
Spindle Feed Speed	Min 0.002 Inch Per Revolution / 0.05 Mm/Rev Max 0.02 Inch Per Revolution / 0.5 Mn/Rev
Cross Feed Speed	Min 0.002 Inch Per Revolution / 0.05 Mn/Rev Max 0.01 Inch Per Revolution / 0.025 Mn/Rev
Handwheel Graduations	0.002" / 0.05 mm
Motor Diameter	7" / 180 mm - 15" / 381 mm
Motor Thickness	1-7/8" / 48 mm
Drum Diameter	6" / 152 mm - 28" / 711 mm
Drum Depth	6-7/8" / 175 mm
Motor	1 PH 220V 50/60Hz 3 PH 380V 50/60Hz
G.W./N.W.	290/240 kgs
Package Size	970X950X1140 mm
QTY/20'CY	20 PCS



Lifting Table Cart



Handle Heavy Loads!
 Lift and lower heavy cargo for smooth, easy loading and unloading! Ideal for transporting machinery and big tool chests, unloading trucks and more. Foot-pedal operates hydraulic tabletop. Handle-mounted pressure release. Truck ship.

150 KGS

UE-TP01501



Model	Capacity(kgs)	Lifting Range(mm)	Package Size(mm)	N.W.(kgs)	G.W(kgs)	QTY/20'CY(PCS)
UE-TP01501	150	220-730	835x500x250	43	45	234
UE-TP03001	300	270-760	945x550x295	58	61	168
UE-TP04001	400	360-1290	1050x560x400	104	121.5	100
UE-TP05001	500	280-860	965x565x305	76	79	154

Car Dolly

sold in pairs



UE-F0322
450 Kgs

Model:	UE-F0322
Capacity:	450 kgs
N.W.:	18 kgs (Pair)
G.W.:	18.5 kgs (Pair)
Overall Size:	602x385x140 mm
Package Size:	635x420x115 mm
QTY/20'CY:	810 Pairs

sold in pairs



UE-F0323
450 Kgs

Model:	UE-F0323
Capacity:	450 kgs
N.W.:	15.6 kgs (Pair)
G.W.:	16.5 kgs (Pair)
Overall Size:	410x300x100 mm
Package Size:	420x320x128 mm
QTY/20'CY:	1500 Pairs

Hydraulic Self-loading Dolly



UE-A9012L 12"

CE



Aluminum

Heavy Duty Wheel

Model:	UE-A9009	UE-A9012	UE-A9012L
Capacity:	680 kgs	680 kgs	680 kgs
N.W.:	17 kgs	18 kgs	18.5 kgs
G.W.:	18 kgs	20 kgs	20.5 kgs
Package Size:	620x620x220 mm	680x620x220 mm	680x620x220 mm
QTY/20'CY:	320 PCS	290 PCS	290 PCS

Mechanic Tyre Dolly

NEW
PRODUCT



Model:	UE-TX00603
capacity:	60 Kgs
Working Range:	238-443 mm
Net Weight:	5.7 Kgs
Gross Weight:	6.5 Kgs
Product Size:	619x484x183 mm
Package Size:	620x150x120 mm
Qty/20' cy:	2000 PCS

UE-TX00603

Hydraulic Pallet Jack

Characteristic:

- High quality integrated cast cylinder
- Oil cylinder is equipped with permanent flow valve to ensure steady descend for the goods because of over loading.
- High-balanced intensifying frame
- Economical, superior cost performance
- High strength "C" type fork
- High strength welding hydraulic, preure oil cylinder, equipped with safety valve

CE

UE-E8220A

2000 / 2500/3000 Kgs



CE

UE-E8220C

4000 / 5000 kgs



CE

UE-E8220B

2000 / 2500 / 3000 kgs

Model	UE-E8220A		UE-E8220B		UE-E8220C	
Capacity	2000 / 2500 / 3000 kgs		2000 / 2500 / 3000 kgs		4000 / 5000 kgs	
Fork Width	550 mm	685 mm	550 mm	685 mm	550 mm	685 mm
Fork Length	1100 mm	1220 mm	1100/1150 mm	1220 mm	1100 mm	1220 mm
Max.Fork Height	195 / 185 mm		195 / 185 mm		185 / 175 mm	
Min.Fork Height	85 / 75 mm		85 / 75 mm		85 / 75 mm	
Max.lifting Height	≥110 mm		≥110 mm		≥110 mm	
Material of the Front Wheel / Loaded Wheel	Nylon / Rubber / Polyurethane		Nylon / Rubber / Polyurethane		Nylon / Rubber / Polyurethane	
N.W. / PC	75 kgs	80 kgs	75 kgs	85 kgs	155 kgs	175 kgs
G.W. / PC	85 kgs	90 kgs	85 kgs	90 kgs	160 kgs	180 kgs
Package Size	2200x560x760 mm	2300x700x700 mm	2200x560x760 mm	2300x700x700 mm	2000x600x700 mm	2200x700x700 mm
QTY / Package	6 PCS	6 PCS	6 PCS	6 PCS	4 PCS	4 PCS
QTY / 20'CY	180 PCS	144 PCS	180 PCS	144 PCS	120 PCS	96 PCS

Hand Pallet Stacker



UE-E8315
1500 kgs



Adjustable Fork

UE-E8315G
1500 kgs



Model	Capacity (kgs)	Lifting Height (mm)	Lowered Fork Height (mm)	Fork Length (mm)	Fork Width (mm)	Front Wheel (mm)	Loaded Wheel (mm)	Base Leg Width (mm)	Base Leg Inner Width (mm)	Overall Size (mm)	N.W/G.W (kgs)	Package Size (mm)	QTY/20' CY (PCS)
UE-E8315	1500	1600	85	1150	330-740	Φ80x58	Φ180x50	690	490	1600x760x2030	240/242	1600x760x2030	29
UE-E8315G	1500	1600	85	1150	550	Φ80x58	Φ180x50	490	290	1600x760x2030	240/242	1600x760x2030	29
UE-E8320	2000	1600	85	1150	330-740	Φ80x58	Φ180x50	690	490	1600x760x2030	270/272	1600x760x2030	29
UE-E8310E	1000	3000	85	1150	550	Φ80x58	Φ180x50	490	290	1600x760x2080	330/332	1600x760x2080	29

Tire Dolly



UE-X4209
300 Kgs

Model: UE-X4209
Capacity: 300 Kgs
N.W.: 18 kgs
G.W.: 18.5 kgs
Package Size: 1540x620x440 mm
QTY/20' CY: 200 PCS



UE-X01505
250 Kgs



Model: UE-X01505
Capacity: 250 kgs
Suitable tyre size: 165-570 mm
N.W.: 13.5 kgs
G.W.: 15 kgs
Package Size: 730x185x140 mm
QTY/20' CY: 980 PCS

UE-X01506
100 Kgs

Model: UE-X01506
Capacity: 100 kgs
Package Size: 730x660x90 mm
N.W.: 5.5 kgs
G.W.: 6 kgs
QTY/20' CY: 620 PCS

Portable Tire Changer

Model: UE-K60001
 N.W.: 27 kgs
 G.W.: 39 kgs
 Package Size: 740x555x360 mm
 QTY/20' CY: 170 PCS

UE-K60001

→ Size Adjustable ←



Tire Changer

Model: UE-K26101
 N.W.: 13.5 kgs
 G.W.: 15.5 kgs
 Package Size: 890x305x310 mm
 QTY/20' CY: 300 PCS

UE-K26101



Dual Wheel Dolly



Model: UE-TX12007
 Capacity: 1.5 Ton
 Lifting Range: 0-770 mm
 Product Size: 1390x1065x1375 mm
 N.W.: 112 kgs
 G.W.: 145.5 kgs
 Package Size: 1400x805x475 mm
 QTY/20' CY: 44 PCS

UE-TX12007
1.5 Ton

UE-WL80
70 KGS

Model: UE-WL80
 Capacity: 70Kgs
 Max.Height: 1290mm
 Updown Speed: 0.02m/s
 Batteries: 12v-12Ah
 Base: 330x380mm
 N.W: 72kgs
 G.W: 91kgs
 Package Size: 1050x750x2050mm
 Qty/20'CY: 16PCS



BATTERY

Hydraulic Drum Transporter

Model:	UE-GA2502
Capacity:	250 kgs
Lifting Height:	280 mm
Max.Diameter:	600 mm
Max.Length:	915 mm
Overall Length:	800 mm
Overall Width:	760 mm
Overall dimension:	820x780x1250 mm
N.W.:	40 kgs
G.W.:	45 kgs
QTY/Package:	2 PCS/CTN
Package Size:	900x900x350 mm
QTY/20' CY:	72 PCS



UE-GA2502
250 Kgs



Drum Transporter

Model:	UE-TC0107
Capacity:	300 Kgs
N.W.:	15 kgs
G.W.:	17 kgs
Package Size:	840x590x220 mm
QTY/20'CY:	250 PCS

UE-TC0107
300 Kgs



Model:	UE-X10001
Capacity:	1 Ton
N.W.:	68 kgs
G.W.:	75 kgs
Product Size:	1040x1090x890 mm
Package Size:	1160x900x160 mm
QTY/20' CY:	150 PCS



UE-TRX10001
1 Ton

Forklift Jack

Model:	UE-TC50001
Lifting Capacity:	Scissors end 4 Ton Scissors post 5 Ton
Min. Height:	Scissors end 70 mm Scissors post 420 mm
Max.Height:	Scissors end 440mm Scissors post 740 mm
N.W.	45 kgs
G.W.:	46.5 kgs
Package Size:	745x263x340 mm
QTY/20'CY:	361 PCS

Scissor Post



UE-TC50001
4 Ton / 5 Ton



Spring Compressor

CE

UE-K1500-2
1 Ton



Model:	UE-K1500-2
Capacity:	1 Ton
Compression Length:	210-570 mm
Ram Travel:	325 mm
Spring Size:	101.6-254 mm
Compressed Spring Diameter:	400 mm
N.W.:	31 kgs
G.W.:	36 kgs
Package Size:	1230x290x190 mm
QTY/20'CY:	300 PCS

UE-K1500-3
1 Ton



Model:	UE-K1500-3
Capacity:	1 Ton
Compressed Spring Diameter:	200 mm
Compression Length:	200-500 mm
N.W.:	28.5 kgs
G.W.:	32.5 kgs
Package Size:	830x350x190 mm
QTY/20'CY:	300 PCS

CE

UE-K1500-5
1 Ton



PNEUMATIC

Model:	UE-K1500-5
Capacity:	1 Ton
Max Working Length:	480 mm
Spring Size:	210-570 mm
N.W.:	34 kgs
G.W.:	38 kgs
Package Size:	1200x290x220 mm
QTY/20'CY:	450 PCS



UE-K1500-6
1 Ton



OPTION

Model:	UE-K1500-6	UE-K1500-6C (with cover)	UE-K1500-6Q	UE-K1500-6QC (with cover)
Capacity:	1 Ton	1 Ton	1 Ton	1 Ton
Compressed Spring Diameter:	400 mm	400 mm	400 mm	400 mm
Compression Length:	210-570 mm	210-570 mm	210-570 mm	210-570 mm
N.W.:	30 kgs	31.5 kgs	30 kgs	31.5 kgs
G.W.:	34 kgs	35.5 kgs	34 kgs	35.5 kgs
Package Size:	1190x290x220 mm	1190x290x220 mm	1190x290x220 mm	1190x290x220 mm
QTY/20'CY:	300PCS	300PCS	300PCS	300PCS



K1500-6Q
1 Ton

Spring Compressor

UE-K3211
1 Ton



PNEUMATIC

CE

Model:	UE-K3211
Capacity:	1 Ton
Ram Stroke:	150 mm
Compressed Spring Diameter:	100-200 mm
Working Length:	290 mm
N.W.:	24.5 kgs
G.W.:	25.5 kgs
Package Size:	700x190x250 mm
QTY/20'CY:	800 PCS

Pick-up Truck Crane



UE-F2108
0.5 Ton

UE-F30603
0.5 Ton

UE-F30605
1 Ton

UE-F30604
1 Ton

Model	Capacity	Min. Height (mm)	Max. Height (mm)	N.W. / G.W. (kgs)	Package Size (mm)	QTY/20'CY (PCS)	MOQ (PCS)
UE-F2108	0.5 Ton	870	1800	43 / 45	1070x270x210	350	-
UE-F30603	0.5 Ton	0	2015	1# 7.5 / 8.7 2# 29 / 30	1# 290x290x330 2# 1090x270x200	290	20
UE-F30605	1 Ton	180	1710	1# 13 / 14 2# 33 / 35	1# 340x330x320 2# 1130x280x180	200	50
UE-F30604	1 Ton	0	2300	1# 18 / 20 2# 35 / 37	1# 275x275x310 2# 1260x300x240	200	20

TELESCOPING GANTRY CRANE



UE-AL1130-1
1000 Kgs

Mini Tilting Lift



UE-TAL15001
1500 Kgs

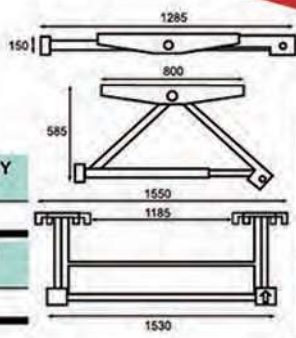

Model	Capacity	Min. Height (mm)	Max. Height (mm)	N.W./G.W. (kgs)	Package Size (mm)	QTY/20'CY (PCS)
UE-AL1130-1	1000 kgs	2384	3625	236/270	2860x640x360	36

Model	Capacity	Net Weight (kgs)	Gross Weight (kgs)	Package Size (mm)	QTY/20'CY (PCS)
UE-TAL15001	1500 kgs	58	75	1700x860x260	33

Auto Twirler

The Auto Twirler is a universal restoration rotisserie that lets user twirl a car body or body/frame 360 and lock in any position to allow easy access to hard-to-reach areas. Makes welding, rust vrepair, scraping, blasting, cleaning, painting and other restoration tasks much easier. Holds up to 1 ton. Can be made short enough to hold a truck cab, or extended up to 20 feet to hold a full-sized 1960s American muscle car. Rolls on 6 heavy-duty swivel casters. Plus model includes two 3-ton hydraulic jacks. 2 balancer attachments. Requires 8-ft. ceiling and 1702 mm base width for clearance.



UE-AL15003
1 Ton

Model	Capacity	Min. Height (mm)	Max. Height (mm)	Adjusting Width (mm)	Adjusting Length (mm)	N.W. / G.W. (kgs)	Package Size (mm)	QTY/20'CY (PCS)
UE-AL15003	1 Ton	520	1280	420 - 1240	3600 - 5000	225 / 260	1880x825x400	30

Car Mini Lift



UE-A6000B
1.5 Ton



UE-A6000
1.5 Ton

PNEUMATIC

Air Bumper Jack



UE-A2500
1.25 Ton



Model	Capacity	Max. Height (mm)	N.W. / G.W. (kgs)	Package Size (mm)	QTY/20'CY (PCS)	MOQ (PCS)
UE-A6000	1.5 Ton	1100	110 / 115	1110x730x300	100	5
UE-A6000B	1.5 Ton	1100	110 / 115	1110x730x300	100	5

Model	Capacity	Min.H (mm)	Max.H (mm)	Lifting.H (mm)	N.W. / G.W. (kgs)	Package Size (mm)	QTY/20'CY (PCS)
UE-A2500	1.25 Ton	280	1080	800	88 / 89	950x940x1200	20

Fender Reforming Tool

UE-F06011



Model:	UE-F06011
N.W.:	7 kgs
G.W.:	8 kgs
Package Size:	370x350x150 mm
QTY/20'CY:	1500 PCS

Introduction:

1. Use for fender collision repair or fender or to increase fender clearance;
2. Fit most cars and light trucks with 4 or 5 lugs;
3. Simple and easy to use;
4. Roller works on fender from inside wheel well;
5. Attached hitch pin allows for wide or narrow angle;
6. Adjustable arm has second telescoping arm with roller that allows for 180 degrees wheel swivel

Frame Straightener

Model:	UE-TW10001
Capacity:	10 Ton
N.W.:	165 kgs
G.W.:	190 kgs
Package Size:	3030x400x330 mm
QTY/20'CY:	50 PCS

CE

UE-TW10001
10 Ton

**100°
Angle**



UE-TW10002
10 Ton

Model:	UE-TW10002
Capacity:	10 Ton
N.W.:	170 kgs
G.W.:	200 kgs
Package Size:	3040x400x330 mm
QTY/20'CY:	50 PCS

Hydraulic Pipe Bender

UE-M03003-2
16 Ton



Model: UE-M03003-2
Package Size: 770x360x235 mm
N.W.: 67 kgs
G.W.: 72 kgs
QTY/20'CY: 270 PCS

Mould Size						
Metric system (mm)	British System (in)	Outer Diameter (mm)	Thickness (mm)	Pipe bending Pressure (kg)	Working Stroke (mm)	Angle (°)
15	1/2"	21.25	2.75	70/2490T	61	285
20	3/4"	26.75	2.75	70/2490T	61	285
25	1"	33.50	3.25	70/2490T	61	285
32	1-1/4"	42.25	3.25	70/2490T	61	285
40	1-1/2"	48	3.50	70/2490T	61	285
50	2"	60	3.50	70/2490T	61	285
65	2-1/2"	75.50	3.75	70/2490T	61	285
80	3"	88.50	4	70/2490T	61	285



Model: UE-A1202
Capacity: 12 Ton
N.W.: 32 kgs
G.W.: 34 kgs
Package Size: 650x560x200 mm
QTY/20'CY: 420 PCS

UE-A1202
12 Ton

Compact tubing bender



UE-A6002

Model UE-A6002
Die Size: 25.4mm,31.75mm,38.1mm,44.45mm, 50.8mm,63.5mm,67mm
N.W.: 16 kgs
G.W.: 18 kgs
Package Size: 700x280x130 mm
QTY/20'CY: 850 PCS
MOQ: 30 PCS



UE-A6001

Model UE-A6001
Die Size: 25.4mm,31.75mm,38.1mm,44.45mm, 50.8mm,63.5mm,67mm
N.W.: 24 kgs
G.W.: 26 kgs
Package Size: 920x280x270 mm
QTY/20'CY: 650 PCS
MOQ: 30 PCS

Auto Multi-functional Paint Stand

Nonpolar rotation;PU universal brake wheel move freely;Handle,pedal adjustment lock anywhere;Brace bar height is adjustable.Fix engine hood,panel etc;Process both polishing and painting on the stand, can move to spray booth freely.

UE-X010001 Size:6+2 UE-X010002 Size:8+2
 Package Size: 1230X300X170mm Package Size: 1970X320X180mm
 N.W.:28 kgs N.W.:33 kgs
 G.W.:30 kgs G.W.:34.5 kgs



UE-X010001

UE-X010002

X Shape Engine Hood And Windshield Stand

This stand is used for laying windshield or engine hood;4 universal wheels make it easy to move;Width and height can be adjustable freely;Top contact surface is rubber,to avoid scratches. (Mainly used for windshield moving and making adhesive)

Package Size: 1060x320x130 mm
 N.W.:15 kgs
 G.W.:16.4 kgs



UE-X010021

Professional Bumper Paint Stand

This is a professional paint stand for all kinds of bumpers;Can move freely with wheels;Two screw hooks on the stands(to hook fixed holes and fasten),below part has two fixed clips,left and right sides have anti distortion semicircle crown bar;all hooks,clips,and stand angles are adjustable.

Package Size: 1270x510x170 mm
 N.W.:21 kgs
 G.W.:22 kgs



UE-X010022

Engine Hood,panel,fender Paint Stand

This is a specified paint stand for engine hood, door panel,and fender,convenient and practical

Package Size: 1470x400x210 mm
 N.W.:22 kgs
 G.W.:23.5 kgs



UE-X010023

Bumper Polishing Stand

This stand can hold all kinds of bumpers by adjusting pipes and lifting bars;For polishing and painting;Special wheel design makes moving freely,and can enter into spray booth directly.

Package Size: 830x420x110 mm
 N.W.:14 kgs
 G.W.:14.5 kgs



UE-X010070

X Shape Locking Polishing Stand

This stand suits bumper polishing and other accessories short time placing.

Package Size: 128x620x100 mm
 N.W.:12 kgs
 G.W.:13.6 kgs



UE-X010071

Multilayer Bumpers Laying Stand



This is a realistic stand to store bumpers and other body kits, the distance from rack to rack is adjustable based on requests, sturdy and durable wheels make stands move freely in workshop, save space and make workshop more tidy and cleaner, it is a necessary equipment for professional auto painting work shops.

Package Size: 1230x300x190 mm
N.W.:31 kgs
G.W.:32.7 kgs



UE-X020001

Tire Rack(4 Tires)

Convenient for tires placing and application in daily repairing.

Package Size: 184X400X170 mm
N.W.:33 kgs
G.W.:35 kgs



UE-X020011

X Shape Laying Stand

This X shape stand is made of steel pipes which are bended and powder coated. Adjusting the chains over two sides makes different heights. The stand is covered with PU, which protects bumpers and windshields against scratching.

diameter 25 mm
thickness 2mm
Package Size: 1070x500x90 mm
N.W.:11.5 kgs
G.W.:12.8 kgs



UE-X020020

Removable Accessorier Washing Table

It is convenient for spare parts daily washing/assembly, with oil collecting pot.

Package Size: 1020x620x770 mm
N.W.:58 kgs
G.W.:60.8 kgs



Drawer for the selection of accessories



The lower level is a mobile platform.



UE-Q030015

Accident Vehicle Moving Dolly

Made of galvanized sheet by laser cutting and edge curving, assembled with heavy duty PU universal wheels. Left and right sides can be extended freely. Moving accident cars easily (front wheels and rear wheels damaged) Improving workshop utilization rate.

Material:
6mm galvanized sheet, 6inches universal heavy duty wheels;
Loading capacity: 2 ton
Package Size: 135x280x230 mm
N.W.:77 kgs
G.W.:79.6 kgs



UE-X030021
2 Ton

Accident Vehicle Single Moving Dolly

Made of 8mm angle steel by opposite angle welding;
Assembled with heavy duty PU universal brake casters;
Matched with 2 sets connectors with 3 methods to fix vehicles.

5 inches universal heavy duty casters
Loading capacity: 1.5 ton
Package Size: 460x590x530 mm
N.W.:76 kgs
G.W.:78.5 kgs



UE-F030023
1.5 Ton

Shortwave Infrared Curing Lamp



UE-SG1DS



UE-SG2DS

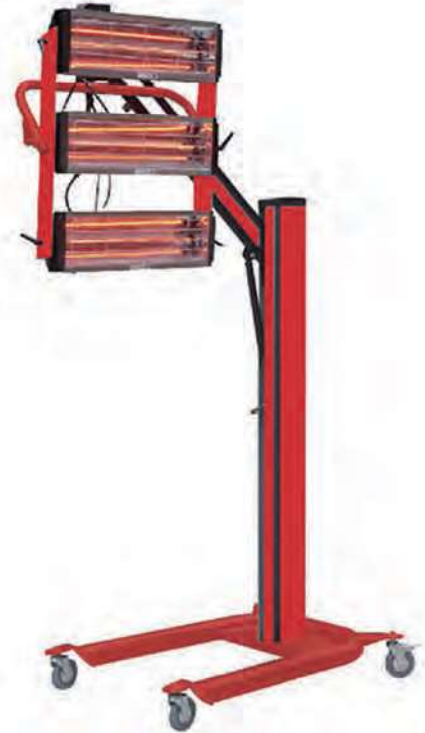

UE-SG3DA



UE-SG2D

- Made from Aluminum alloy, 304 stainless steel mirror reflector and other special material.
- Applying to drying the painting work for spot damage from the car body, avoiding the heating up the whole spray booth which highly reduce the cost
- Suitable for drying the spot damage under one area of three panels.
- Unique electronic timer, digital control system for half-power or full-power optional; Each emitter can be independently controlled.



UE-SG3D



Model	Input Voltage	Rated Power	Frequency	Rated Power	Adjustable Height	Preheating Time	Curing Distance	Working Current	Curing Temperature	Curing Area	Package Size (LxWxH)	N.W/G.W
UE-SG1DS	1PH110V/1PH220V	800W	50Hz/60Hz	800W	200-1500mm	1-5min	600-800 mm	4A	60-70 C	600X800 mm	485X445X265 mm	4kgs/6kgs
UE-SG2DS	1PH110V/1PH220V	2000W	50Hz/60Hz	2000W	200-1700mm	1-5min	600-800 mm	5-10A	60-70 C	800X800 mm	840X590X380 mm	21kgs/23kgs
UE-SG3DA	2PH220V	3000W	50Hz/60Hz	3000W	200-2500mm	1-5min	600-1000 mm	5-15A	60-70 C	800X1000 mm	1570X590X150 mm 1020X815X325 mm	13kgs /18kgs 23kgs / 28kgs
UE-SG2D	1PH110V/1PH220V	2000W	50Hz/60Hz	2000W	200-1500mm	1-5min	600-1000 mm	5-10A	60-70 C	800X800 mm	835X560X360 mm	21kgs/24kgs
UE-SG3D	2PH220V	3000W	50Hz/60Hz	3000W	200-2500mm	1-5min	600-1000 mm	5-15A	60-70 C	800X1000 mm	1570X590X150 mm 1020X815X325 mm	13kgs /18kgs 23kgs /30kgs

MIG/MAG Welder



1. Welding arc
2. Contact tip
3. Contact tip
4. Nozzle
5. Wire electrode
6. Melting pool
7. Solidified deposit

Description



UE-YD-MIG175



UE-YD-MIG205



Model	Main Voltage	Frequency	Input voltage	Input current	Rated input power capacity	Out-put current	No-load voltage	Electrode	Wire (mm)	N.W/G.W (kgs)	Package Size (mm)	QTY/20'CY (PCS)	MOQ
UE-YD-MIG175	220v	50/60 Hz	220V±15%	25.7	5.7	MIG-50-160 MMA:20-140	65±5	1.6-3.2	0.6/0.8	10/11	0.07	400	50
UE-YD-MIG205	220v	50/60 Hz	220V±15%	32.7	7.2	MIG-50-200 MMA:20-160	65±5	1.6-4.0	0.6/0.8/1.0	10/11	0.07	400	50

Automobile Spot Welder



UE-SG60L



UE-SG65L



UE-SG8500



UE-SG8900



UE-SG13000

Model	Input Voltage	Rated Power	Frequency	Floating Voltage	Welding Current	Max Output Power	Duty Cycle	Auto Working Time	Package Size (LxWxH)mm	N.W/G.W
UE-SG60L	2PH220V/380V	5KVA	50Hz/60Hz	6-11.5V	200-3800A	10.9KVA	15%	0.1-2.5s	490X400X660 mm	47 kgs/53 kgs
UE-SG65L	2PH220V/380V	5KVA	50Hz/60Hz	6-11.5V	200-4200A	11KVA	15%	0.1-2.5s	630X490X700 mm	55 kgs/64 kgs
UE-SG8500	2PH220V/380V	5KVA	50Hz/60Hz	6-12V	200-8500A	20KVA	15%	0.1-2.5s	580X440X920 mm	60 kgs/73 kgs
UE-SG8900	2PH220V/380V	5KVA	50Hz/60Hz	6-12.5V	200-8900A	20KVA	15%	0.1-2.5s	650X490X1020 mm	70 kgs/84 kgs
UE-SG13000	2PH220V/380V	5KVA	50Hz/60Hz	6-15V	200-13000A	25.5KVA	15%	0.1-2.5s	720X560X1020 mm	118kgs/134kgs

Battery Charger



CE

UE-YD-CD450



UE-YD-CB20

UE-YD-CB50



Model	Input voltage:	Input power frequency	AC power inPut	Rated charging current	Effective charging current	Charging voltage	Package Size (mm)	QTY/20'CY (PCS)	MOQ
UE-YD-CB20	AC220	50/60	300	18	12	6.56/7.56	0.05	560	100
UE-YD-CB50	AC220	50/60	1000	45	35	9.32/10.32	0.06	465	100
UE-YD-CD450	AC220	50/60	1600	50	40	16/17.4	0.09	310	50

Booster Cable



TUV GS CE

UE-WD0047

Specification	
Cable:	16MM2 200A
Length:	3 m
Package Size:	280X280X240 mm
QTY/CTN:	5 PCS
N.W/G.W PER CTN:	6/7 kgs
QTY/20'CY:	6800 PCS

TUV GS CE

UE-WD0048

Specification	
Cable:	25MM2 300A
Length:	3.5 m
Package Size:	310X310X260 mm
QTY/CTN:	5 PCS
N.W/G.W PER CTN:	9/10 kgs
QTY/20'CY:	5200 PCS

TUV GS CE

UE-WD0049

Specification	
Cable:	35MM2 400A
Length:	4.5 m
Package Size:	340X340X230 mm
QTY/CTN:	4 PCS
N.W/G.W PER CTN:	12/13 kgs
QTY/20'CY:	3850 PCS



Air Impact Wrench

- Twin Hammer mechanism.
- Directional smelting manufacture, light and durable, high power.
- Easy adjustable power regulator.
- Ideal for general repair on cars, tires, and heavy equipment



Model	Square	Free Speed (r.p.m)	Bolt Capacity (mm)	Max Torque (N.m)	Hammer Mechanism	Air Inlet	Air Pressure	Anvil Length	Moment Bound (N.m)	N.W. (kgs)	G.W. (kgs)	Package Size (mm)	QTY/CTN (PCS)	QTY/20'CY (PCS)	MOQ (PCS)
UE-ZM2811S	1/2"	8000	16	550	Twin Hammer	1/4"	6-8kgs/cm ²	1"	200-700	2.6	4.5	425x290x250	5	4000	100
UE-ZM2811	1/2"	8000	16	550	Twin Hammer	1/4"	6-8kgs/cm ²	1"	200-700	2.6	3.2	420x275x205	5	4000	100
UE-ZM3900S	1/2"	8000	18	900	Twin Hammer	1/4"	6-8kgs/cm ²	1"	200-750	2.1	4	425x330x300	5	3500	100
UE-ZM3900	1/2"	8000	18	900	Twin Hammer	1/4"	6-8kgs/cm ²	1"	200-750	2.1	2.6	420x215x255	5	3500	100
UE-ZM751	3/4"	5300	32	1450	Twin Hammer	3/8"	6-10kgs/cm ²	1.5"	600-1300	5.8	6.5	310x290x235	2	2600	100
UE-ZM780	1"	4600	33	1600	Twin Hammer	3/8"	6-10kgs/cm ²	1.5"	500-1400	7.3	8	310x290x235	2	2200	50
UE-FJ5040C	1/2"	8000	-	885	Twin Hammer	1/4"	6.5CFM	-	-	10.7	11.7	240x220x390	5	6430	500
UE-FJ040C	1/2"	9000	-	1085	Twin Hammer	1/4"	8.5CFM	-	-	13	14	240X220X390	5	6430	500

Heavy Duty Air Impact Wrench



UE-ZM550AL



UE-ZM550ALS

Model	Square	Free Speed (r.p.m)	Bolt Capacity (mm)	Max Torque (N.m)	Hammer Mechanism	Air Inlet	Air Pressure	Anvil Length	Moment Bound (N.m)	N.W. (kgs)	G.W. (kgs)	Package Size (mm)	QTY/CTN (PCS)	QTY/20'CY (PCS)	MOQ (PCS)
UE-ZM550AL	1"	4200	41	2500	Pinless Hammer	1/2"	8-12kgs/cm ²	8"	2900-1850	14	14.5	755X250X210	1	900	50
UE-ZM550ALS	1"	4200	41	2500	Pinless Hammer	1/2"	8-12kgs/cm ²	8"	2900-1850	18	18.5	660X300X170	1	900	50

Pneumatic Tools



UE-FJ5059F Air Ratchet Wrench

1/2" Air Ratchet Wrench
Square Drive: 1/2";
Free Speed: 160 rpm;
Max Torque: 90 Nm;
Avg. Air Consumption: 4cfm;
Weight: 1.22kg



Dual Action Air Sander

UE-FJ380F

6" Dual Action Air Sander
Sanding Pad: 6";
Free Speed: 10,000rpm;
Avg. Air Consumption: 5cfm;
Weight: 1.83 kgs

Model	N.W/G.W (kgs) Per CTN	Package Size (mm)	QTY/CTN (PCS)	QTY/20'CY (PCS)
UE-FJ5058F	12.1 / 13.1	320x290x160	10	18000
UE-FJ5059F	12.2 / 13.2	320x290x160	10	18000
UE-FJ7032F	7.9 / 8.9	310x205x255	20	33760
UE-FJ380F	20 / 21	440x380x340	10	4740
UE-FJ991F	11.1 / 12.1	630x240x335	10	5290

Air Tools Combo Kits



UE-FJ5040CK

15Pc 1/2" Composite Super Duty Air Impact Wrench Kit

1pc- 1/2" Composite Air Impact Wrench (NST-5040C);
8pc impact socket:
10, 11, 13, 14, 17, 19, 22, 24mm;
1pc- 1/2" DR. x 5" extension bar;
1pc-hex key;
1pc-1/4" male plug
1pc-mini oiler;
1pc-oil pot;
1pc-blow mold case

Model	N.W/G.W (kgs) Per CTN	Package Size (mm)	QTY/CTN (PCS)	QTY/20'CY (PCS)
UE-FJ5040CK	21 / 22	500x270x285	5	3550
UE-FJ7032FK	16.3 / 17.3	470x440x290	20	9000
UE-FJ019FK	24 / 25	480x260x275	5	3970
UE-FJ018FK	20 / 21	480x260x275	5	3970
UE-FJ050FK	18 / 19	440x290x370	2	1150



UE-FJ019FK

19Pc Air Tool Kit For Tyre Repair ;

19Pc Air Tool Kit For Tyre Repair ;
1Pc- 1/2" Composite Super Duty Air Impact wrench (NST-5040C);
1Pc- 1/4" Air Die grinder (NST-7032F);
1Pc- Tyre infalator with digital gauge;
4Pc- Impact Socket: 17, 19, 22, 24 mm;

5Pc- Grinding Stone;
3Pc- Male Plug;
1Pc-Oil pot;
1Pc-Teflon Tape;
2Pc- Hand Wrench;
1Pc-Blow Molded Case

Air Spray Guns



Equally, as well as being used as car paint sprayers, you can also use these as general purpose air compressor paint sprayers for other tasks you might have. So whether you're looking for gravity fed or suction fed spray guns, we're sure to have the perfect air spray gun amongst our product listings.

UE-WF990G1

UE-WF990G2

UE-WF990S

Model	Air Consumption(CFM) Cup Size(ML)	Cup Size (ML)	Nozzle Size (MM)		Fluid(Water) Delivery (ML/MIN)	Air Pressure (PSI)	Air Inlet (INCH)	N.W/G.W (kgs) Per CTN	Package Size (mm)	QTY/CTN (PCS)	QTY/20'CY (PCS)
			Standard	Range							
UE-WF990G1	3-8	600	1.5	1.2-2.5	160-240	43	1/4"	14/15	570x360x400	20	6800
UE-WF990G2	3-8	600	1.5	1.2-2.5	160-240	43	1/4"	15/16	570x360x400	20	6800
UE-WF990S	3-8	850	1.5	1.2-2.5	130-210	50	1/4"	9/10	570x350x295	10	4760
UE-WF4001	6-10	1000	1.8	1.4-2.5	160-240	50	1/4"	12/14	570x370x330	10	4020
UE-WF827S	6-10	1000	1.4	1.2-2.5	130-210	50	1/4"	12/14	760x235x270	10	5800
UE-WF828G	5-10	600	1.4	1.2-2.5	100-220	43	1/4"	15/16	680x460x260	20	6900
UE-WF6000AG	5-9	600	1.3	1.3-2.5	230-310	29-36	1/4"	10/12	680x340x245	10	4950
UE-WF601AS	6-10	1000	1.4	1.4-2.5	130-210	30-43	1/4"	12/14	795x415x240	10	3550
UE-WF801AG	6-10	600	1.3	1.3-2.0	150-230	29-36	1/4"	8/9	680x340x240	10	5050

Air Washing Gun



Model	N.W/G.W (kgs) Per Ctn	QTY/CTN(PCS)	Package Size(mm)	QTY/20'CY (PCS)
UE-WYA60-1	11/12	40	410x300x240	38000
UE-WYA60-2	12/13	40	410x300x320	28000
UE-WYA60-3	13/14	40	410x300x320	28000
UE-WYDO-10	12/14	20	590x440x420	5100
UE-WYDO-15	12/14	20	590x440x420	5100
UE-WYDO-9-EC	13/15	20	590x440x480	4400
UE-WYPS-1	11/13	10	380x300x350	7000
UE-WYPS-3	16/18	20	720x515x240	6200

UE-WYDO-10

Air Sandblast Gun



UE-WYPS-3



UE-WYPS-1

Air Hose Reel



UE-I03010Q
UE-I03011Q

UE-I03012Q
UE-I03013Q

Model:	UE-I03010Q	UE-I03011Q	UE-I03012Q	UE-I03013Q	UE-I03015Q	UE-I03020Q	UE-I03021Q	UE-I03030Q
Hose Length:	10*1M/33FT	14*1M/46FT	10*1M/33FT	20*1M/66FT	15*1.5M/50FT	20*2M/66FT	15*1.5M/50FT	30*2M/100FT
Hose Material:	□PVC □PU	□PVC □PU	□PVC □PU	□PVC □PU	□PVC	□PVC □PU	□PVC	□PVC □PU
Case Material:	PP	PP	PP	PP	PP	PP	PP	PP
Working Pressure:	18 Bar	18 Bar	18 Bar	18 Bar	18 Bar	18 Bar	18 Bar	18 Bar
Fitting:	□1/4"BSPT □1/4"NPT	□1/4"BSPT □1/4"NPT	□1/4"BSPT □1/4"NPT	□1/4"BSPT □1/4"NPT	□1/4"BSPT □1/4"NPT	□1/4"BSPT □1/4"NPT	□1/4"BSPT □1/4"NPT	□1/4"BSPT □1/4"NPT
Hose Size:	5/16"	1/4"	3/8"	5/16"	□3/8"	□3/8"	□1/2"	□3/8"
Gw/nm:	4.38/3.9KGS	4.38/3.9KGS	7.1/6.5KGS	7.1/6.5KGS	7.3/6.7KGS	10.35/9.6KGS	10.35/9.6KGS	13.25/12.4KGS
Packing Size(1pc):	295x165x330 mm	295x165x33 mm	320x200x340 mm	320x200x340 mm	440x225x410 mm	510x270x470 mm	510x270x470 mm	540x290x505 mm
Packing Size(1pc):	605x345x350 mm 4PC/CTN	605x345x350 mm 4PC/CTN	420x335x360 mm 2PC/CTN	420x335x360 mm 2PC/CTN	1PC/CTN	1PC/CTN	1PC/CTN	1PC/CTN
20'QTY:	1428PCS	1428PCS	1372PCS	1372PCS	690PCS	420 PCS	420PCS	360PCS
MOQ:	50PCS	50 PCS	50 PCS	50 PCS	50 PCS	50 PCS	50 PCS	50 PCS

Specification:

Suitable for different kind of solvent at same time
Double driving pump for higher cleaning efficiency
Two Separated tank with perfect welding seal
Solvent capacity:24 Gallon
Electrical requirement:110V,60Hz (240V/50Hz)



UE-G-PW40G-II
40 Gallon

Model: UE-G-PW40G-II
N.W.: 45 kgs
G.W.: 48 kgs
Package Size: 1140x550x330 mm
QTY/20'CY: 145 PCS

Parts Washer Trolley



UE-G4001-20M
20 Gallon

Model: UE-G4001-20M
N.W.: 34 kgs
G.W.: 37 kgs
Package Size: 850x570x500 mm
QTY/20'CY: 108 PCS



Portable Sandblaster



Model: UE-G4012
Overall Dimensions: 830x480x330 mm
Hose Length: 2500 mm
Work Pressure: 60-125 PSI
N.W.: 17 kgs
G.W.: 19 kgs
Package Size: 770x415x365 mm
QTY/20'CY: 233 PCS

Model: UE-G4020B
Overall Dimensions: 820x780x380 mm
Hose Length: 2500 mm
Work Pressure: 60-125 PSL
N.W.: 21 kgs
G.W.: 23 kgs
Package Size: 880x460x420 mm
QTY/20'CY: 160 PCS

UE-G4012
10 GALLON

UE-G4020B
20 GALLON



Model: UE-GA26
Hose Length: 16.4ft(5m)
Work Pressure: 65-125PSI
N.W.: 38.50 kgs
G.W.: 40.00 kgs
Package Size: 835x490x575 mm
QTY/20CY: 110 pcs
MOQ: 10 pcs

UE-GA26
26 GALLON

Vertical Sandblast Cabinet



UE-GA350

Model: UE-GA350
Overall Size: 950x700x1550 mm
Working Space: 885x673x660 mm
N.W.: 64.00 kgs
G.W.: 72.00 kgs
Package Size : 1050x775x780 mm
QTY/20CY: 40 pcs
MOQ: 10 pcs

UE-GA450

Model: UE-GA450
Overall Size: 1200x700x1500 mm
Working Space: 1285x775x780 mm
N.W.: 77.00 kgs
G.W.: 87.50 kgs
Package Size : 1285x790x77 mm
QTY/20CY: 24 pcs
MOQ: 10 pcs

Industrial Dust Collector

Function

This machine is designed for using with a sandblast cabinet, functioning as an auxiliary equipment to collect dusts generated during sand blasting.

- Power output:370W
- Motor Speed:2880 rpm
- Rate power:370W
- Rate current:2.73A
- Thickness of metal plate:1.2mm



UE-GA17

Model: UE-GA17
N.W.: 42.00 kgs
G.W.: 45.00 kgs
Package Size : 560x400x1100 mm
QTY/20CY: 112 pcs
MOQ: 10 pcs

Option



Plastic Oil Drains

Oil Drains



UE-GA35-B
35 L



UE-G2018
70 L

Model	Capacity (L)	Basin Capacity (L)	Working Pressure (psi)	Products Size (mm)	N.W/G.W (kgs)	Package Size (mm)	QTY/20'CY
UE-GA30	30L	10L	1-3Bar	400x400x1500	4,5 / 6	460x440x550	240
UE-GA35-B	35L	10L	1-3Bar	350x350x1500	5 / 6	460x440x550	240
UE-GA75	75L	10L	1-3Bar	450x450x1700	8 / 9	480x450x770	160

Model	Capacity (L)	Basin Capacity (L)	Working Pressure (psi)	Max Pressure (psi)	Products Size (mm)	N.W/G.W (kgs)	Package Size (mm)	QTY/20'CY
UE-YG2018	318Gallon / 70L	10L	8-10Bar	3Bar	480x350x1600	16 / 18	520x440x910	140
UE-G2020	18Gallon / 70L	10L	8-10Bar	3Bar	480x350x1600	16 / 18	520x440x910	140
UE-G2094	28Gallon / 105L	10L	8-10Bar	3Bar	500x500x1800	21 / 24	510x510x1120	90

Grease Injector

12L Manual GREASE INJECTOR
*Grease output:0.005 kg / one stroke
outlet Pressure:200-250 BAR, 2900-3625 PSI
Barrel Capacity:12 L*

UE-H12M-A
12 L



25L Manual GREASE INJECTOR
*Grease output:0.005 kg / one stroke
Outlet Pressure:200-250 BAR 2900-3625PSI
Barrel capacity:25 L*

UE-H25M
25 L



Model	Min.Qty (Sets)	Body Treatment	Packing	Qty/CTN (PC)	Meas(mm)	G.W./N.W (Kgs)	Qty/20'FT (PCS)
UE-H12M-A	100	Power Coating	Brown Carton	1	370x280x550	7.0 / 6.0	490
UE-H25M	100	Power Coating	Brown Carton	1	410x410x720	9.0 / 8.0	367

Manually Grease Gun



UE-SX467

- "Shift" switch to increase volume or pressure.
- Build-up with smart air vent valve for easy to release air pocket.
- Aluminum housing withstand tough environments.

UE-SX488N

Smart grease gun, its ideal for extending gun handle to allow one-hand operation grease gun to able worked in two-hand operation. By this way, the user could have more options to do its work in proper way. One-hand operation gun is convenience for narrow space. Two-hand operation grease is for user easy to get a high pressure performance. This smart "FUNCTION" gun offers a comfortable handle that lets you use one or two hands for greasing.



Dual Piston with 'high volume performance'

UE-SX479N

Model	Working Pressure Max(psi)	Burst Pressure(psi)	Delivers Mins (oz/Strokes)	Load ing Way (c.c.)	Capacity(c.c.)	N.W / G.W (kgs) Per CTN	Package Size(mm)	QTY/CTN (PCS)	QTY/20'CY (PCS)
UE-SX467	1000	2000	0.5 / 40	400	400	22.4 / 23.22	420x392x330	10	5400
UE-SX488N	3600	8000	0.8oz / 40	400	400	23.4 / 24.4	470x416x331	12	6000
UE-SX479	3600	6000	3oz / 40	400	400	23.98 / 26.97	585x415x285	16	6600
UE-SX460	4500	10000	1oz / 40	400	400	21.92 / 25.02	486x382x322	20	10000
UE-SX478	3600	6000	3oz / 40	400	400	23.98 / 26.97	585x415x282	16	6600
UE-SX220	2900	4000	0.5oz / 40	120	120	16.17 / 19.67	543x245x400	30	15000

Horizontal Jerrican



UE-YG-W5
5 L



UE-YG-W10
10 L



UE-YG-W20
20 L

Model	Thickness (mm)	Product size(mm)			N.W. (kgs)	G.W. (kgs)	Package Size (mm)	Pcs/ Ctn	MOQ (pcs)
		L	W	H					
UE-YG-W5	0.8	400	246	122.5	13.60	18.25	530x420x655	8	200
UE-YG-W10	0.8	395	245	187	13.20	16.20	530x415x630	6	200
UE-YG-W20	0.8	428	304	258	11.80	14.80	640x445x566	4	200

Foam Machine



UE-G25L2.0
25 L



Model	Description	Capacity (L)	Working Pressure (psi)	Max Pressure (psi)	Products Size (mm)	N.W/G.W (kgs)	Package Size (mm)	QTY/20'CY
UE-G25L2.0	25L multifunctional foam machine	6Gallon/25L	3Bar	8Bar	300x280x780	12/13	370x360x810	260
UE-G25LS	25L foam machine	6Gallon/25L	3Bar	8Bar	300x280x780	12/13	370x360x810	260
UE-G50L2.0	50L multifunctional foam machine	13Gallon/50L	3Bar	8Bar	380x360x800	17/19	440x420x810	200
UE-G5061	25L Stainless multifunctional foam machine	6Gallon/25L	3Bar	8Bar	300x280x780	10/11	370x360x810	260

Dry / Wet Vacuum Cleaner



UE-F30-G

Model	UE-F20-G	UE-F30-G	UE-F30-DG	UE-F30-HG	UE-F70-2P	UE-F70-3P
Tank Capacity	20 L	30 L	30 L	30 L	70 L	70 L
Rated Power(W)	1400 W	1400 W	1400 W	1400 W	2000 W	3000 W
Rated Voltage(V)	220-240 V	220-240 V	220-240 V	220-240 V	220-240 V	220-240 V
Nomal Frequency(Hz)	50 Hz / 60 Hz	50 Hz / 60 Hz	50 Hz / 60 Hz	50 Hz / 60 Hz	50 Hz / 60 Hz	50 Hz / 60 Hz
Vacuum suction(KPA)	>19 KPA	>19 KPA	>19 KPA	>19 KPA	>19 KPA	>19 KPA
Air flow	46 L / S	46 L / S	46 L / S	46 L / S	106 L / S	120 L / S
Accessory diametet(mm)	40 mm	40 mm	40 mm	40 mm	40 mm	40 mm
Length of cable(m)	5 m	5 m	5 m	5 m	5 m	5 m
Package	1 unit / carton	1 unit / carton	1 unit / carton	1 unit / carton	1 unit / carton	1 unit / carton
Conton dimension(cm)	40X45X58 cm	40X45X72 cm	40X45X72 cm	51X46X81 cm	63X59X100 cm	63X59X100 cm
NW/GW	10 / 11 kgs	11 / 12 kgs	11 / 12 kgs	11.5/13 kgs	24 / 28 kgs	26 / 31 kgs
Conveyance 40HQ	525 PCS	450 PCS	450 PCS	366 PCS	175 PCS	175 PCS
Moq:	50 PCS	50 PCS	50 PCS	50 PCS	20 PCS	20 PCS

High Pressure Washer



- Designed for home and semi-professional use, the Series are lightweight and compact pressure washer that's ideal for many outdoor cleaning jobs such as patios, garden furniture, bins, bikes and..



UE-Y1.1.0



UE-Y2.2.0



Model	Power	Rated Pressure	Max.Pressuer	Flow	Voltage	N.W. / G.W. (kg)	Package Size (mm)	QTY/20'CY (PCS)
UE-Y1.1.0S	1400W	70bar	105bar	5.0L/min	220-240/100-127V (50-60HZ)	5.6 / 6.6	260x250x445	1035
UE-Y1.1.0P	1600W	77bar	110bar	5.0L/min	220-240/100-127V (50-60HZ)	6 / 7.02	260x250x445	1035
UE-Y1.2.0S	1400W	70bar	105bar	5.0L/min	220-240/100-127V (50-60HZ)	5.8 / 6.8	290x250x445	920
UE-Y1.2.0P	1600W	77bar	110bar	5.0L/min	220-240/100-127V (50-60HZ)	6.1 / 7.1	290x250x445	920
UE-Y2.1.0S	1600W	77bar	110bar	5.0L/min	220-240/100-127V (50-60HZ)	6.35 / 7.35	290x250x445	920
UE-Y2.1.0P	1800W	80bar	120bar	5.0L/min	220-240/100-127V (50-60HZ)	6.55 / 7.55	290x250x445	920
UE-Y2.2.0S	1600W	77bar	110bar	5.0L/min	220-240/100-127V (50-60HZ)	7.4 / 8.4	290x250x660	633
UE-Y2.2.0P	1800W	80bar	120bar	5.0L/min	220-240/100-127V (50-60HZ)	7.75 / 8.75	290x250x660	633
UE-Y3.1.0S	2000W	100bar	150bar	6.0L/min	220-240/100-127V (50-60HZ)	8.2 / 9.2	335x320x503	543
UE-Y3.2.0S	2000W	100bar	150bar	6.0L/min	220-240/100-127V (50-60HZ)	9.4 / 10.4	335x320x705	330

Hot Air Gun

- Adjustable Temperature
- LCD Display



UE-GW1028
UE-GW1028A



- Removing Adhesive Labels, Thawing Pipes, Gutters, Freezers, or Radiators, Loosening Rusted Nuts and Bolts



Model	Voltage & Frequency	Rate Powerl	Temperature	Air Flow	N.W. / G.W.(kgs)	Package Size (mm)	QTY/CTN (PCS)	QTY/20'CY (PCS)
UE-GW1025	120V-60HZ	750/1500W	300/500°C	280/480 L/min	7/8.8	265x91x250	10	4040
UE-GW1026	230V/240V-50HZ	1000/2000W	350/550°C	300/500 L/min	9/10	265x91x250	10	4040
UE-GW1026A	120V-50HZ	750/1500W	300/500°C	280/480 L/min	9/10	265x91x250	10	4040
UE-GW1027	230V/240V-50HZ	2000W(Max)	50/50-550/50-550°C	350/350/500 L/min	9/10	265x91x250	10	4040
UE-GW1027A	100V/120V-60HZ	1500W(Max)	40/40-350/40-500°C	280/280/480 L/min	9/10	265x91x250	10	4040
UE-GW1028	230V/240V-50HZ	2000W(Max)	50/70-600/70-600°C	300/300/500 L/min	9/10	265x91x250	10	4040
UE-GW1028A	120V-60HZ	1500W(Max)	50/70-550/70-550°C	280/280/480 L/min	9/10	265x91x250	10	4040

Car Polisher

- Car waxing machine is mainly used for surface treatment of washing, beauty, wax and other high-grade products such as automobiles, aircraft, furniture and furniture.



UE-GW2006 UE-GW2006A



UE-GW2001



UE-GW2002

Model	Voltage & Frequency	NO LOAD speed	Pad Size	N.W. / G.W.(kg)	Package Size(mm)	QTY/CTN(PCS)	QTY/20'CY(PCS)
UE-GW2001	120V-60HZ	3500rpm	240mm/10"	2.0/2.2	260x245x220	6	1760
UE-GW2002	230V-50HZ	3500rpm	240mm/10"	2.0/2.2	265x245x225	6	1760
UE-GW2006	230V-50HZ	1800-3200rpm	240mm/10"	2.1/2.45	261x245x250	6	1576
UE-GW2006A	120V-60HZ	1800-3200rpm	240mm/10"	2.1/2.45	261x245x250	6	1576

Impact Wrench



UE-W-1000

Model	UE-W-1000
Rated Voltage(v)	230-240
Rated Input Power(w)	1010
No Load Speed(rpm)	2200
Max Torque(nm)	450
Size of Spindle(")	1/2
G.W(kgs)	22
N.W(kgs)	21
Package Size(mm)	480x390x315
Container(20"/40"/40"HQ)(pcs)	1936/3932/4608
MOQ(pcs)	500
QTY/CTN(pcs)	4



UE-W-550

Model	UE-W-550
Rated Voltage(v)	230-240
Rated Input Power(w)	520
No Load Speed(rpm)	3200
Forward(nm)	100
Reverse(nm)	320
Size of Spindle(")	1/2
G.W(kgs)	16.5
N.W(kgs)	16
Package Size(mm)	440x365x290
Container(20"/40"/40"HQ)(pcs)	2350/4950/5800
MOQ(pcs)	500
QTY/CTN(pcs)	4



LED Work Light

Material	Rubberized ABS	Lumens	250LM	
		4hrs		Over-charging & Discharging Protector
	Li-Ion	4hrs		Household Charger & 12V Car Charger
	USB cable			

N.W./G.W.:6.5/6.6 kgs
 Package Size:41x33.5x21 cm
 QTY/CTN:10 PCS
 QTY/20'CY:9680 PCS



UE-ZZ-836LED
 UE-ZZ-836SMD
 UE-ZZ-836COB



Material	ABS+PP	Lumens	250LM
	3WCOB	4hrs	
	Li-Ion	3hrs	
	USB		

N.W./G.W.:5/6 kgs
 Package Size:43x26x34 cm
 QTY/CTN:10 PCS
 QTY/20'CY:7360 PCS

UE-ZZ-8807



	3WCOB	Lumens	300LM
	4-6hrs		Over-charging & Discharging Protector
	3-6hrs		USB
	Household Charger & 12V Car Charger		Li-Ion

N.W./G.W.:3.5/4 kgs
 Package Size:40x20x20 cm
 QTY/CTN:20 PCS
 QTY/20'CY:17500 PCS

UE-ZZ-8831



	10W	Lumens	600LM	IP54
	SOS	3hrs		Over-charging & Discharging Protector
	Li-Ion	3-6hrs		Household Charger & 12V Car Charger
	USB cable			

UE-ZZ-510

N.W./G.W.:5/6 kgs
 Package Size:42x26x50 mm
 QTY/CTN:10 PCS
 QTY/20'CY:5120 PCS



Car Creeper



UE-6455 40"



Model	UE-6453	UE-6451	UE-6454A	UE-6503	UE-6452	UE-6455
N.W.:	5.76 kgs	6.14 kgs	6.3 kgs	7.4 kgs	7.2 kgs	6.8 kgs
G.W.:	6.58 kgs	6.94 kgs	7.0 kgs	8.4 kgs	8.35 kgs	7.7 kgs
Overall Size:	920x425x95 mm	920x425x95 mm	901x425x120 mm	1025x420x125 mm	1025x425x110 mm	1025x425x105 mm
Package Size:	935x450x110 mm	935x450x100 mm	485x485x185 mm	1040x440x90 mm	1050x440x130 mm	1060x450x120 mm
QTY/20'CY:	640 PCS	630 PCS	780 PCS	780 PCS	459 PCS	490 PCS

Plastic Car Creeper



Magnetic Parts Tray

UE-H6802-3 40"

Patent No.:
ZL201220005508.7



UE-H6808B 40"

Model	UE-H6803	UE-H6803B	UE-H6802-1	UE-H6802-2	UE-H6802-3	UE-H6808
N.W.:	3.45 kgs	3.83 kgs	4.98 kgs	5 kgs	5.29 kgs	4.5kgs
G.W.:	4.25 kgs	4.63 kgs	5.95 kgs	6 kgs	6.26 kgs	5.5kgs
Overall Size:	900x400x100 mm	900x400x100 mm	1010x475x130 mm	1010x475x130 mm	1010x475x130 mm	1010x480x100mm
Package Size:	930x420x80 mm	930x420x80 mm	1050x490x95 mm	1050x490x95 mm	1050x490x95 mm	1020x490x70mm
QTY/20'CY:	928 PCS	928 PCS	550 PCS	550 PCS	550 PCS	800 PCS

Creeper Seat

Model	UE-6208	UE-6340	UE-6100	UE-XDD250	UE-6301A
N.W.:	8.0 kgs	9.56 kgs	4.18 kgs	11 kgs	4.85 kgs
G.W.:	8.62 kgs	10.30 kgs	4.7 kgs	13 kgs	5.45 kgs
Overall Size:	445x445x450 mm	400x450x400 mm	364x365x365 mm	410X350X455 mm	400x367x383 mm
Package Size:	460x175x460mm	450x265x270mm	380x145x395mm	437x360x460 mm	410x390x260mm
QTY/20'CY:	800 PCS	840 PCS	1374 PCS	380 PCS	560 PCS
MOQ:				380 PCS	



UE-6100



UE-6301A



UE-XDD250

Tie Down / Tow Strap



Standard

UE-XS1100



Model	UE-XS14108	UE-XS11100	UE-XS12201H	UE-XS12305	UE-XS11100L	UE-XS11202S	UE-XS12201H	UE-XS13302H
Description	25mm x 1.8m Cambuckle Tie Down	25mm x 3m Ratchet Tie Down	25mm x 3.6m Ratchet Tie Down	25mm x 4.2m Ratchet Tie Down	1" (25mm) x 10' (3.0m) Ratchet Tie Down	1" (25mm) x 15' (4.5m) Ratchet Tie Down	1-1/16" (27mm) x 15' (3.6m) Ratchet Tie Down	1-1/2" (38mm) x 14' (4.27m) Nylon Padded Ratchet Tie Down
Safe Work Load	136kgs	250kgs	400kgs	500kgs	300lbs (136kgs)	500lbs (136kgs)	1000lbs (454kgs)	1867lbs (756kgs)
Break Strength	272kgs	500kgs	800kgs	1000kgs	900lbs (408kgs)	1500lbs (408kgs)	3000lbs (1363kgs)	5000lbs (2267kgs)
Qty/Pack	4	4	4	4	4	4	4	2
N.W.G.W	0.95/1kg	1.45/1.6kgs	3.1/3.3kgs	2.8/3kgs	1.45/1.6kgs	2/2.15kgs	3.1/3.3kgs	2.2/2.4kgs
Package Size	225x210x46mm	300x220x460mm	350x220x58mm	350x220x58mm	300x220x460mm	300x220x46mm	350x220x58mm	290x220x63mm
Qty/20'	7374PCS	6168PCS	4868PCS	4868PCS	6168PCS	6168PCS	4868PCS	5376PCS
MOQ	500PCS	500PCS	500PCS	500PCS	500PCS	500PCS	500PCS	500PCS



UE-XSS20119S

Model	UE-XS20301S	UE-XS20119S	UE-XS20106S
Description	2" (50mm) x 20' (6m) ATV Tow Strap with loop and hook end	2" (50mm) x 20' (6m) ATV Tow Strap with loop and hook end	2" (50mm) x 20' (6m) ATV Tow Strap with loop and hook end
Safe Work Load	666lbs (303kgs)	3000lbs (1363kgs)	5667lbs (2570kgs)
Break Strength	2000lbs (909kgs)	9000lbs (4080kgs)	17000lbs (7711kgs)
Qty/Pack	1	1	1
N.W.G.W	0.6/0.65kgs	1.4/1.5kgs	1.4/1.5kgs
Package Size	70x63x220mm	190x50x220mm	210x50x220mm
Qty/20'	2204PCS	10704PCS	9774PCS
MOQ	500PCS	600PCS	500PCS

Cable Puller

Multi-purpose tool: lifting, lowering, pulling, stretching.
Use anywhere: farming, gardening, machine shop, camping, boating, traveling, hobby shop, trucking, fencing, hunting, sports.

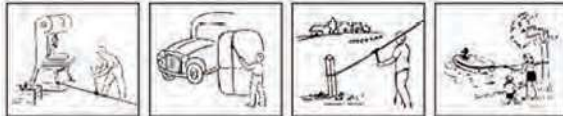

Model	UE-K8020	UE-8021CR	UE-K8041CR	UE-K8021	UE-K8041	UE-K8021L	UE-K8041L
Tractor Capacity:	2 Ton	2 Ton	4 Ton	2 Ton	4 Ton	2 Ton	4 Ton
Steel Cable Diameter:	Ø 4.8 mm	Ø 4.8 mm	Ø 5.5 mm	Ø 4.8 mm	Ø 4 mm	Ø 4.8 mm	Ø 5.5 mm
Steel Cable Length:	2.8 m	2.8 m	3 m	2.8 m	3 m	3 m	3.3 m
Package Size (mm):	605x315x180	590x280x220	710x210x290	605x315x180	710x280x210	645x305x250	755x250x165
N.W./G.W. (kgs):	2.3 / 2.7	2.6 / 2.9	5.35 / 5.95	2.9 / 3.05	5 / 5.5	3.2 / 3.5	5.75 / 6.75
QTY/CTN:	6 PCS	6 PCS	4 PCS	6 PCS	4 PCS	6 PCS	2 PCS
QTY/20' CY :	5160 PCS	5040 PCS	2560 PCS	5160 PCS	2560 PCS	3360 PCS	1400 PCS

Wire Rope Pulling Hoist



UE-T0800 800 kgs
UE-T1600 1600 kgs
UE-T3200 3200 kgs
UE-T5400 5400 kgs

Model	UE-T0800	UE-T1600	UE-T3200	UE-T5400
Rated forward handpower(N)	341	400	438	850
Rated capacity(kgs)	800	1600	3200	5400
Rope diameter (mm)	8.3	11	16	20
Rope size (m)	20	20	20	20
Max travelling load (kgs)	1200	2400	4000	8100
N.W. (kgs)	6.4	12	23	58
G.W. (kgs)	15.3	27	50.8	100
Max outer size (LxHxD mm)	426x238x64	545x284x97	660x325x116	930x390x150
Package size (mm)	960x760x790	1040x770x640	1060x770x610	1100x1100x720
QTY/CTN (PCS)	20	10	5	4
QTY/20' CY (PCS)	960	504	252	120



**Great For Atv's,
boats And Snow Mobiles**

Electric Winch



**UE-H99500-1
9500 LBS**

Model	Capacity (lbs)	N.W. (kgs)	G.W. (kgs)	Package Size (mm)	QTY/20'CY (PCS)
UE-H92000	2000	6	6.5	325x230x180	2000
UE-H92500	2500	7.5	8.1	340x290x170	1600
UE-H96000-1	6000	25	26	520x340x250	600
UE-H98000	8000	33.8	34.85	600x340x250	540
UE-H99500-1	9500	33	34	600x340x250	540

Electric Handy Winch

Model: UE-C9202
Capacity: 2000 LBS
N.W.: 8 kgs
G.W.: 9 kgs
Package Size:
315x260x225 mm
QTY/20'CY : 1200 PCS



**UE-C9202
2000 LBS**

Hand Winch

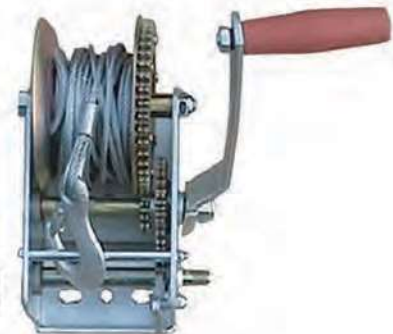

UE-T1060C 600 LBS
UE-T1101C 1000 LBS
UE-T1161C 1600 LBS
UE-T1201C 2000 LBS
UE-T1301C 3000 LBS

Model	UE-T1061C	UE-T1101C	UE-T1161C	UE-T1201C	UE-T1301C
Capacity	600 LBS	1000 LBS	1600 LBS	2000 LBS	3000 LBS
N.W. / G.W.(kgs):	13 / 15	18.5 / 20.5	16.5 / 18.5	20.5 / 22.5	02.5 / 22.5
Package Size(mm):	590x260x160	660x270x180	460x310x200	520x310x200	540x310x220
QTY/CTN:	6 PCS	6 PCS	4 PCS	4 PCS	4 PCS
QTY/20'CY:	1050 PCS	800 PCS	900 PCS	800 PCS	700 PCS

Model	UE-T1061S	UE-T1101S	UE-T1161S	UE-T1201S	UE-T1301S
Capacity	600 LBS	1000 LBS	1600 LBS	2000 LBS	3000 LBS
N.W. / G.W.(kgs):	11.5 / 13.5	16.5 / 18.5	14 / 16	18 / 20	20.5 / 22.5
Package Size(mm):	590x260x160	660x270x180	460x310x200	520x310x200	540x310x220
QTY/CTN:	6 PCS	6 PCS	4 PCS	4 PCS	4 PCS
QTY/20'CY:	1050 PCS	500 PCS	900 PCS	800 PCS	700 PCS



UE-T1060S 600 LBS
UE-T1101S 1000 LBS
UE-T1161S 1600 LBS
UE-T1201S 2000 LBS
UE-T1301S 3000 LBS

Chain Block



UE-C9005S
0.5 Ton

UE-C9010S
1 Ton

UE-C9020S
2 Ton



Patent Design
Heavy Duty Plastic Case

Model	Capacity (Ton)	Length of Chain (m)	N.W. / G.W. (kgs)	Package Size (mm)	QTY/20'CY (PCS)
UE-C9005S	0.5	2.5	8.7 / 9.6	370x155x250	1800
UE-C9010S	1	3	9.8 / 10.7	370x155x250	1800
UE-C9020S	2	3	13.2 / 14.1	370x155x250	1400

Chain Trolley



Model	Capacity (Ton)	Length of Chain (m)	N.W. / G.W. (kgs)	Package Size (mm)	QTY/20'CY (PCS)
UE-C9405	0.5	3	10 / 10.5	280x200x160	1628
UE-C9410	1	3	10.5 / 11	300x230x200	1368
UE-C9420	2	3	15.5 / 16	320x270x220	900
UE-C9430	3	3	22 / 22.5	335x310x260	633
UE-C9450	5	3	37 / 42	390x340x300	633
UE-C9500	10	3	78.5 / 89	480x440x410	202

Electric Chain Hoist

- Ideal for lifting heavy materials with minimum power.
- Triple spur gear.
- Safety hooks included.
- Safety brake prevents slipping.



ROHS / PAHS



Model	Hook	Capacity (kgs)	Rated Volt	Input Power (w)	Rated Lifting Weight (kgs)	Lifting Speed (m/min)	Lifting Height (m)	N.W/G.W (kgs)	Package Size (mm)	QTY/ CTN (pcs)	QTY/ 20'CY (pcs)	MOQ
UE-YT100	Single hook	100	220-240V	500	100	8	12	21.5/22	376x305x250	2	2000	50
	double hook	200			200	4	6					
UE-YT125	Single hook	125	220-240V	500	125	8	12	21.5/22	376x305x250	2	2000	50
	double hook	250			250	4	6					
UE-YT150	Single hook	150	220-240V	550	150	8	12	22/22.5	376x305x250	2	1900	50
	double hook	300			300	4	6					
UE-YT200	Single hook	200	220-240V	1000	200	8	12	33.5/34	415x330x270	2	1300	50
	double hook	400			400	4	6					
UE-YT250	Single hook	250	220-240V	1000	250	8	12	33.5/34	415x330x270	2	1300	50
	double hook	500			500	4	6					
UE-YT300	Single hook	300	220-240V	1050	300	8	12	34.5/35	415x330x270	2	1250	50
	double hook	600			600	4	6					
UE-YT400	Single hook	400	220-240V	1300	400	8	12	39.5/40	445x330x270	2	1150	50
	double hook	800			800	4	6					
UE-YT500	Single hook	500	220-240V	1600	500	8	12	32/33	555x245x355	1	600	50
	double hook	999			999	4	6					

Electric Chain Hoist

Shell: Light aluminum alloy shell shall be adopted which is light but hard and fit for the use in the terrible work environment with a high heat dissipation rate and all tightness design.

Inverse phase sequence protecting device: It is the special electrical installation which controls the circuit not to work in case of wiring error in the power supply.

Limit switch: The limit switch device is installed where the weight is lifted on and off to make the motor stop automatically so as to prohibit the chains from exceeding for safety.

24V/36V device: It is used to prohibit the emergencies from occurring in case of the leakage in the switch.

Side magnetic braking device: This device shall realize the instant brake in case of the power dump.

Chain bag: It shall be light, handsome and durable.

Chain: The chain shall adopt the imported FEC80 ultra heat-treatable Alloy steel chain.



UE-C9E0301B
3 Ton

Moving Trolley

Type	Capacity (Ton)	Speed 50Hz (m/min)	Motor (Kw)	Minimum radius of ture	QTY/20'CY (PCS)
UE-C9E0052	0.5	212.2 / 24	0.12	0.8	230
UE-C9E0102	1	11 / 21	0.4	0.8	160
UE-C9E0202	2	11 / 21	0.4	0.8	150
UE-C9E0302	3	11 / 21	0.75	1.0	140
UE-C9E0502	5	11 / 21	0.75	1.8	90
UE-C9E0752	7.5	11 / 21	0.75	2.5 (3.0)	80
UE-C9E1002	10	11 / 21	0.75	2.5 (3.0)	70



Type	Capacity (Ton)	Lifting Height (m)	Lifting Speed (m/min)	Lifting Motor					I-Beam (mm)	N.W./G.W. (kgs)	Package size (mm)	QTY/20'CY (PCS)
				Power (Kw)	Rotation Speed (r/min)	Phases	Voltage (V)	Frequency (Hz/s)				
UE-C9E0051B	0.5	3	6.8	0.8	1440	3	220/440	50/60	58-127	30/35	400x380x350	200
UE-C9E0101B	1	3	6.6	1.5	1440	3	220/440	50/60	68-130	61/68	600x350x330	150
UE-C9E0201B	2	3	6.6	3.0	1440	3	220/440	50/60	82-153	115/124	700x440x600	140
UE-C9E0301B	3	3	5.4	3.0	1440	3	220/440	50/60	82-153	131/142	700x440x600	125
UE-C9E0501B	5	3	2.7	3.0	1440	3	220/440	50/60	100-178	151/162	700x440x600	80
UE-C9E1001B	10	3	2.7	3.0x2	1440	3	220/440	50/60	150-220	300/330	950x700x860	36

Vehicle Bike Rack



UE-F2590B-F
Model: UE-F2590B-F
Package Size: 720x430x230 mm
N.W.: 4.5 kgs
G.W.: 4.7 kgs
QTY/CTN: 4 PCS
QTY/20'CY: 1500 PCS



Double Safety Lock

3 PCS Bikes



Model: UE-F2590
Product Size(WxDxH): 590x270x720 mm
Package: 100x260x170 mm
N.W.: 3 kgs
G.W.: 3.5 kgs
QTY/CTN: 6 PCS
QTY/20'CY: 4320 PCS

UE-F2590

Bike Carrier



UE-F2594
Model: UE-F2594
Package Size: 800x580x120 mm
N.W.: 4 kgs
G.W.: 5 kgs
QTY/20'CY: 500 PCS

3 PCS Bikes

Model: UE-F2599
Package Size:
780x385x190 mm
N.W.: 5.8 kgs
G.W.: 6.8 kgs
QTY/20'CY: 480 PCS



4 PCS Bikes



UE-F2599

Steel Bike Rack

UE-F51003



Model	UE-F51003
Capacity	30 kgs
Package Size	660x110x325mm
N.W / G.W	7.8 / 7.5 kgs
QTY/CTN	2 pcs
MOQ	1000 pcs



Steel Bike Rack

UE-F2871

UE-F2870

FEATURES:

Fully lockable roof bars suitable for cars with fitted side rails, such as SUVs and vans with roof bars. 52-1/2" bars can be cut to size as needed 132 lb. maximum load capacity across both bars. Quick and easy to fit and remove



Model	UE-F2871	UE-F2870
Capacity	15 kgs	15 kgs
Package Size	1475x260x155mm	1475x340x205mm
N.W / G.W	9 / 10.5 kgs	10 / 11 kgs
QTY/CTN	2 pcs	2 pcs
MOQ	500 pcs	500 pcs



Universal Dog Guard



UE-DR002

Package Size: 950x345x305 mm
 N.W.: 4 kgs
 G.W.: 4.5 kgs
 QTY/CTN: 4 PCS
 QTY/20'CY: 1100 PCS



UE-DR005-B

Package Size: 950x310x450 mm
 N.W.: 3 kgs
 G.W.: 4 kgs
 QTY/CTN: 6 PCS
 QTY/20'CY: 1260 PCS

Aluminum Folding Work Step



UE-T3001-1
200 kgs

Capacity: 200 kgs
 N.W.: 8.2 kgs
 G.W.: 9.5 kgs
 Package Size: 1020x385x185 mm
 QTY/CTN: 1 PC
 QTY/20'CY: 350 PCS



Auto Detailing



Household or shop projects

Coat Hanger

Suitable for suits, jackets, overcoat,...etc.
For traveling business people on the move.
Can be fitted to any head rest measuring 16mm or less.
Made of chrome-plated steel.



UE-Q20051

Width: 49 cm
Package Size:
1020x285x500 mm
N.W.: 0.75 kgs
G.W.: 0.9 kgs
QTY/CTN: 20 PCS
QTY/20'CY: 3800 PCS



UE-Q20052

Package Size:
485x180x55 mm
N.W.: 0.19 kgs
G.W.: 0.4 kgs
QTY/20'CY: 3800 PCS

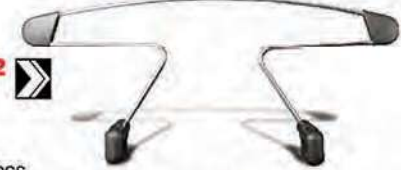

Tire Rack



UE-TAZ8253

Package Size: 712x724x76 mm
N.W.:15.3 kgs
G.W.:16.7 kgs
QTY/20'CY: 750 PCS

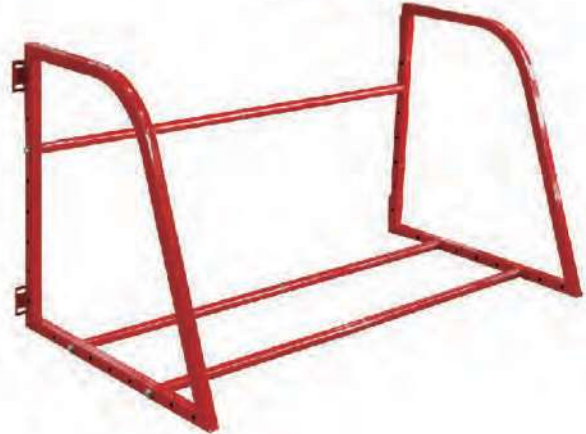

Wheel Step

Tire stepping for professional use automotive tools, there are two purposes: firstly, to increase the height of the installation of the roof support equipment to the roof, the second is for large SUV engine compartment operation easy reach inside. More convenient when working on are taller vehicle. Can be installed on the front and rear tires.



UE-TTC02

Package Size: 600x430x120mm
N.W. / G.W.: 5 / 5.5kgs
QTY/CTN: 1 PC
QTY/20'CY: 900 PCS
MOQ: 100 PCS

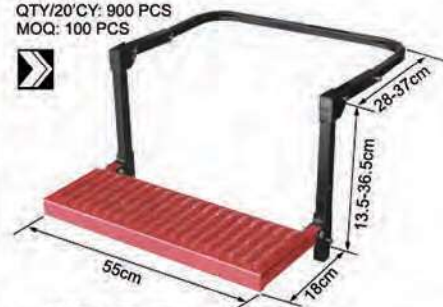

UE-TTC03

Package Size: 790x430x130mm
N.W. / G.W.: 6 / 7kgs
QTY/CTN: 1 PC
QTY/20'CY: 600 PCS
MOQ: 100 PCS



UE-F8402

Package Size:
545x315x485 mm
N.W.: 2.6 kgs
G.W.: 3 kgs
QTY/CTN: 10 PCS
QTY/20'CY: 3500 PCS



Polyester Cover
(Option)



Brake
Wheel



Foot Pump



UE-F892-C

Model: UE-F892-C
 Size: Ø55X100 mm
 N.W.: 15 kgs / CTN
 G.W.: 16 kgs / CTN
 QTY/CTN: 20 PCS
 Package Size: 390x260x370 mm
 QTY/20CY: 10000 PCS
 MOQ: 1500 PCS



Heavy Duty Air Compressor



LED Light

Model: UE-TH30A
 Power supply: DC12V, max rated current: 23A
 Max pressure: 150PSI
 Cylinder diameter: 30mm,
 Max. air flow: 45L/min
 Duration working time: 15 minutes
 Package Size: 550x340x430mm
 8 PCS/CTN: 21kgs
 QTY/20'CY: 2800 PCS
 MOQ: 50 PCS

UE-TH30A
 CE

Aluminum Loading Ramp



UE-F4501 200 kgs/pc

Load Capacity: 200 kgs/pc
 Dimensions: 1795x293x60 mm
 Package Size: 950x315x170 mm
 N.W.: 7 kgs
 G.W.: 8 kgs
 QTY/20'CY: 588 PCS

ALUMINUM

ATV Loading Ramp

ATV Loading Ramp provides you with a way to easily load and unload your ATV and power equipment in and out of the back of a pickup truck. These ramps make transporting your ATV a simple task and a non-skid surface ensures safety in all conditions.

Length: 2160 mm
 Folded Length: 1110 mm
 Width: 280 mm
 Load Capacity: 340 kgs/pc
 N.W.: 6.5 kgs
 G.W.: 7 kgs
 Package Size: 1130x290x300 mm
 QTY/CTN: 2 PCS
 QTY/20'CY: 560 PCS

ALUMINUM



UE-T7501 340 kgs/pc



ATV Loading Ramp

ATV Loading Ramp provides you with a way to easily load and unload your ATV and power equipment in and out of the back of a pickup truck. These ramps make transporting your ATV a simple task and a non-skid surface ensures safety in all conditions.

Length: 2260 mm
 Folded Length: 1160 mm
 Width: 295 mm
 Load Capacity: 340 kgs/pc
 N.W.: 7.2 kgs
 G.W.: 8.2 kgs
 Package Size: 1170x300x310 mm
 QTY/CTN: 2 PCS
 QTY/20'CY: 560 PCS

ALUMINUM



UE-T7502 340 kgs/pc



Vehicle Ramps



UE-TD2001G

2 TON

Capacity: 2 Ton/pair
 Max. Tyre Width: 210 mm
 Package Size: 865x320x910 mm
 N.W.: 5.6 kgs
 G.W.: 6 kgs
 QTY/CTN: 10 PCS
 QTY/20'CY: 900 PCS



2 in 1



UE-D1500A

Capacity:
 As loading ramp: 500 kgs per pair
 As car ramp : 1600 kgs
 Package Size: 610x340x280mm
 N.W.: 27.5kgs
 G.W.: 28.5kgs
 QTY/20CY: 480pcs

Geared Lug Wrench

The product with its 16:1 revolution ratio eliminates the hassle of tightening or loosening nuts of the cars.
 This product includes 17mm, 19mm and 21mm half inch sockets.



UE-X31005
Ratio: 1:16

Model: UE-X31005
 N.W.: 2.25 kgs
 G.W.: 2.37 kgs
 Package Size: 340x295x230 mm
 QTY/CTN: 4 PCS
 QTY/20'CY: 3600 PCS

Chrome Plated



UE-X31002
Ratio: 1:68
Change Truck Tire

Model: UE-X31002
 N.W.: 8.05 kgs
 G.W.: 8.25 kgs
 Package Size: 400x380x250 mm
 QTY/CTN: 4 PCS
 QTY/20' CY: 2200 PCS



Socket Size

Model: 17, 19, 21, 22, 24, 27, 30, 32, 33, 34, 36, 38, 41 mm



Ratio: 1:58
 Big Power Loose



Ratio: 1:3
 Quick Loose



Handle can remove



T-spark Plug Wrench

Model	Specs (mm)	G.W./N.W (mm)	Package Size (mm)	QTY/CTN	QTY/20'CY (PCS)	MOQ
UE-XTP02	16	0.24/0.22	410x270x190	50	70000	100
UE-XTP05	21	0.26/0.24	410x270x220	50	60000	100
UE-XTH02	16	0.24/0.22	410x270x200	50	65000	100
UE-XTH05	21	0.26/0.24	410x270x220	50	60000	100
UE-XTS02	16/21	0.38/0.4	460x280x210	50	55000	100

UE-XTP02
UE-XTP05



Lug Wrench



UE-TRX31101
(03.1101)

Model	Specs (mm)	G.W. / N.W. (kgs)	Package Size (mm)	QTY/CTN (PCS)	QTY/20' CY (PCS)	MOQ (PCS)
UE-X31101B	14" ∅ 16x355	26 / 25	330x290x360	20	13140	50
	16" ∅ 16x406	28 / 27	370x320x360	20	12200	50
	20" ∅ 16x500	35 / 34	430x390x360	20	9360	50
UE-X31101	14" ∅ 16x355	26 / 25	330x290x360	20	13140	50
	16" ∅ 16x406	28 / 27	370x320x360	20	12200	50
	20" ∅ 16x500	35 / 34	430x390x360	20	9360	50
UE-X31201	14" ∅ 16x355	27 / 26	380x310x180	20	12660	50
UE-X31301	14" ∅ 16x355	27 / 36	350x290x360	20	12660	50
	15" ∅ 16x380	29 / 27	370x310x360	20	11780	50

2-in-1 Lug Wrench

UE-X83378



Model	Specs (mm)	G.W. / N.W. (kgs)	Package Size (mm)	QTY/CTN (PCS)	QTY/20' CY (PCS)	MOQ (PCS)
UE-X83375	17/19/21/23	14.4/15.6	470x310x270	12	7800	100
UE-X83378	17/19/21/23	13/14	410x200x120	10	13000	100



UE-JY-1111 4"
UE-JY-1113 6"
UE-JY-1114 7"



UE-JY-1151L 4"
UE-JY-1153L 6"
UE-JY-1154L 8"



Model	Specifi	Opening (mm)	Clamping Force (Kgs)	Qty/ctn (Pcs)	N.W./G.W. (Kgs)	Package Size (mm)	MOQ
UE-JY-9122	4"	65-75	600	1	6.5/6.0	305x130x180	300
UE-JY-9124	6"	110-125	1000	1	13/12	345x220x200	300
UE-JY-9125	8"	125-150	1000	1	19/18	410x210x220	300
UE-JY-1151	4"	102	1000	1	11.5/10.5	370x180x200	300
UE-JY-1153	6"	153	1500	1	21.5/20	450x210x240	300
UE-JY-1154	8"	200	2000	1	32/30	560x270x280	300
UE-JY-1081	4"	75	900	1	6/5	300x200x310	300
UE-JY-1083	6"	125	1500	1	16/14.5	360x350x210	300
UE-JY-1111	4"	100	1000	1	10/9	340x320x220	300
UE-JY-1113	6"	150	1500	1	20/19	460x210x260	300
UE-JY-1114	7"	178	1800	1	24/23	480x230x290	300
UE-JY-8133	5"	100-125	1800	1	30/28	470x250x240	300

Model	Specifi	Opening (mm)	Clamping Force (Kgs)	Qty/ctn (Pcs)	N.W./G.W. (Kgs)	Package Size (mm)	MOQ
UE-JY-1151L	4"	100	900	1	8/7	290x150x150	300
UE-JY-1153L	6"	150	1200	1	16.5/15	360x180x200	300
UE-JY-1154L	8"	200	1500	1	23/21	440x190x220	300
UE-JY-1001	3"	95	1500	1	6.5/5.5	280x140x150	300
UE-JY-1003	4"	140	2200	1	20/19	410x200x210	300
UE-JY-1005	6"	195	3000	1	32/31	530x300x250	300
UE-JY-1006	8"	230	3100	1	39/37.5	580x310x280	300
UE-JY-8372	7kgs	n/a	n/a	1	7.5/7	240x140x150	300
UE-JY-8373	11kgs	n/a	n/a	1	11.5/11	260x150x170	300
UE-JY-8374	25kgs	n/a	n/a	1	26/25	380x220x220	300
UE-JY-8375	35kgs	n/a	n/a	1	36.5/35	410x220x210	300
UE-JY-8376	50kgs	n/a	n/a	1	52/50	470x240x230	300

23 Piece Hydraulic Puller Set



UE-K203D



Separator Set 7.5-10 Ton Capacity Hydraulic Ram with Tommy Bar. Suitable for Agricultural machines. Garage and Industrial Use.

Model	UE-K203D
N.W. (kg)	16.6 kgs
G.W. (kg)	17.3 kgs
Package Size(mm)	455x300x100 mm
QTY/20'CY	607 PCS

Contents

- Hydraulic Ram 7.5-10 Ton 1 PC
- Hydraulic Ram Center Bar 1 PC
- 1x50 mm Ram Extension 1 PC
- 1x100 mm Ram Extension 1 PC
- Puller Ram (4" 3 PCS), (6" 3 PCS), (8" 3 PCS)
- Triple Head for Puller 1 PC
- Twin head 1 PC
- Grooved Center Nut 1 PC
- Head for Puller 1 PC
- Pulling Bolt for Device with Nut 2 PCS
- Pulling Bolt Extension 2 PCS
- 4" Separator 1 PC
- Metal Box 1 PC
- Weight 18 kgs

Slide Hammer Puller Kit

For Internal & External Pulling, 3 Jaws Exchangeable, 4 PCS Set



UE-K201B

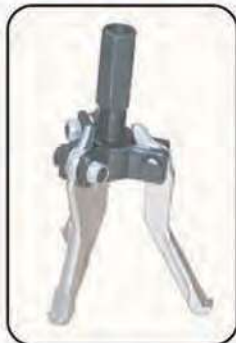

Model	UE-K201B
Internal Dia (mm)	15-30 / 30-80
External Dia (mm)	15-80
N.W. / G.W. (kg)	25 / 27
Package Size (mm)	440x400x140
QTY / CTN (PCS)	5
QTY / 20'CY (PCS)	3100

Adjustable Hydraulic Gear Puller

360 Degree Rotatory Pump Handle, Integral Safety Vavel, Chrome Vanadiumplated, with Spring Draw Back.

This hydraulic gear puller is great for hard to handle jobs and includes a attached portable pump. The jaw clamps can be used in 2 or 3 jaw configurations and can be adjusted from large and small clamping. The puller has a center point for easy alignment. Also features a 360 degree rotating handle.



UE-K208

Model	Capacity	Spread (mm)	Stroket (mm)	Jaws	N.W. / G.W. (kg)	Package Size (mm)	QTY/20'CY (PCS)
UE-K208	5 Ton	200	60	2/3	7.5 / 7.8	450x165x130	2250
	10 Ton	250	80	2/3	12 / 12.3	450x165x150	1400
	15 Ton	350	80	2/3	16 / 16.5	480x165x180	1100
	20 Ton	400	80	2/3	17 / 17.5	480x165x180	1000
	30 Ton	450	90	2/3	22.5 / 24.5	485x210x195	200
	50 Ton	600	100	3	39.5 / 48.3	605x330x310	300

Engine Tools

PROFESSIONAL GRADE

UE-HS-2518

Crankshaft—Camshaft seal remover and installer kit



- N.W/G.W: 8/9 kgs
- QTY/CTN:2 PCS
- PACKAGE:460x380x200 mm

Contents

Quick and easy work for both removal and installation work
Ideal for both crankshaft and camshaft seal
Master kit includes wide size seal installers
Provided with 2 seal removers with different length and angle fits wide applications
Angled blade seal remover is ideal for removing seals in limited space

- MOQ:10 PCS

UE-HS-2570

7Pcs Sensor Socket Set



- N.W/G.W:21/22 kgs
- QTY/CTN:10 PCS
- PACKAGE:560x240x200 mm

Contents

Special socket for removing oxygen Sensor Include:
1/2" Drx29mmx90mmL(7mmslot)
1/2" Dr x27mm(12pt) x82mmL
3/8" Dr x7/8" x 90mmL(20mm slot)
3/8" Drx 1-1/16" x74mmL
3/8" Dr. x 7/8" x80mmL
1/2" Dr x 22mmx50mmL
3/8" Dr x22mmx31mmL

- MOQ:10 PCS

UE-HS-3206

Press and pull sleeve kit 27pcs



- N.W/G.W:18/19 kgs
- QTY/CTN:1 PCS
- PACKAGE:470x420x120 mm

Contents

22x press-on sleeves, inside Diameter 34,36,38,40,42, 44,46,48,50,52,54,56,58,60,62,64,66,68,70,72,75,80mm
Outside Diameter:44,46,48,50,52,54,56,58,60,62,64,66, 68,70,72,74,76,78,80,82,85,90mm
5xpulling spindle nuts, Sizes:M10 M12 M14 M16 M18

- MOQ:10 PCS

UE-HS-4039

17pcs wheel drive bearing service kit



- N.W/G.W:17/18 kgs
- QTY/CTN:50 PCS
- PACKAGE Size:540x180x320 mm

Contents

Comprehensive set for the removal and installation of front hub bearings.
Without the need to dismantle the steering assembly.
Hub Screws - M12 x 1.5 and M14 x 1.5mm.
Drift sizes - 55,5, 59, 62, 65, 66, 71,5, 73, 78, 84, 86, 91mm.
Suitable for most front wheel drive cars and vans.

- MOQ:50 PCS

UE-HS-3265

22 PCS Wheel Locking Key Set For BMW



- N.W/G.W:20/21 kgs
- QTY/CTN:50 PCS
- PACKAGE Size:390x270x260 mm

Contents

Set of twenty locking keys for the removal of locking wheel
#41, #42, #43, #44, #45, #46, #47, #48, #49, #50, #51, #52, #53, #54, #55, #56, #57, #58, #59, #60
1/2"Dr. 19mm(HEX) 42mm(L) key socket
Release tommy bar

- MOQ:50 PCS

UE-HS-4037

23Pcs wheel wheel bearing removal tool kit



- N.W/G.W:10.5/11.5 kgs
- QTY/CTN:1 PCS
- PACKAGE:450x310x105 mm

Contents

This set reduces the chance of damage to hub and bearing
Also suitable for removing and installing large industrial bearing
Drive shaft:32 & 38mm
Drift size:50,55,60,64,67,70,72,74,75,78,82,88mm

- MOQ:10 PCS

UE-HS-A1020C

TU-15 Cylinder Pressure Meter for Diesel Truck



- A comprehensive kit for testing the compression on both petrol and diesel vehicles.
- Features 600psi gauge with large rubber bumper, straight and right angled quick connect fittings and an extensive range of spark/glow plug and injector adaptors.
- This kit will cover most modern car, van, truck, bus, agricultural and marine engines.
- Spark Plug Sizes: 10, 12, 14, 18mm.
- Glow Plug Adaptors: Alfa Romeo, BMW, Chrysler, Citroen, Daewoo, Fiat, Ford, Honda, Hyundai, Isuzu, Jeep, Kia, Lada, Lancia, Land Rover, LDV, Mazda, Mercedes, MG, Mitsubishi, Nissan, Peugeot, Renault, Rover, Saab, Ssangyong, Suzuki, Toyota, VAG, Vauxhall, Volvo.
- Injector Adaptor: M20, M22, M24 & Ford Stanadyne injectors plus clamp-on injectors.
- N.W./ G.W.: 4.8 kgs / 5 kgs
- Package Size: 440x440x345 mm
- QTY/CTN: 5 PCS
- MOQ: 10 PCS

UE-HS-A1000

Unique Compression



- Easy-reading 2-1/2" diameter gauge, features colour-coded quadruple, calibrations with 0-300psi, 21kg/cm, 21bar & 2100kpa.
- 13" durable rubber hose with 14mm / 18mm adaptor.
- 6" heavy-duty stem with universal rubber cone adapter fits all plug holes.
- N.W./ G.W.: 0.7 kgs / 0.75 kgs
- Package Size: 560x330x220 mm
- QTY/CTN: 20 PCS
- MOQ: 20 PCS

UE-HS-A1020B

TU-15 Cylinder Pressure Meter for Diesel Truck



- With all the adaptor for diesel engine in the world.
- N.W./ G.W.: 3.4 kgs / 3.8 kgs
- Package Size: 395x295x410 mm
- QTY/CTN: 5 PCS
- MOQ: 10 PCS

No.	Item	Length	Thread
1	Glow plug adaptor	91 mm	M10x1
2	Glow plug adaptor	119 mm	M10x1
3	Glow plug adaptor	135 mm	M10x1.25
4	Glow plug adaptor	118 mm	M22x1.5
5	Dial gauge	340 mm	/
6	Glow plug adaptor	113 mm	M10x1
7	Glow plug adaptor	102 mm	M8x1
8	Glow plug adaptor	83 mm	M10x1
9	Glow plug adaptor	67 mm	M10x1.25
10	Glow plug adaptor	51 mm	M12x1.25
11	Screw adaptor	160 mm	M18x1.5
12	Injector adaptor	88 mm	M24x1.5
13	Injector adaptor	75 mm	M22x1.5
14	Injector adaptor	63 mm	M24x2
15	Injector adaptor	75 mm	M20x1.5
16	H fitting	/	/
17	Bleed valve	/	/

UE-HS-A1014

Automatic Wave-box Pressure Meter



- Easy to read dual scale gauge. Complete with 24"(600mm) of oil proof hose with 1/8" NPT.
- Also includes 1/4" NPT and 3/8" NPT adaptors.
- Dual gauge readings: 0 to 500psi (0 to 35 bar)
- Gauge diameter: 3"
- N.W./ G.W.: 1.3 kgs / 1.4 kgs
- Package Size: 470x360x340 mm
- QTY/CTN: 10 PCS
- MOQ: 20 PCS

UE-HS-A0032

Combination Electronic Stethoscope Kit (6 Channel)



- Super-sensitive stethoscope with rubber cone and test probe. Suitable for detection of faults in: Engine, Transmission, Cat Intake/Exhaust Manifold, Fuel Injectors, Radiators, Valves, Fuel Tanks.
- Kit includes audio probe, headphones, four clip-on microphones and four channel microphone selector boxes. Used by Noise, Harshness and Vibration engineers can isolate problem sources. Enables vehicle to be road-tested and diagnosed simultaneously.
- N.W./ G.W.: 3 kgs / 3.33 kgs
- Package Size: 430x330x410 mm
- QTY/CTN: 3 PCS
- MOQ: 12 PCS

UE-HS-4046

Valve Seal Remover and Installer Kit



- N.W/G.W: 9/10 kgs
- QTY/CTN: 10 PCS
- PACKAGE: 340x290x270 mm

Contents

11pc Valve Seal Remover And Installer Kit For Removal Of Valve Stem Seals On Overhead Camshaft Engines
Valve Pliers Reach Down Around The Valve Stem Into The Confined Areas Of The Seal To Grip It For Removal / Installation
Knurled Ends On The Adapters Provides Maximum Grip In Oily Conditions

- MOQ: 10 PCS

UE-HS-1004

4Pcs Spark Plug Puller Set-VAG



- N.W/G.W: 11/12 kgs
- QTY/CTN: 10 PCS
- PACKAGE: 400x310x330 mm

Contents

Suitable for installation/Removal of ignition coils on VAG vehicles
Long Shafts with composite T-style handle for added control and stability
Prevents damage to ignition coils whilst allowing faster removal

- MOQ: 10 PCS

UE-HS-A3414

Engine Compression Tester Set



- Adaptive Inside: 10x1, 12x1.25, 14x1.25, 18x1.5.
- M10xM18 Screw repair driver
- M14xM18 Screw repair driver
- N.W./ G.W.: 2 kgs / 2.2 kgs
- Package Size: 530x340x315 mm
- QTY/CTN: 5 PCS
- MOQ: 10 PCS

UE-HS-1064

16Pcs Glow Plug Removal Set



- N.W/G.W: 18/19 kgs
- QTY/CTN: 10 PCS
- PACKAGE: 400x310x320 mm

Contents

This set includes

Top connection removal tool star socket
Allen key
Dual-size high-tensile step drill M8 & M10
Pilot drill centring sleeves
Pilot drill 3.5mm
Tap: 1/4", M8, M10
Puller adaptor mandrels

- MOQ: 10 PCS

UE-HS-1083

17pcs Diesel injector seat cutter set

- N.W: 10.5 kgs
- G.W: 11.5 kgs
- Package Size: 330x310x235 mm
- Qty/CTN: 5 PCS



Contents

14mm x 14mm Flat Reamer
15mm x 19mm Flat Reamer
15.5mm x 15.5mm Flat Reamer
15.5mm x 15.5mm Angled Reamer
17mm x 17mm Angled Reamer
17mm x 17mm Flat Reamer
17mm x 17.5mm Flat Reamer
17mm x 19mm Flat Reamer
17mm x 19.5mm Flat Reamer
17mm x 20mm Flat Reamer
17mm x 21mm Angled Reamer
17.5mm x 20.5mm Angled Reamer
19mm x 21.5mm Flat Reamer T-handle Pilot Hex 19 x 170mm 15.5 X 250mm
Cutter 2.5mm Hex Key

- MOQ: 10 PCS

Cooling System And A/C Tools

PROFESSIONAL GRADE

UE-HS-A3306

27 PCS Radiator Pressure Tester Vacuum-Type Cooling System Kit



- 0 to 35 psi gauge range
- Adapters usable with most of domestic and imported cars
- Durable product design and unexcelled precision of tools
- Complete, all-in-one set allows quick and easy testing for leakage in radiator and prompt change of coolant
- 19 color coded radiator test caps
- N.W./ G.W.: 6 kgs / 6.33 kgs
- Package Size: 600x315x50 mm
- QTY/CTN: 3 PCS
- MOQ: 15 PCS

UE-HS-A3310

Water Tank Leak Detector (14 PCS)



- Test cooling system for leaks.
- Includes hand pump, test head in a blowmold case.
- Suit for: Mitsubishi, Mazda, Subaru, Toyota, Honda, Ford GM, Chrysler, VW, Audi, Volvo, Saab, Mercedes Benz, BMW, Renault, Fiat, Alfa, Romeo, Infiniti, Geo, Suzuki, Isuzu, Lexus, Opel, Peugeot, Jeep, Rover, Citroen, Truck.
- N.W./ G.W.: 4 kgs / 4.3 kgs
- Package Size: 400x330x410 mm
- QTY/CTN: 3 PCS
- MOQ: 12 PCS

UE-HS-1051B

Product Description



- N.W/G.W.: 2.8/3.8 kgs
- QTY/CTN: 20 PCS
- PACKAGE Size: 320x310x90 mm

Contents

1. Refrigeration Tools of Manifold Gauge for Air Conditioning System for R134A R404A R22 R410A Unique biphenotypic valve

The gasket seal adopts the most popular environmental protection material can live up to eight years the high pressure is 0-800psi, low pressure 0-500psi with 3pieces 1.5m long hose and 3000psi max explosion pressure pack with 2pcs stright coupler, 1pcs multifunction bottle opener, 1pcs valve tools, 1bag oil seal ring

- MOQ: 20 PCS

UE-HS-C1051A

R134A A/C Manifold Gauge Set (60", adjustable)



- Inclosed the 1107adjustable coupler.
- R-134a sight glass manifold with three 60" color-coded hoses.
- With sight glasses.
- High pressure: 0-500psi
0-35Kg/cm²
- Low pressure: 0-120psi
-1-8.5Kg/cm²
- Vacuum: 0-30 in/Hg
- N.W./ G.W.: 1.75 kgs / 1.85 kgs
- Package Size: 635x315x460 mm
- QTY/CTN: 10 PCS
- MOQ: 10 PCS

UE-HS-3408

Product Description



- N.W/G.W.: 4.3/5.3 kgs
- QTY/CTN: 20 PCS
- PACKAGE Size: 400x380x100 mm

Contents

EFI Model:

1. Find out the fuel return hose, disconnect it and plug it with suitable adaptor;
2. Find out the fuel inlet hose, disconnect it and connect it with the outlet hose of the cleaner with proper adaptor;
3. Connect the outlet and return hose of the fuel tank, and open the tank cover; if there is not return hose, please move the fuse of the fuel pump so that the pump will not work;
4. Charge the cleaning fluid into the tank of the cleaner;
5. Connect the air source power to the air port of the cleaner, adjust its pressure 40-50PSI;
6. Check all connect point to make sure there is not leakage;
7. Start the engine to clean the fuel system.

To the Throttle Style:

To the throttle style system, the way of connection is the same, just adjust the pressure of the air source 1-5PSI.

The way to identify the inlet and return hose:

1. Generally speaking, inlet hose is bigger, return hose is smaller;
2. There is always a filter connected in the inlet hose side, and a buffer in the return side;
3. There is arrow on the hose to show the fuel flow direction.

- MOQ: 20 PCS

UE-HS-1052

Product Description



- N.W/G.W.: 1.2/2.2 kgs
- QTY/CTN: 20 PCS
- PACKAGE Size: 300x300x300 mm

Contents

Features:

100% brand new and high quality.
A/C Manifold Gauge tester & 3 color-coded refrigeration charging hoses.

Red & blue Manifold Gauges, clear dials, vivid scales, equipped with sight glass, easy to read.

Designed for using on automotive/family air conditioning system.

Available for R134A, R12, R22 & R502 refrigerants.

High pressure valve contributes to secure connect fittings.

This manifold gauges tools set services for diagnosing and recharging any A/C systems.

A solid hook for hanging the gauges to save space.

Specification:

Material: Copper + Plastic

Total weight: about 1.15 kg

Hose length: about 90 cm

Components: Double table valve + Three Colored-hoses +

Balance hook(as pictures shown)

Package Included:

1x Manifold Gauges Tools Set

- MOQ: 20 PCS

Brake And Clutch Tool

PROFESSIONAL GRADE

UE-HS-E3501

Clutch Tool Set



- Necessary for pre-tensioning self adjusting clutches before removal installation
- Prevents plate distortion which may prevent the clutch from disengaging or cause dragging.
- Features a refitting tool, allowing the clutch adjuster to be wound back, and six alignment adaptors.
- Alignment adaptor sizes: $\Phi 15/23$ mm, $\Phi 15/28$ mm, $\Phi 15/34$ mm, $\Phi 21/23$ mm/ $\Phi 20/23$ mm, $\Phi 14&15/20$ mm
- Assembly flywheel threads: $\Phi 6 \times 1.00$ mm, $\Phi 7 \times 1.00$ mm, $\Phi 8 \times 1.25$ mm
- N.W./ G.W.: 5.1 kgs / 5.3 kgs
- Package Size: 385x330x300 mm
- QTY/CTN: 2 PCS
- MOQ: 10 PCS

UE-HS-E3318A

Universal Caliper Wind Back Kit



- Winds back brake piston for replacing brake pads.
- Applications: Audi, BMW, Ford, Honda, Jaguar, Mazda, Mercedes, Mitsubishi, Nissan, Saab Subaru, Toyota, VW.
- N.W./ G.W.: 1.9 kgs / 2 kgs
- Package Size: 470x370x335 mm
- QTY/CTN: 10 PCS
- MOQ: 10 PCS

UE-HS-E3318B

Positive & Negative Caliper Wind Back Kit



- Master set of adaptors for a wide range of vehicle applications.
- Suitable for push back and wind-back brake pistons.
- Includes left and right handed thrust bolt assemblies.
- Left handed thrust bolt required for Ford, Citroen and Renault applications.
- Precision made adaptor plates with thrust bolt assembly and reaction plate.
- Updated adapter set suitable for a wide variety of UK Vehicles.
- Applications: Alfa Romeo, Audi, BMW, Citroen, Fiat, Ford, GM, Honda, Jaguar, Mazda, Mercedes, Mitsubishi, Nissan, Opel, Peugeot, Renault, Rover, Saab, Seat, Skoda, VW, Volvo, Subaru, Toyota, Vauxhall.
- N.W./ G.W.: 2.1 kgs / 2.2 kgs
- Package Size: 470x370x335 mm
- QTY/CTN: 10 PCS
- MOQ: 10 PCS

UE-HS-E1026



- A large 9.0 liter (2.35 gallon) capacity pneumatic fluid extractor, can be used to extract many kinds of non-explosive liquids.
- Completely automatic using normal shop air.
- New safety design, when the tank is full of liquid, air inlet mechanism will be shut off automatically.
- One man, fast, clean and easy operating.
- None electric spark, safety for workshop.
- Max air consumption: 5.0 cfm.
- Description: Pneumatic fluid extractor (9 liters)
- Working psi: 70-170psi
- Pressure bar: (4.9-11.9)
- Capacity: 9.0 l
- Air inlet: 1/4"
- Tank Capacity: 2.0L
- Bottle Capacity: 1.0L
- N.W./G.W.: 1.3 kgs / 1.4 kgs
- Package Size: 300x150x250 mm
- QTY/CTN: 50 PCS
- MOQ: 50 PCS

UE-HS-E1025



- Brake fluid bleeder works with your air compressor to quickly assist in your brake bleeding!
- Flush and refill the entire brake system by yourself with this brake fluid bleeder.
- Comes with:
 - 34 oz Waster Brake Fluid Tank
 - 24 oz New Fluid tank that inserts into your master cylinder with 4 different provided adapters
 - Size(s) 25/32 in. to 1-7/32 in. diameter (21 To 30mm),
 - 31/32 in. to 1-1/4 in. diameter (24 To 32mm),
 - 1-3/32 in. to 1-15/32 in. (28 To 37mm),
 - 1-1/4 in. to 1-19/32 in. (32 To 41mm)
 - Air requirement: 90 to 120 PSI, Air inlet: 1/4" - 18 NP
 - Bleeds hydraulic brakes quick and effectively
 - N.W./G.W.: 1.6 kgs / 1.7 kgs
 - Package Size: 280x130x220mm
 - QTY/CTN: 50 PCS
 - MOQ: 50 PCS

UE-HS-E3243

Left-handed Brake Wind-back Tool



- Left-handed thrust bolt required for Ford, Citroen and Renault applications. Helps prevent damage to pistons and seals.
- Applications: Citroen, Ford, Renault
- N.W./ G.W.: 4.8 kgs / 5 kgs
- Package Size: 430x330x410 mm
- QTY/CTN: 10 PCS
- MOQ: 10 PCS

Automotive Repair Tools Set

UE-MT715012

12PCS 1/4" Dr.Socket Set

- N.W:0.45kgs
- G.W:0.65kgs
- Package Size:300x100x40mm
- Qty/CTN:200PCS



Contents

- 1PCS 1/4" Ratchet Wrench
- 1PCS 1/4" Extension Bar:3"
- 10PCS 1/4" Dr.Hexagon Socket:5,6,7,8,9,10,11,12,13,14mm

UE-HN715212

12PCS 1/2" Dr.Socket Set

- N.W:1.6kgs
- G.W:1.75kgs
- Package Size:355x105x50mm
- Qty/CTN:300PCS



Contents

- 1PCS 1/2" Ratchet Wrench
- 1PCS 1/2" Extension Bar:3"
- 10PCS 1/2" Dr.Hexagon Socket:5,6,7,8,9,10,11,12,13,14mm

UE-MT717324

24PCS 1/2" Dr.Socket Set



- N.W:20.6kgs
- G.W:21.6kgs
- Package Size:457x406x124mm
- Qty/CTN:4

Contents

- 18PCS 1/2" DR.HexagonZ Socket:10,11,12,13,14,15,16,17,18,19,20,21,22,23,24,27,30,32mm
- 1PCS 1/2" Universal Joint
- 2PCS 1/2" Extension Bar:5" 10"
- 1PCS 1/2" Speeder Handle:420mm
- 1PCS 1/2" Ratchet Wrench
- 1PCS 1/2" T handle Sliding Bar:10"

UE-MT715225

25PCS 3/8" Dr.Socket Set



- N.W:19.2kgs
- G.W:21.6kgs
- Package Size:392x184x180mm
- Qty/CTN:6

Contents

- 16PCS 3/8" DR. Socket:6,7,8,9,10,11,12,13,14,15,16,17,18,19,20,22mm
- 4PCS 3/8" Dr.Deep Socket:14,15,17,19mm
- 1PCS 3/8" Universal Joint
- 1PCS 3/8" Dr.Extension Bar:3"
- 1PCS 3/8" Dr.Extension Bar:10"
- 1PCS 3/8" 3 Way Adaptor
- 1PCS 3/8" Dr.Ratchet Handle

UE-MT715329

29PCS 1/2" Dr.Socket Set

- N.W:21kgs
- G.W:22kgs
- Package Size:362x215x225mm
- Qty/CTN:4

Contents

- 19PCS 1/2" DR. Socket:8,9,10,11,12,13,14,15,16,17,18,19,20,21,22,24,27,30,32mm
- 3PCS 1/2" Dr.Deep Socket:17,19,22mm
- 1PCS 1/2" Universal Joint
- 1PCS 1/2" Dr.Extension Bar:5"
- 1PCS 1/2" Dr.Extension Bar:10"
- 1PCS 1/2" 3 Way Adaptor
- 2PCS 1/2" Spark Plug Socket:16mm,21mm
- 1PCS 1/2" Dr.ratchet Handle



Automotive Repair Tools Set

UE-HN-86

Contents

14PCS 1/4" DR. Metric Socket: 3.5,4,4.5,5,5.5,6,7,8,9,10,11,12,13,14 mm
 8PCS 1/4" DR. Deep Socket: 6,7,8,9,10,11,12,13 mm
 2PCS 1/4" DR. Extension Bar: 2",4"
 1PC 1/4" DR. Universal Joint
 1PC 1/4" DR. Quick Ratchet Handle 72T
 1PC 1/4" Spinner Handle: 6"
 17PCS 1/4" Socket Bit: SL4,5,5,7 / PH1,2 / PZ1,2
 HEX3,4,5,6 / T8,T10,T15,T20,T25,T30
 1PC 1/4" DR. Sliding T-bar
 14PCS 1/2" DR. Metric Socket: 10,13,15,16,17,18,19,20,21,22,24,27,30,32 mm
 4PCS 1/2" DR. Deep Socket: 14,15,17,19 mm
 2PCS 1/2" DR. Extension Bar: 5",10"
 2PCS 1/2" DR. Spark Plug Socket: 16,21 mm
 1PC 1/2" DR. Universal Joint
 1PC 1/2" DR. Quick Ratchet Handle 72T
 1PC 1/2" DR. Bit Holder
 1PC 1/2" Multi Adapter 3/8"Fx1/2"M
 15PCS BITS(30L): SL8,SL10,SL12 / T40,T45,T50,T55 / PH3,PH4 / PZ3,PZ4,
 HEX8,HEX10,HEX12,HEX14

86PCS 1/4" & 1/2" DR. Socket Wrench Set

- N.W.: 5.5 kgs
- G.W.: 23 kgs / CTN
- Package Size:
390x320x30.5 mm
- QTY/CTN: 4 PCS



UE-MT715394

Contents

13PCS 1/4" Dr.Sockets:4,4.5,5.5,6,7,8,9,10,11,12,13,14mm
 8PCS 1/4" Dr.Deep Socket:6,7,8,9,10,11,12,13mm
 2PCS 1/4"Dr.Extension Bar:2" 4"
 1PCS 1/4"Dr.Flexible Extension Bar:6"
 1PCS 1/4"Dr.Universal Joint
 1PCS 1/4" Dr.Spinner Handle:
 1PCS 1/4" Dr.Sliding T Handle:115mm
 1PCS AD
 17PCS 1/4" Dr.inserted Reg Bit Sockets: He-3,4,5,6mm Reg-4,5,5,7mm Phillips-PH1, PH2
 Poze:PZ1,PZ2 Trox:T8,T10,T15,T20,T25,T30
 1PCS 1/4" Dr.Ratchet Handle
 18PCS 1/2" De.Hexagon Socket:10,11,12,13,14,15,16,17,18,19,20,21,22,23,24,27,30,32mm
 4PCS 1/2" Dr.Deep Socket:14,15,17,19mm
 2PCS 1/2 Extension Bar:5",10"
 2PCS 1/2" Spark Plug Socket:16mm;21mm
 1PCS 1/2" 3Way Adaptor
 1PCS 1/2" Universal Joint
 1PCS 5/16" X 1/2" Dr.Coupler
 3PCS Hex Key:1.5,2,2.5mm
 15PCS 5/16" Bit:Hex-8,10,12,14mm Reg:8,10,12mm Phillips:PH3,PH4 Pozi:PZ3 PZ4
 Trox:T40 T45 T50 T55
 1PCS 1/2" Ratchet Wrench

94PCS 1/4" & 1/2" Dr.Socket Set

- N.W:19.7 kgs
- G.W:20.7 kgs
- Package Size:
415x335x295 mm
- Qty/CTN:3 PCS



UE-MT716108

Contents

13PCS 1/4" Dr.Sockets:4,4.5,5.5,6,7,8,9,10,11,12,13,14mm
 8PCS 1/4" Dr.Deep Socket:6,7,8,9,10,11,12,13mm
 5PCS 1/4" E Type Dr.Sockets:E4,E5,E6,E7,E8
 1PCS 1/4"Dr.Universal Joint
 2PCS 1/4"Dr.Extension Bar:2" 4"
 1PCS 1/4" Dr.Sliding T Handle:115mm
 1PCS 1/4" Dr.Sliding Handle:6"
 18PCS 1/4" Inserted Reg Bit Sockets: Trox:T8 T10 T15 T20 T25 T27 T30 Hex:H3 H4 H5 H6
 Phillips:PH1 PH2 Pozi:PZ1 PZ2 Slotted:FD4 FD5.5 FD6.5
 1PCS 1/4" Dr.Ratchet Handle
 17PCS 1/2" De.Hex Socket:10,11,12,13,14,15,16,17,18,19,20,21,22,24,27,30,32mm
 5PCS 1/2" Dr.Deep Socket:14,15,17,19,22mm
 8PCS 1/2" E Type Dr.Socket:E10 E11 E12 E14 E16 E18 E20 E24
 1PCS 1/2" Dr.universal Joint
 2PCS 1/2" Spark Plug Socket:16mm 21mm
 2PCS 1/2" Extension Bar:5" 10"
 1PCS 1/2" 3Way Adaptor
 1PCS 5/16" X 1/2" Dr.Coupler
 17PCS 5/16" Bit: Hex:7,8,10,12,14mm Reg:8,10,12mm Phillips:PH3 PH4 Pozi:PZ3 PZ4
 Trox:T40 T45 T50 T55 T80
 1PCS 1/2" Dr Ratchet Handle
 3PCS Hex Key:1.5,2,2.5mm

108PCS 1/4" & 1/2" Dr.Socket Set

- N.W:21.5 kgs
- G.W:22.5 kgs
- Package Size:
415x335x295 mm
- Qty/CTN:3 PCS



WORK GLOVES



PU DIPPED



Description

13G White Nylon Gloves,
With White PU On Palm

Features

- Breathable open back
- Excellent grip and touch
- Polyester liner is also available

Application

- Electrical factory
- Precision assembling
- Semiconductor
- Gardening
- General material handling
- Assembling, inspecting and packing small or delicate parts



N.W.: 7.1 Kgs
G.W.: 7.6 Kgs
QTY/CTN: 240 Pairs
Package Size: 580x260x340 mm
MOQ: 3000 Pairs
QTY/20'CY: 126240 Pairs

UE-Y7001

PU DIPPED



Description

13G Grey Nylon Gloves,
With Grey PU On Palm

Features

- Breathable open back
- Excellent grip and touch
- Polyester liner is also available

Application

- Electrical factory
- Precision assembling
- Semiconductor
- Gardening
- General material handling
- Assembling, inspecting and packing small or delicate parts

N.W.: 7.1 Kgs
G.W.: 7.6 Kgs
QTY/CTN: 240 Pairs
Package Size: 580x260x360 mm
MOQ: 3000 Pairs
QTY/20'CY: 126240 Pairs



UE-Y7002

PU DIPPED



Description

13G Black Nylon Gloves,
With Black PU On Palm

Features

- Breathable open back
- Excellent grip and touch
- Polyester liner is also available

Application

- Electrical factory
- Precision assembling
- Semiconductor
- Gardening
- General material handling
- Assembling, inspecting and packing small or delicate parts



N.W.: 7.1 Kgs
G.W.: 7.6 Kgs
QTY/CTN: 240 Pairs
Package Size: 580x260x340 mm
MOQ: 3000 Pairs
QTY/20'CY: 126240 Pairs

UE-Y7003

LATEX DIPPED



Description

10G grey polyester gloves, with blue crinkle latex dipping on palm

Features

- Breathable open back
- Good grip and slip resistance for wrinkle palm
- Water proof on palm

Application

- General maintenance
- General material handling
- Assembly application when handling small to medium abrasive parts
- Forestry, logging and lumber operations
- Refuse collection
- Working with and managing cables
- Heavy-duty handling of castings, cores and fabricated metals
- Handling of fabricated

N.W.: 12 Kgs
G.W.: 12.5Kgs
QTY/CTN: 100 Pairs
Package Size: 580X280X280 mm
MOQ: 3000 Pairs
QTY/20'CY: 59300 Pairs



UE-Y7030

LATEX DIPPED



Description

13G hi-viz yellow polyester gloves, with black crinkle latex dipping on palm

Features

- Breathable open back
- Easy and comfortable grip
- Water proof on palm
- Nylon shell is also available

Application

- General maintenance
- General material handling
- Assembly application when handling small to medium abrasive parts
- Forestry, logging and lumber operations
- Refuse collection
- Working with and managing cables
- Gardening
- Construction



N.W.: 9.6 Kgs
G.W.: 10.1 Kgs
QTY/CTN: 144 Pairs
Package Size: 600X260X250 mm
MOQ: 3000 Pairs
QTY/20'CY: 99648 Pairs

UE-Y7031

Motorcycle Lift



UE-E01108
450 Kgs **CE**

Model: UE-E01108
Capacity: 450 kgs
Platform size: 680x360 mm
Min.Height: 110 mm
Max.Height: 400 mm
N.W.: 23 kgs
G.W.: 25 kgs
Package Size: 810x530x135 mm
QTY/20'CY: 450 PCS



Foot Pump

Motorcycle Support Stand



Rear Wheel
UE-F45502
200 Kgs



Model	Capacity (kgs)	N.W. (kgs)	G.W. (kgs)	Package Size (mm)	QTY/CTN (PCS)	QTY/20'CY (PCS)
UE-F45501	100	2.8	2.9	800x480x400	6	900
UE-F45502	200	4.85	4.9	880x570x430	6	780
UE-MT016	200	6	6.5	640x470x90	1	1200
UE-MT005	250	5	5.2	/	/	700
UE-MT014	200	4.8	5.2	640x380x90	1	1300



UE-T4001
106 Kgs

Aluminum

Model: UE-T4001
Capacity: 106 Kgs
Label Size: 255x255 mm
N.W.: 3 kgs
G.W.: 4 kgs
Package Size: 460x420x450 mm
QTY/20'CY: 300 PCS



UE-MT007
150 Kgs



Model: UE-MT007
Capacity: 150 kgs
N.W.: 9.5 kgs
G.W.: 10.2 kgs
Package Size: 620x440x90mm
QTY/20'CY: 1200 PCS

Motorcycle Stand

Model: UE-MT006
Capacity: 150 kgs
N.W.: 6.3 kgs
G.W.: 6.6 kgs
Package Size: 370x320x290 mm
QTY/20'CY: 540 PCS

UE-MT006
150 Kgs



Motorcycle Parking Stand



UE-MT028
300 Kgs



UE-MT060
300 Kgs

Model:	UE-MT028	UE-MT060
Capacity:	300 kgs	300 kgs
N.W.:	10.5 kgs	8.0
G.W.:	11.5 kgs	9.2
Package Size:	640x540x160 mm	560x530x125 mm
QTY/20'CY:	460 PCS	750 PCS
MOQ:	50 PCS	—

Motorcycle Lifting Jack



UE-E4101
450 Kgs

Model:	UE-E4101
Capacity:	450 kgs
Min.Height:	100 mm
Max.Height:	340 mm
N.W.:	15 kgs
G.W.:	16 kgs
Package Size:	530x180x170 mm
QTY/20'CY:	1250 PCS



UE-E3001
500 Kgs

Model:	UE-E3001
Capacity:	500 kgs
Min.Height:	90 mm
Max.Height:	405 mm
N.W.:	14 kgs
G.W.:	15 kgs
Package Size:	520x340x135 mm
QTY/20'CY:	1430 PCS

Motorcycle Dolly



UE-MT2211
600 Kgs

Model:	UE-E2211
Capacity:	600 kgs
Overall dimension:	2800x730x70 mm
Package Size:	1030x300x115 mm
N.W.:	47 kgs
G.W.:	49 kgs
QTY/20'CY:	430 PCS



UE-E04806
1500 Kgs

Model:	UE-E04806
Capacity:	1500 kgs
PRODUCT SIZE:	2500x900x260 mm
Package Size:	950x630x100 mm
N.W.:	42 kgs
G.W.:	43 kgs
QTY/20'CY:	460 PCS



Vacuum Brazed Diamond Tools

DESC. Vacuum Brazed Diamond Graver
ITEM NO. : AMG-MT013



Order number	Rear handle diameter (mm)	Grinding head shape (mm)	Grinding zone diameter (mm)
MT600606	6	cylinder	6
MT600605Z	6	Cone	5
MT600615Z	6	Cone	15
MT600622Z	6	Cone	22
MT600615	6	cylinder	15
MT600618	6	cylinder	18

Note: Various spec. and size .

DESC. :Vacuum Brazed Diamond Grinding Wheel
ITEM NO. : AMG-AL-012



Order number	diameter(mm)	thickness(mm)	Aperture(mm)	Range of grit
AL1502525	150	25	25	30/40
AL2502532	250	25	32	35/45
AL4005075	400	50	75	50/60
AL40040127	400	40	127	80/100
AL5005075	500	50	75	

Use: Mainly used for grinding and peeling of metal materials.

Note: Different shapes and sizes are available upon request.



DESC. :Vacuum Brazed Diamond AMG-AL012 Profile Wheel
ITEM NO. : AMG-GS



Order number	name	Outer diameter (mm)	Bore(mm)	Tax-included unit price(RMB)
AMG-GS400	Diamond high speed grinder	400	75	¥27800 (Grinding wheel)
AMG-GS500	Diamond high speed grinder	500	75	¥29800 (Grinding wheel)

Use: Mainly used for grinding and peeling in CNC centre.

Note: Different shapes and sizes are available upon request.

Vacuum Brazed Diamond Tools

DESC. : Advanced Vacuum Brazed Diamond Cup Wheel
Special complex material

ITEM NO. : AMG-AM01



Diameter/mm	Thickness/mm	Bore/mm	Range of Grit
80mm	1.5-3mm	16/20/22. 23	30/40 35/45 50/60 80/100 100/120
100mm		16/20/22. 23	
110mm		20/22. 23	
125mm		20/22. 23	
150mm		20/22. 23	
180mm		20/22. 23	
230mm		20/22. 23	

Use: Mainly used for grinding surface metal welding points.

Feature: With special technology of diamond brazing, the grinding effect will be much better and efficiency much higher. Using special complex material to reduce noising and insulate heat.

Note: Dia 80-230mm. Various spec. and thickness are available upon client' s reques.

DESC. : Vacuum Brazed Diamond Grinding & Cutting Disk
ITEM NO. : AMG-MC01



Diameter/mm	Thickness/mm	Bore/mm	Range of Grit
80mm	2mm	16/20/22. 23	30/40 35/45 50/60 80/100 100/120
100mm	3mm	16/20/22. 23	
110mm	3mm	20/22. 23	
125mm	3mm	20/22. 23	
150mm	3mm	20/22. 23	
180mm	3mm	20/22. 23	
230mm	3mm	20/22. 23	

Use: Mainly used for grinding and cutting the surface of Cast iron metal etc. materials.

Feature: With special technology of diamond brazing, the grinding effect will be much better and efficiency much higher.

Note: Dia 80-230mm. Various spec. and thickness are available upon client' s reques.

DESC. : Small Diamond Saw Blade
ITEM NO. : AMG-AC01



Diameter/mm	Thickness/mm	Bore/mm	Teeth
105	1.2	20/22. 23	12
110	1.2	20/22. 23	12
115	1.4	20/22. 23	13
125	1.4	20/22. 23	15
150	1.6	20/22. 23	11
180	1.6	20/22. 23	13
230	1.8	20/22. 23	16

USE: Specially used for cutting stainless steel, angle steel and other metal materials.

Feature: Cutting sharp, long service life, small gap and less scraps, low noise, cut surface is bright and clean, energy saving equipment.

Note: Various spec. and size available upon client' s request.

Spot welding machine series



UE-6G

Input voltage: 220V/380V 50/60Hz
Input power: 19KVA
Input current: 50A
Output voltage: 1-13V
Operation way: Electronic timer continuously
Welding time: 0-99s
package: 45x56x95cm
weight: 49kg



UE-6L

Input voltage: 220V/380V 50/60Hz
Input power: 19KVA
Input current: 50A
Output voltage: 1-13V
Operation way: Electronic timer continuously
Welding time: 0-99s
package: 60x45x98cm
weight: 73kg



UE-7G

Input voltage: 220V/380V 50/60Hz
Input power: 20KVA
Input current: 51A
Output voltage: 1-13V
Operation way: Electronic timer continuously
Welding time: 0-99s
package: 45x56x95cm
weight: 51kg



UE-7L

Input voltage: 220V/380V 50/60Hz
Input power: 20KVA
Input current: 51A
Output voltage: 1-13V
Operation way: Electronic timer continuously
Welding time: 0-99s
package: 60x45x98cm
weight: 81kg

Spot welding machine series



UE-8G

Input voltage: 220V/380V 50/60Hz
Input power: 21KVA
Input current: 55A
Output voltage: 1-13V
Operation way: Electronic timer continuously
Welding time: 0-99s
package: 45x56x95cm
weight: 53kg



UE-8L

Input voltage: 220V/380V 50/60Hz
Input power: 21KVA
Input current: 55A
Output voltage: 1-13V
Operation way: Electronic timer continuously
Welding time: 0-99s
package: 60x45x98cm
weight: 83kg



UE-9BX

Input voltage: 220V/380V 50/60Hz
Rated input power: 12.3KVA
Rated input current: 50A
Output voltage: 32A
Output voltage: 1-13V
Operation way: Electronic timer continuously
Welding time: 0-99s
package: 35x60x82cm
weight: 35kg



UE-9G

Input voltage: 220V/380V 50/60Hz
Input power: 22KVA
Input current: 57A
Output voltage: 1-13V
Operation way: Electronic timer continuously
Welding time: 0-99s
package: 45x56x95cm
weight: 55kg

Spot welding machine series



UE-10DC

Input voltage: AC 400V 50/60Hz
Input power: 38KVA
Input current: 16A
Output voltage: 1-15V
Operation way: Electronic timer continuously
Welding time: 0-700ms
package: 80x68x203cm
weight: 12kg



UE-10L

Input voltage: 220V/ 50/60Hz
Rated power: 1.5KVA
Fuse : 4-10A
Insulation grade: IP-23
Inverter: IGBT
Welding mode: Arc stud welding
package: 72x60x164cm
weight: 12/20kg



UE-14ACX

Input voltage: AC 380V 50/60Hz
Rated input power: 50KVA
Rated input current: 60A
Maximum voltage: 14000AA
Output voltage: 1-13V
Operation way: Electronic timer continuously
Welding time: 0-99s
package: 80x68x203cm
weight: 175kg



UE-16DC

Input voltage: AC 400V 50/60Hz
Input power: 30KVA
Input current: 32A
Output voltage: 1-15V
Operation way: Electronic timer continuously
Welding time: 0-700ms
package: 80x68x203cm
weight: 118kg

Spot welding machine series



UE-18DC

Input voltage: AC 400V 50/60Hz
Input power: 30KVA
Input current: 38A
Output voltage: 1-15V
Operation way: Electronic timer continuously
Welding time: 0-700ms
package: 80x68x203cm
weight: 128kg



UE-28DC

Input voltage: AC 400V 50/60Hz
Rated power: 30KVA
Rms: 38A
Insulation grade: IP-21
Welding time: 0-700ms
package: 80x68x203cm
weight: 130kg



UE-60L

Input voltage: 220V 50/60Hz
Rated power: 1.5KVA
Fuse: 4-10A
Insulation grade: H
Capacitance: 66000 UF
No-load voltage: 60-200V
package: 72x60x155cm
weight: 52kg



UE-65L

Input voltage: 220V/ 50/60Hz
Rated power: 3KVA
Fuse: 4A
Insulation grade: H
Capacitance: 66000 UF
Inverter: IGBT
No-load voltage: 50-150V
Welding mode: Dent pulling
package: 53x60x164cm
N/W: 12/20kg

Spot welding machine series



UE-65L-88A

Input voltage: 220V/ 380V 50/60Hz
Input power: 7KVA
Input current: 54A/18A
Output voltage: 1-13V
Operation way: Electronic timer continuously
Welding time: 0-99s
package: 55x65x82cm
N/W: 10.5kg/28kg



UE-80L

Input voltage: 220V 50/ 60Hz
Rated power: 2.0KVA
Fuse: 4-10A
Insulation grade: H
No-load voltage: 60- 240V
package: 72x60x155cm
weight: 60kg



UE-85A

Input voltage: 220V/380V 50/60Hz
Input power: 6.3KVA
Input current: 40A/12A
Output voltage: 1-13V
Operation way: Electronic timer continuously
Welding time: 0-99s
package: 55x65x110cm
weight: 28kg



UE-85DC

Input voltage: 220V/380V 50/60Hz
Rated power: 7KVA
Input current: 40A/12A
Output voltage: 1-13V
Operation way: Electronic timer continuously
Welding time: 0-99s
package: 45x56x95cm
weight: 48kg

Spot welding machine series



UE-86A

Input voltage: 220V/380V 50/60Hz
Input power: 6.5KVA
Input current: 42A/14A
Output voltage: 1-13V
Operation way: Electronic timer continuously
Welding time: 0-99s
package: 55x65x110cm
weight: 28kg



UE-86DC

Input voltage: 220V/380V 50/60Hz
Rated power: 7.3KVA
Input current: 42A/14A
Output voltage: 1-13V
Operation way: Electronic timer continuously
Welding time: 0-99s
package: 45x56x95cm
weight: 50kg



UE-87A

Input voltage: 220V/380V 50/60Hz
Input power: 6.7KVA
Input current: 48A/16A
Output voltage: 1-13V
Operation way: Electronic timer continuously
Welding time: 0-99s
package: 55x65x110cm
weight: 28kg



UE-87DC

Input voltage: 220V/380V 50/60Hz
Rated power: 7.5KVA
Input current: 48A/16A
Output voltage: 1-13V
Operation way: Electronic timer continuously
Welding time: 0-99s
package: 45x56x95cm
weight: 54kg

Spot welding machine series



UE-88A

Input voltage: 220V/380V 50/60Hz
Input power: 7KVA
Input current: 54A/18A
Output voltage: 1-13V
Operation way: Electronic timer continuously
Welding time: 0-99s
package: 55x65x82cm
weight: 28kg



UE-88DC

Input voltage: 220V/380V 50/60Hz
Rated power: 8KVA
Input current: 54A/18A
Output voltage: 1-13V
Operation way: Electronic timer continuously
Welding time: 0-99s
package: 45x56x95cm
weight: 58kg



UE-90G

Input voltage: 220V/380V 50/60Hz
Input power: 6.1KVA
Input current: 40A/12A
Output voltage: 1-13V
Operation way: Electronic timer continuously
Welding time: 0-99s
package: 55x65x82cm
weight: 28kg



UE-91G

Input voltage: 220V/380V 50/60Hz
Input power: 6.3KVA
Input current: 42A/14A
Output voltage: 1-13V
Operation way: Electronic timer continuously
Welding time: 0-99s
package: 55x65x82cm
weight: 28kg

Spot welding machine series



UE-92G

Input voltage: 220V/380V 50/60Hz
Input power: 6.5KVA
Input current: 48A/16A
Output voltage: 1-13V
Operation way: Electronic timer continuously
Welding time: 0-99s
package: 55x65x82cm
weight: 28kg



UE-93G

Input voltage: 220V/380V 50/60Hz
Input power: 6.8KVA
Input current: 54A/18A
Output voltage: 1-13V
Operation way: Electronic timer continuously
Welding time: 0-99s
package: 55x65x82cm
weight: 28kg



UE-200 L

Input voltage: 400V or 230V
Rated input power: 10.5KVA
Rated input current: 15A
No-load output voltage : 50V
Efficiency: $\geq 90\%$
Power factor: ≥ 0.95
Insulation grade: F
Frequency: 60-120KHz
Steel wire diameter: ϕ 0.6-1.2mm
Alu alloy wire diameter: ϕ 0.8-1.2mm
Copper alloy wire diameter: ϕ 0.6-1.4mm
Wire feeder: Four-roll drive
Package dimensions: 93x35x83cm
weight: 92kg



UE-230 L

Input voltage: 400V or 230V
Rated input power: 10.5KVA
Rated input current: 15A
No-load output voltage: 50V
Efficiency: $\geq 90\%$
Power factor: ≥ 0.95
Insulation grade: F
Frequency: 60-120KHz
Steel wire diameter: ϕ 0.6-1.2mm
Alu alloy wire diameter : ϕ 0.8-1.2mm
Copper alloy wire diameter: ϕ 0.6-1.4mm
Wire feeder: Four-roll drive
Package dimensions: 93x35x83cm
weight: 94kg

Spot welding machine series



UE-4250-2E

Input voltage: 380V 50/60Hz
No-load output voltage: 20-37V
Insulation grade: F
dimensions: 38x85x89cm
weight: 98kg



UE-4280-2E

Input voltage: 380V 50/60Hz
No-load output voltage: 20-38V
Insulation grade: F
dimensions: 38x85x89cm
weight: 100kg



UE-4500

Input voltage: 220V/380V 50/60Hz
Input power: 16KVA
Input current: 42A
Output voltage: 1-13V
Operation way: continuously
Welding time: 0-99s
package: 60x45x98cm
weight: 52kg



UE-5000

Input voltage: 220V/380V 50/60Hz
Input power: 18KVA
Input current: 47A
Output voltage: 1-13V
Operation way: continuously
Welding time: 0-99s
package: 60x45x98cm
weight: 54kg

Spot welding machine series



UE-5015L

include 1: IGBT inverter dent puller
include 2: IGBT inverter aluminium dent puller
include 3: Crossbar lifter with 2 or 4 kickstands



UE-5288-2E

Input voltage: 380V 50/60Hz
No-load output voltage: 20-40V
Insulation grade: F
dimensions: 38x85x89cm
weight: 105kg



UE-5500-2E

Input voltage: 380V 50/60Hz
No-load output voltage: 21-46V
Insulation grade: F
dimensions: 88x47x89cm
weight: 108kg



UE-6000

Input voltage: 220V/380V 50/60Hz
Input power: 19KVA
Input current: 50A
Output voltage: 1-13V
Operation way: continuously
Welding time: 0-99s
package: 60x45x98cm
weight: 56kg

Spot welding machine series



UE-6016

- include 1: Crossbar lifter with 2 or 4 kickstands
- include 2: Dent repair glue pulling kit
- include 3: IGBT inverter dent puller



UE-7000

- Input voltage: 220V/380V 50/60Hz
- Input power: 20KVA
- Input current: 51A
- Output voltage: 1-13V
- Operation way: continuously
- Welding time: 0-99s
- package: 60x45x98cm
- weight: 58kg



UE-8000

- Input voltage: 220V/380V 50/60Hz
- Input power: 21KVA
- Input current: 55A
- Output voltage: 1-13V
- Operation way: continuously
- Welding time: 0-99s
- package: 60x45x98cm
- weight: 60kg



UE-8000-250

- Input voltage: 220V/380V 50/60Hz
- Input power: 21KVA
- Input current: 55A
- Output voltage: 1-13V
- Operation way: continuously
- Welding time: 0-99s
- package: 87x46x165cm
- weight: 138kg

Spot welding machine series



UE-9000

Input voltage: 380V 50/60Hz
Input power: 22KVA
Input current: 57A
Output voltage: 1-13V
Operation way: continuously
Welding time: 0-99s
package: 72x60x155cm
weight: 86kg



UE-9000A

Input voltage: 220V/380V 50/60Hz
Input power: 22KVA
Input current: 57A
Output voltage: 1-13V
Operation way: Electronic timer continuously
Welding time: 0-99s
package: 72x60x155cm
weight: 86kg



UE-9008

include 1: PDR single layer brace long rods
include 2: PDR double layer brace short rods
include 3: Dent repair glue pulling kit



UE-9015

1. The tools are manufactured of special steel which has better creep strength and rupture strength than traditional steel.
2. State-of-the-art designed tools with different lengths, diameters, handles and points to meet the requirements of different kinds of sheet metals.
3. With luxury trolley, practical and convenient.
4. With hammers specifically for aluminium car bodies.

Spot welding machine series



UE-9028

- include 1: IGBT inverter aluminium dent puller
- include 2: Crossbar lifter with 2 or 4 kickstands
- include 3: Dent repair glue pulling kit



UE-9038

- include 1: IGBT inverter aluminium dent puller
- include 2: Crossbar lifter with 2 or 4 kickstands
- include 3: Dent repair glue pulling kit



UE-9060

- include 1: Tools for Collision Repair(optional)
- include 2: Tools for Riveting(optional)
- include 3: Dent repair glue pulling kit



UE-9080

- include 1: AIR TOOLS
- include 2: TOOL SETS
- include 3: MEASURING TOOLS
- include 4: PULLERS
- include 5: PLIERS
- include 6: PROTECTIVE ARTICLES
- include 7: CONSUMABLES

Spot welding machine series



UE-9900X

Input voltage: 380V 50/60Hz
Input power: 30KVA
Input current: 60A
Output voltage: 1-13V
Operation way: continuously
Welding time: 0-99s
package: 70x53x180cm
weight: 138kg



UE-13000

Input voltage: 380V 50/60Hz
Input power: 45KVA
Input current: 60A
Output voltage: 1-13V
Operation way: continuously
Welding time: 0-99s
package: 74x61x180cm
weight: 168kg



UE-15000

Input voltage: 380V 50/60Hz
Input power: 60KVA
Input current: 80A
Output voltage: 1-13V
Operation way: continuously
Welding time: 0-99s
package: 80x68x203cm
weight: 195kg



UEMIG180

Input voltage: 220V
Rated input power: 5KVA
Rated input current: 8.3A
No-load output voltage: 50V
Efficiency: $\geq 90\%$
Power factor: ≥ 0.95
Insulation grade: F
Frequency: 60-120KHz
Steel wire diameter: ϕ 0.6-0.8mm
Wire feeder: Two-roll drive
dimensions Main machine : 43x28x32cm
weight: 13kg

Spot welding machine series



UEMIG200L-2

Input voltage: 400V or 230V
Rated input power: 10.5KVA
Rated input current: 15A
No-load output voltage: 50V
Efficiency: $\geq 90\%$
Power factor: ≥ 0.95
Insulation grade: F
Frequency: 60-120KHz
Steel wire diameter: ϕ 0.6-1.2mm
Alu alloy wire diameter : ϕ 0.8-1.2mm
Copper alloy wire diameter: ϕ 0.6-1.4mm
Wire feeder: Four-roll drive
Package dimensions: 94x51x117cm
weight: 98kg



UEMIG200L-3

Input voltage: 400V or 230V
Rated input power: 10.5KVA
Rated input current: 15A
No-load output voltage: 50V
Efficiency: $\geq 90\%$
Power factor: ≥ 0.95
Insulation grade: F
Frequency: 60-120KHz
Steel wire diameter: ϕ 0.6-1.2mm
Alu alloy wire diameter : ϕ 0.8-1.2mm
Copper alloy wire diameter: ϕ 0.6-1.4mm
Wire feeder: Four-roll drive
Package dimensions: 94x51x117cm
weight: 102kg



UEMIG250

Input voltage : 400V or 230V
Rated input power: 8KVA
Rated input current: 12A
No-load output voltage: 50V
Efficiency: $\geq 90\%$
Power factor: ≥ 0.95
Insulation grade: F
Frequency: 60-120KHz
Steel wire diameter: ϕ 0.6-1.2mm
Alu alloy wire diameter : ϕ 0.8-1.2mm
Copper alloy wire diameter: ϕ 0.6-1.2mm
Wire feeder: Four-roll drive
Package dimensions: 93x35x83cm
weight : 88kg



UEMIG300

Input voltage: 400V or 230V
Rated input power: 10KVA
Rated input current: 15A
No-load output voltage: 50V
Efficiency: $\geq 90\%$
Power factor: ≥ 0.95
Insulation grade: F
Frequency : 60-120KHz
Steel wire diameter: ϕ 0.6-1.2mm
Alu alloy wire diameter: ϕ 0.8-1.2mm
Copper alloy wire diameter: ϕ 0.6-1.4mm
Wire feeder: Four-roll drive
Package dimensions: 93x35x83cm
weight : 90kg

Spot welding machine series



UEMIG320

Input voltage: 400V or 230V
Rated input power: 11KVA
Rated input current: 17A
No-load output voltage: 55V
Efficiency: $\geq 90\%$
Power factor: ≥ 0.95
Insulation grade: F
Frequency: 60-120KHz
Steel wire diameter: ϕ 0.6-1.2mm
Alu alloy wire diameter: ϕ 0.8-1.2mm
Copper alloy wire diameter: ϕ 0.6-1.6mm
Wire feeder: Four-roll drive
Package dimensions: 93x35x83cm
weight: 92kg



UEMIG5215X

Input voltage: 220V
Rated input power: 5.3KVA
Rated input current: 8.5A
No-load output voltage: 50V
Efficiency: $\geq 90\%$
Power factor: ≥ 0.95
Insulation grade: F
Frequency: 60-120KHz
Steel wire diameter: ϕ 0.6-1.2mm
Wire feeder: Two-roll drive
Package dimensions: 93x35x83cm
weight: 88kg



UEMIG5260

Input voltage: 400V or 230V
Rated input power: 8KVA
Rated input current: 12A
No-load output voltage: 50V
Efficiency: $\geq 90\%$
Power factor: ≥ 0.95
Insulation grade: F
Frequency: 60-120KHz
Steel wire diameter: ϕ 0.6-1.2mm
Alu alloy wire diameter: ϕ 0.8-1.2mm
Copper alloy wire diameter: ϕ 0.6-1.2mm
Wire feeder: Four-roll drive
Package dimensions: 93x35x83cm
weight: 88kg



UEMIG5260X

Input voltage: 400V or 230V
Rated input power: 8KVA
Rated input current: 12A
No-load output voltage: 50V
Efficiency: $\geq 90\%$
Power factor: ≥ 0.95
Insulation grade: F
Frequency: 60-120KHz
Steel wire diameter: ϕ 0.6-1.2mm
Wire feeder: Two-roll drive
Package dimensions: 93x35x83cm
weight: 86kg

Spot welding machine series



UEMIG5300

Input voltage: 400V or 230V
Rated input power: 10KVA
Rated input current: 15A
No-load output voltage: 50V
Efficiency: $\geq 90\%$
Power factor: ≥ 0.95
Insulation grade: F
Frequency: 60-120KHz
Steel wire diameter: ϕ 0.6-1.2mm
Alu alloy wire diameter: ϕ 0.8-1.2mm
Copper alloy wire diameter: ϕ 0.6-1.4mm
Wire feeder: Four-roll drive
Package dimensions: 93x35x83cm
weight: 90kg



UEMIG5300X

Input voltage: 400V or 230V
Rated input power: 10KVA
Rated input current: 15A
No-load output voltage: 50V
Efficiency: $\geq 90\%$
Power factor: ≥ 0.95
Insulation grade: F
Frequency: 60-120KHz
Steel wire diameter: ϕ 0.6-1.2mm
Wire feeder: Two-roll drive
Package dimensions: 93x35x83cm
weight: 88kg



UEMIG5320

Input voltage: 400V or 230V
Rated input power: 11KVA
Rated input current: 17A
No-load output voltage: 55V
Efficiency: $\geq 90\%$
Power factor: ≥ 0.95
Insulation grade: F
Frequency: 60-120KHz
Steel wire diameter: ϕ 0.6-1.2mm
Alu alloy wire diameter: ϕ 0.8-1.2mm
Copper alloy wire diameter: ϕ 0.6-1.6mm
Wire feeder: Four-roll drive
Package dimensions: 93x35x83cm
weight: 92kg



UEMIG5320X

Input voltage: 400V or 230V
Rated input power: 11KVA
Rated input current: 17A
No-load output voltage: 55V
Efficiency: $\geq 90\%$
Power factor: ≥ 0.95
Insulation grade: F
Frequency: 60-120KHz
Steel wire diameter: ϕ 0.6-1.2mm
Wire feeder: Two-roll drive
Package dimensions: 93x35x83cm
weight: 90kg

Spot welding machine series



UE-2012S

Input voltage: AC230V 50/60Hz
Input current: 1.5A
Output voltage: 2.6V
Output current: 5-30A
Dimensions: 250x180x135mm
weight: 4.8kg



UE-80N

Input voltage: AC220V/380V
Frequency: 50/60HZ
Rated power: 2.2KVA
Output current: 3800A
Output voltage: 6-8V
Welding mode induction: welding
Number of welding guns: single gun
Packing size: 57*46*62cm
Weight: 45KG



UE-TIG200SII

Input voltage: 220V 50/60Hz
Rate input power : 29A
No-load voltage: 54V
Output current range: 12-180A
Rated output voltage: 17.2V
Overall dimension: 410x165x250mm
Weight: 7.5kg

Plasma cutting machine



UE-CUT40II

Input voltage: 220V 50/60Hz
Rate input power : 30A
No-load voltage: 230V
Output current range: 15-40A
Rated output voltage: 94V
Overall dimension: 410x165x260mm
Weight: 8kg

Wall-mounted vacuum cleaner



UE-FO-36L

Control method: On / off
 Colour: Yellow, gray
 Rated frequency: 50-60HZ
 Rated power: 1500W
 Hose length: 9M
 Vacuuming capacity: 36L
 Environment type: Wet and dry
 Net weight / gross weight: 29.7/30.5kg
 Package dimensions: 37*27*61cm



UE-FO-36-Z

Control method: Handle with controller
 Colour: Black + grey
 Rated frequency: 50-60HZ
 Rated power: 1500W
 Hose length: 9M
 Vacuuming capacity: 36L
 Environment type: Wet and dry
 Net weight / gross weight: 10/12kg
 Package dimensions: 76*27*35cm

Vacuum Drum



UE-6013X-A

Control method: Without controller / with controller
 Specification: $\phi 40\text{mm}$
 Tube quality: black, grey
 Input tube: 1.0m(L)
 Output tube: 10m (L)
 Number of packing boxes: 1 / carton

High voltage cantilever



UE-6011

Working pressure: 0.5-10Mpa
 Rotation angle: 360°
 medium: water
 Rotary head diameter: 8.5cm
 Material: Stainless steel 304
 Net weight / gross weight: 11.9/13.5kg
 Package dimensions: 143*20.7*23.7cm

Rotary spray



UE-6012X

Working pressure: 20kg

Rotation angle: 360 °

Flow: 2 tons / H

Power: 3W

Head: 200m

Water column spray height 4M

Supporting pump flow: 35L / min

Nozzle: two nozzles

Material: stainless steel 304

Net weight / gross weight: 4.5 / 5.1kg

Packing size: 73 * 22 * 13cm

Storm fan



UE-FO-1500

Voltage frequency: 220V / 50HZ

Power: 1500W

Speed: 35000r / min

Pressure: 70bar

Spraying amount: 0-1.5L / min

Packing quantity: 6 sets / carton

Packing size: 82 * 60 * 66cm

Automatic Proportioner 2018



UE-FO-2018

Proportion of professional vehicle cleaning wax

Design ratio: 0.2% -2%

Water source pressure: 0.6-8 kg

Standard flow: 30-2500L / hour

Takeover caliber: 3/4 inch

Automatic Proportioning Machine 2017



UE-FO-2017

Proportion of professional vehicle cleaning wax
Design ratio: 0.4-4%
Water source pressure: 0.6-8 kg
Standard flow: 30-2500L / hour
Takeover caliber: 3/4 inch

Steam sauna machine



UE-FO-180

Power: 2000W
Rated voltage: 220V
Rated frequency: 50HZ
Steam pressure: 4.5BAR
Steam flow: 28G / MIN
Temperature: 130 degrees Celsius
Pot capacity: 1.8L
Carton size: 45X30X31cm
Packing quantity: 1 set / box, 2 sets / piece

Mini ozone machine



UE-FO-12

Power: 50W
Air output: 25L
Working voltage: 12V
Function: Vehicle-mounted digital display
Features: efficient and thorough disinfection,
environmental protection
Carton size: 23X18X16cm / 1pcs

Digital display sterilizer



UE-FO-600

Power: 100W
Working voltage: 220V / 50HZ
Gas volume: 80L / H
Process: Ozone generator
Applicable temperature: -20 °C -70 °C
Amount of ozone: 4000mg / h / m²
Accessories: electronic display, PC tube
Configuration: One air tube
Net weight / Gross weight: 12 / 13KGS
Package size: 33X22X60cm

Honeycomb towel cabinet



UE-PP

Material: PP plastic
Packing quantity: 50 pcs/carton
Packing method: carton
Color: pink, blue, yellow, green
Combination method: free combination

Free combination towel rack



UE-FO-5

material: plastic
Number of layers: single row five layers
Combination method: free combination
Packing quantity: 4 sets/carton
Packing method: carton packing

Polishing machine hanger



UE-FO-53

Material: Imported engineering ABS plastic
Net weight/Gross weight: 1.9/2.3kg
Carton size: 8pcs/carton

Polishing machine hanger



UE-FO-37

Material: Imported engineering ABS plastic
Net weight/Gross weight: 1.9/2.3kg
Carton size: 10pcs/carton

Five-position wax box rack



UE-FO-27

Material: Imported engineering ABS plastic
Packing quantity: 20 pcs/carton

Plastic tool hanging board

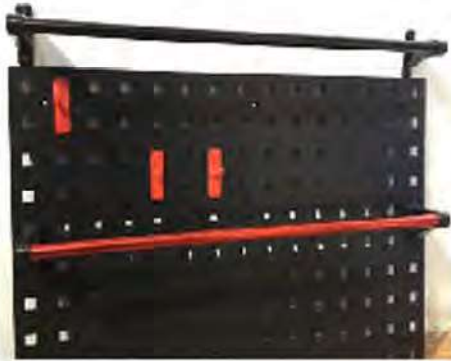

UE-FO-22

Material: Imported engineering ABS plastic
Size: 40*60*0.8cm
Wall hanging rod: 16/set
Card board hanging rod: 16/set
Packing quantity: 23 pieces/carton

3cm thickness floor grill

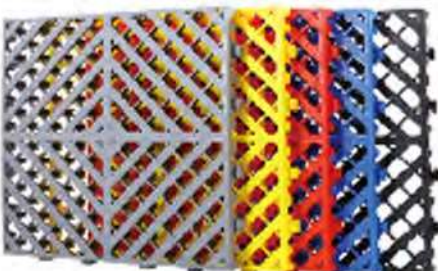

UE-FO-3CM

Material: PP plastic
Packing quantity: 24 pieces/carton
Packing method: carton
Color: gray, yellow, black, red, green, blue
Combination method: free splicing
Size: 40*40*3cm

5cm thickness floor grill

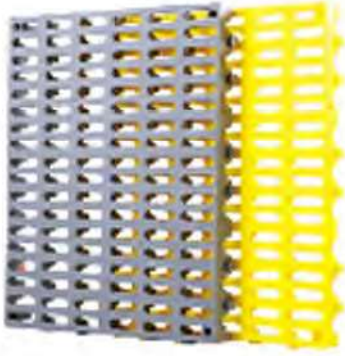

UE-FO-5CM

Material: PP plastic
Packing quantity: 15 pieces/carton
Packing method: carton
Color: gray, yellow, black, red, green, blue
Combination method: free splicing
Size: 40*60*5cm

4cm thickness floor grill

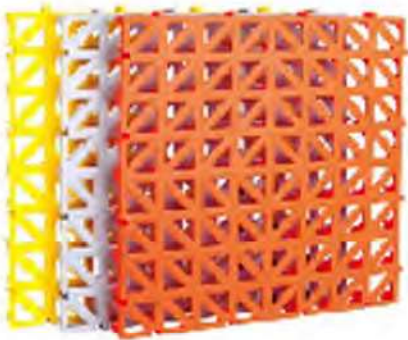

UE-FO-4CM

Material: PP plastic
Packing quantity: 24 pieces/carton
Packing method: carton
Color: gray, yellow, black, red, green, blue
Combination method: free splicing
Size: 50*50*4cm

1.8cm thickness floor grille

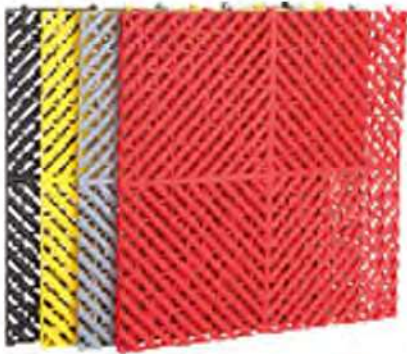

UE-FO-1.8CM

Material: PP plastic
Packing quantity: 40 pieces/carton
Packing method: carton
Color: gray, yellow, black, red, green, blue
Combination method: free splicing
Size: 50*50*1.8cm

Filter constant water tank



UE-FO-99

Material: PP plastic
Packing quantity: 12 pcs/carton
Packing method: carton
Color: blue/gray

Iron foam machine



FO-909A

Barrel thickness: 1.2mm (12kg)
Bucket thickness: 1.5mm (14kg)
Working pressure: 1-3bar
Capacity: 80L
Maximum pressure of safety valve: 3bar
Tube length: 5 meters
Packing size: 43X39X80cm

Stainless steel foam machine



FO-909B

Barrel thickness: 1.2mm (12kg)
Bucket thickness: 1.5mm (14kg)
Working pressure: 1-3bar
Capacity: 80L
Maximum pressure of safety valve: 3bar
Tube length: 5 meters
Packing size: 40X40X82cm

Environmental protection plastic foam machine



FO-909S

Working pressure: 1-3bar
Capacity: 80L
Maximum pressure of safety valve: 3bar
Tube length: 7 meters
Bucket thickness: 11mm (13kg)
Accessories: standard
Packing size: 42X41X82cm

Dehydrator



FO-918B

Base: B cast iron / A steel plate
Voltage: 220V/380V
Power: 0.75kw/1.5kw
Material: All copper core motor, stainless steel barrel
Load: 13KG
Speed: 1400 r/min
Packing: wooden box packing
Packing size: 80X60X80cm
Net weight/Gross weight: 65/70KG

Single use wax water tank



FO-20L

Working pressure: 0.2-0.4Kpa
Capacity: 20L
Maximum pressure of safety valve: 3bar
Tube length: 8 meters
Barrel thickness: 2.0mm (13kg)
Accessories: standard
Packing size: 60*28.5*28.5cm

Eccentric vibration polishing machine series



FO-5818

Sand disc size: 125-150mm
Rated voltage: 120V/220V
Rated frequency: 50HZ/60HZ
Rated power: 1150W
No-load speed: 2000-4500r/min
Eccentric distance: 21mm
Net weight/Gross weight: 3.64/3.14kg
Carton size: 52*41*45cm/6pcs



FO-8851

Disc size: 160mm
Rated voltage: 120V/220V
Rated frequency: 50HZ/60HZ
Rated power: 1200W
No-load speed: 3200-9600r/min
Eccentric distance: 8mm
Net weight/Gross weight: 3.5/3.96kg
Carton size: 53.5*50*30cm/6pcs



FO-8815

Disc size: 123mm
Rated voltage: 120V/220V
Rated frequency: 50HZ/60HZ
Rated power: 1200W
No-load speed: 2000-4800r/min
Eccentric distance: 15mm
Net weight/Gross weight: 3.3/3.9kg
Carton size: 53.5*50*30cm/6pcs

Eccentric vibration polishing machine series



FO-103

Disc size: 100mm
Rated voltage: 120V/220V
Rated frequency: 50HZ/60HZ
Rated power: 780W
No-load speed: 2000-5500r/min
Eccentric distance: 8mm
Net weight/Gross weight: 2.2/3.1kg
Carton size: 44*39*30cm/6pcs

Vertical polishing machine series



FO-2200

Disc size: 180mm
Rated voltage: 220-240V
Rated frequency: 50HZ/60HZ
Rated power: 1010W
No-load speed: 600-2200r/min
Net weight/Gross weight: 1.8/2.0kg
Carton size: 59*36*37.5cm/6pcs
Whether to match the plate: not equipped with sticky plate, sponge plate



FO-5186

Sand disc size: 180mm (7")
Rated voltage: 220-240V
Rated frequency: 50HZ/60HZ
Rated power: 900W
No-load speed: 600-4500r/min
Net weight/Gross weight: 1.9/2.1kg
Carton size: 44.5*30.5*50cm/8pcs
Whether to match the plate: with sticky plate, with wool plate



FO-3125A

Sand disc size: 125mm (5")
Rated voltage: 220-240V
Rated frequency: 50HZ/60HZ
Rated power: 420W
No-load speed: 0~3300r/min
Net weight/Gross weight: 1.4/1.6kg
Carton size: 47*41*45cm/8pcs
Whether to match the plate: with sticky plate

Vertical polishing machine series



FO-3126

Sand disc size: 125mm (5")
Rated voltage: 220-240V
Rated frequency: 50HZ/60HZ
Rated power: 420W
No-load speed: 0~4400r/min
Net weight/Gross weight: 2.0/2.1kg
Carton size: 47*41*45cm/8pcs
Whether to match the plate: with sticky plate

Horizontal polishing machine series



FO-6818

Sand disc size: 125-150mm
Rated voltage: 120V/230V
Rated frequency: 50HZ/60HZ
Rated power: 1150W
No-load speed: 1000~3500r/min
Net weight/Gross weight: 2.4/2.68kg
Carton size: 52*41*45cm/6pcs
Spindle thread: M14



FO-822D

Disc size: 180mm
Rated voltage: 220-240V
Rated frequency: 50HZ/60HZ
Rated power: 1400W
No-load speed: 0~3000r/min
Net weight/Gross weight: 2.9/3.15kg
Carton size: 47*41*45cm/6pcs
Color: black, red
Whether to match the plate: with sticky plate, wool plate



9618

Sand disc size: 180mm (7")
Rated voltage: 220-240V
Rated frequency: 50HZ
Rated power: 1400W
No-load speed: 800-3500r/min
Net weight/Gross weight: 2.5/2.78kg
Carton size: 47*41*45cm/6pcs

Horizontal polishing machine series



FO-806

Polishing diameter: 1 1/2"/3"
Rated voltage: 220-240V
Rated frequency: 50HZ
Rated power: 600W
No-load speed: 900-4400r/min
Net weight/Gross weight: 1.9/2.4kg
Packing quantity: 8pcs

Pneumatic polishing machine series



FO-5000A

Sand disc size: 125mm (5")
Free speed: 10000rpm
Deflection diameter: 5mm
Weight: 0.9kg
Air consumption: 340L/min
Operating air pressure: 6.2kgf/cm²
Air inlet pressure: 1/4
Carton size: 12pcs/piece



FO-5000B

Sand disc size: 125mm (4 1/5")
Free speed: 10000rpm
Deflection diameter: 5mm
Weight: 0.9kg
Air consumption: 340L/min
Operating air pressure: 6.2kgf/cm²
Air inlet pressure: 1/4
Carton size: 12pcs/piece



FO-14802

Sand disc size: 5"
Free speed: 10000rpm
Applicable air pressure: 6.2kgf/cm²
Weight: 0.9kg
Trachea: 6*10
Deflection diameter: 5mm
Air consumption: 0.34m³/min
Air inlet: 1/4"
Hose size: 3/8"

Pneumatic polishing machine series

FO-13801



Sand disc size: 4"/5"
Free speed: 10000rpm
Deflection diameter: 5mm
Air consumption: 0.34m³/min
Air inlet: 1/4"
Operating air pressure: 6.2kgf/cm²
Packing quantity: 12pcs/carton

FO-55802



Disc size: 2"/3"
Free speed: 18000rpm
Applicable air pressure: 6-8kgf/cm²
Weight: 0.9kg
Trachea: 6*10
Appearance size: 150mm

FO-55801



Disc size: 2"/3"
Free speed: 18000rpm
Applicable air pressure: 6-8kgf/cm²
Weight: 0.9kg
Trachea: 6*10
Appearance size: 150mm

Disc grinder



UE-2015

Bracket height:880-1200mm
Decelerate motor voltage : 220/110V 50/60HZ
Decelerate motor power:400W/700W(option)
Circumrotate rate:120rpm
Working temperature: -20℃ to 40℃
Maximum diameter of brake disc:500mm
Maximum thickness of brake disc:42mm
Cutting accuracy of brake disc:≤0.02mm
Weight: 120KG

Reel series



FO-6000 water drum

Pipe quality: PVC yarn
Specification: $\Phi 8 \times 12 \text{mm}$
Input tube: 1.0m(L)
Output tube: 10m(L)
Working pressure: 6bar
Bursting pressure: 24bar
Gross weight/net weight: 4.5/4.2kg
Number of packing boxes: 6 pcs/carton



FO-6000 air drum

Tube quality: PU yarn clamp
Specification: $6.5 \times 10 \text{mm}$
Input tube: 1.0m(L)
Output tube: 10m(L)
Working pressure: 6bar
Bursting pressure: 24bar
Gross weight/net weight: 4.5/4.2kg
Number of packing boxes: 6 pcs/carton



FO-6000 electric drum

Rated power: AC220V-240V
Specification: $2 \times 1.5 \text{m}^2$
Input line: 1.0m(L)
Output line: 10m
Gross weight/net weight: 4.5/4.2kg
Number of packing boxes: 6 pcs/carton
Packing method: neutral packing
color: gray



FO-6001A water drum

Bracket height: 880-1200mm
Decelerate motor voltage : 220/110V 50/60HZ
Decelerate motor power: 400W/700W(option)
Circumrotate rate: 120rpm
Working temperature: -20°C to 40°C
Maximum diameter of brake disc: 500mm
Maximum thickness of brake disc: 42mm
Cutting accuracy of brake disc: $\leq 0.02 \text{mm}$
Weight: 120KG

Reel series



FO-6001A air drum

Tube quality: PU yarn clamp
Specification: 6.5*10mm
Input tube: 1.0m(L)
Output tube: 10m (L)
Working pressure: 6bar
Bursting pressure: 24bar
Gross weight/net weight: 4.5/4.2kg
Number of packing boxes: 6 pcs/carton



FO-6001A electric drum

Rated power: AC220V-240V
Specification: 2*1.5m²
Input line: 1.0m(L)
Output line: 10m
Gross weight/net weight: 4.5/4.2kg
Number of packing boxes: 6 pcs/carton
Packing method: neutral packing
color: gray

Combination cabinet series



FO-6010A

Built-in material: steel
External material: plastic
Any combination: three in one/four in one...



FO-6010H

Built-in material: steel
External material: plastic
Any combination: three in one/four in one...

High pressure drum series



FO-6008A(High pressure drum)

Tube quality: high pressure braided hose
Specification: G3/8"
Input tube: 1.0m(L)
Output tube: 15m(L)
Working pressure: 150-180kg
Burst pressure: 180kg
Gross weight/net weight: 18/19.2kg
Carton size: 51*17*52.5cm/1pcs



FO-6008B (high pressure drum)

Tube quality: high pressure braided hose
Specification: G3/8"
Input tube: 1.0m(L)
Output tube: 10m(L)
Working pressure: 150-180kg
Bursting pressure: 220kg
Net weight/Gross weight: 17.8/19.2kg
Carton size: 51*17*52.5cm/1pcs



FO-6060A (water and air drum)

Tube quality: water PVC yarn clamp, air PU yarn clamp
Specification: $\Phi 8*12/6.5*10$ mm
Input line: double 1.0m(L)
Output line: double 10m
Gross weight/net weight: 6.75/6.5kg
Number of packing boxes: 6 pcs/carton
Packing method: neutral packing
color: White



FO-6060B (water and air drum)

Tube quality: water PVC yarn clamp, air PU yarn clamp
Specification: $\Phi 8*12/6.5*10$ mm
Input line: double 1.0m(L)
Output line: double 10m
Gross weight/net weight: 6.75/6.5kg
Number of packing boxes: 6 pcs/carton
Packing method: neutral packing
color: White

The Smurfs Series



Foam gun **UE-FO-127**

Working pressure: 6-9.2KG
Capacity: 1000ML
Solution: neutral (special solution)
Process: oxidation, anti-corrosion treatment
Material: aluminum, plastic
Adaptation temperature: 1-50°
Packing quantity: 12 pcs/carton

UE-FO-137

Big foam gun



Working pressure: 6-9.2KG
Capacity: 1000ML
Solution: neutral (special solution)
Process: oxidation, anti-corrosion treatment
Material: aluminum, plastic
Adaptation temperature: 1-50°
Packing quantity: 12 pcs/carton

UE-FO-127-2

Interior cleaning gun



Working pressure: 6-9.2KG
Capacity: 1000ML
Solution: neutral (special solution)
Process: oxidation, anti-corrosion treatment
Material: aluminum, plastic
Adaptation temperature: 1-50°
Packing quantity: 12 pcs/carton

UE-FO-127-3

Needle gun



Working pressure: 6-9.2KG
Capacity: 1000ML
Solution: neutral (special solution)
Process: oxidation, anti-corrosion treatment
Material: aluminum, plastic
Adaptation temperature: 1-50°
Packing quantity: 12 pcs/carton

The Smurfs Series



Ceiling gun UE-FO-127-4

Working pressure: 6-9.2KG
Capacity: 1000ML
Solution: neutral (special solution)
Process: oxidation, anti-corrosion treatment
Material: aluminum, plastic
Adaptation temperature: 1-50°
Packing quantity: 12 pcs/carton



UE-FO-137

Universal cleaning gun

Working pressure: 6-9.2KG
Capacity: 1000ML
Solution: neutral (special solution)
Process: oxidation, anti-corrosion treatment
Material: aluminum, plastic
Adaptation temperature: 1-50°
Packing quantity: 12 pcs/carton



UE-FO-95

Water blowing dust gun

Working pressure: 6-9.2KG
Material: aluminum, plastic
Process: oxidation, anti-corrosion treatment
Solution: neutral (special solution)
Adaptation temperature: 1-50°
Packing quantity: 30 pcs/carton



UE-FO-58

Imported high-efficiency foam pot gun

Function: Professional vehicle cleaning foam ratio
Pot capacity: 1L
Pot height: 26.5cm
Pot foam head size: 18cm
Diameter of the bottom of the pot: 8.2cm

The Smurfs Series



Efficient foam pot gun **UE-FO-37**

Function: Professional vehicle cleaning foam ratio
Pot capacity: 1L
Pot height: 26.5cm
Pot foam head size: 18cm
Diameter of the bottom of the pot: 8.2cm



UE-FO-90

High voltage quick connect gun

Configuration: Copper block connector
Spray angle: 0°/15°/25°/40°

Water and air cleaning gun series



UE-FO-212

Water blowing dust gun

Working pressure: 6-8KG
Process: oxidation, anti-corrosion treatment
Material: Aluminum
Solution: neutral (special solution)
Adaptation temperature: 1-50°
Packing quantity: 20 pcs/carton

UE-FO-196

Water vapor cleaning gun



Working pressure: 6-8KG
Process: oxidation, anti-corrosion treatment
Material: aluminum, plastic
Solution: neutral (special solution)
Adaptation temperature: 1-50°
Packing quantity: 20 pcs/carton

Water and air cleaning gun series

UE-FO-196

Water vapor mixing cleaning gun



Working pressure: 5-8KG
Tube quality: water PVC yarn clamp, air PU yarn clamp
Specification: Water pipe $\Phi 8 \times 12\text{mm}$
Specifications: Trachea $\Phi 6.5 \times 10\text{mm}$
Adjustable: adjustable water/fog
Gross weight/net weight: 0.75/0.65kg
Number of packing boxes: 20 pieces/carton

Black King Kong Series

Foam gun

UE-FO-147



Working pressure: 6-9.2KG
Capacity: 1000ML
Solution: neutral (special solution)
Process: oxidation, anti-corrosion treatment
Material: aluminum, plastic
Adaptation temperature: 1-50°
Packing quantity: 12 pcs/carton

UE-FO-147-1

Interior cleaning gun



Working pressure: 6-9.2KG
Capacity: 1000ML
Solution: neutral (special solution)
Process: oxidation, anti-corrosion treatment
Material: aluminum, plastic
Adaptation temperature: 1-50°
Packing quantity: 12 pcs/carton

UE-FO-147-2

Needle gun



Working pressure: 6-9.2KG
Capacity: 1000ML
Solution: neutral (special solution)
Process: oxidation, anti-corrosion treatment
Material: aluminum, plastic
Adaptation temperature: 1-50°
Packing quantity: 12 pcs/carton

Black King Kong Series



Ceiling cleaning gun **UE-FO-147-3**

Working pressure: 6-9.2KG
Capacity: 1000ML
Solution: neutral (special solution)
Process: oxidation, anti-corrosion treatment
Material: aluminum, plastic
Adaptation temperature: 1-50°
Packing quantity: 12 pcs/carton



UE-FO-147-4 Universal cleaning gun

Working pressure: 6-9.2KG
Capacity: 1000ML
Solution: neutral (special solution)
Process: oxidation, anti-corrosion treatment
Material: aluminum, plastic
Adaptation temperature: 1-50°
Packing quantity: 12 pcs/carton



UE-FO-16 Special velvet cleaner

Tornado ceiling cleaning gun: designated dedicated

Tyrant Gold Series



Engine cleaning gun **UE-FO-234**

Working pressure: 6-9.2KG
Process: oxidation, anti-corrosion treatment
Material: aluminum, plastic
Solution: neutral (special solution)
Material: aluminum, plastic
Adaptation temperature: 1-50°
Packing quantity: 10pcs/carton

Motor vehicle testing equipment



UE-15A

Ambient temperature: $-10 \sim 40^{\circ}\text{C}$

rated power: 200W

Relative humidity: $\leq 90\%$

Dimensions: $800 \times 670 \times 1700$ (Length \times width \times height)

Working power: AC $(220 \pm 22)\text{V}$, 50 ± 1 Hz

Instrument weight: 100 kg



UE-16A

Ambient temperature: $-10 \sim 40^{\circ}\text{C}$

Rated power: 9.6W

Standby: 5W

Relative humidity: $\leq 90\%$

Dimensions: $670 \times 611 \times 1837$ mm (L \times W \times H)

Working power: DC 12.6V, 2A

Instrument weight: 80 kg



UE-Z10C

Right Height of lamp: $400 \sim 1300$ mm

Measuring distance: 500 ± 5 mm

Luminous Intensity: $\pm 10\%$

Relative humidity: $\leq 90\%$

DC power supply: DC 12V

Dimensions (L \times W \times H): $680 \times 570 \times 1400$ mm

Horizontal direction: 3° left to 3°

light intensity: $(0 \sim 120000)$ cd

Full Automatic Headlight Tester



UE-6B Full Automatic Headlight Tester

Features

1. The instrument uses high-speed advanced DSP image processing technology and high-definition CCD camera system to achieve automatic detection and adjustment;
2. Precise optical system design, matching the V (λ) curve recommended by the International Illumination Commission, suitable for various types of headlamps (halogen, xenon, LED) and fog lamp type detection (optional), can detect the left exit Rudder model and American standard double turning point low beam type;
3. The test results are consistent with the 10-meter screen method specified by the national standard, which is convenient for users to self-calibrate;
4. Support dual-lamp simultaneous detection mode and online adjustment mode;
5. High-performance industrial computer control, professionally designed "Human-machine dialogue" online adjustment and function setting interface, it is easier and more convenient to adjust the light; dual display system provides dual backup data display;
6. Separate measurement and on-line adjustment of the far and near light, respectively, and the head of the light instrument has no movement when adjusting the light, and the speed and speed of the light adjustment are high;
7. Multi-point auxiliary light search system and special CCD light search method, effectively prevent external light interference;
8. The detection distance is 0.8-1.2 meters, which meets the needs of "flexible" production lines of automobile manufacturers.

Measuring range			
light intensity	(0 ~ 120000) cd		
High beam optical axis offset	Vertical direction	Up 2° 30' ~ down 3°	
	horizontal direction	3° left ~ 3° right	
Low beam optical axis offset	Vertical direction	Up 2° 30' ~ down 3°	
	horizontal direction	3° left to 3° right	
Headlight height	(350 ~ 1400) mm		
Indication error			
light intensity	When the optical axis offset value (angle) is zero, the indicated value error is not greater than ± 10%		
	When the optical axis offset value (angle) is at any value within the test range, the indicated value error is not greater than ± 12%		
High beam optical axis offset	Indication error: no more than ± 3.2cm / dam (± 10°)		
	Difference between indications: not more than ± 3.2cm / dam (± 10°)		
Low beam optical axis offset	Indication error: no more than ± 3.2cm / dam (± 10°)		
Headlight height	Indication error: no more than ± 10mm		
Other parameters			
Working conditions			
Ambient temperature	(-10 ~ 40)°C	rated power	200W Standby: 37W
Relative humidity	≤90%	Dimensions	800×670×1700(Leng th × width × height)
Working power	AC(220±22)V, 50±1)Hz	Instrument weight	100 kg
Guide	5m long, 35kg	Detection time of double lamps	≤25 s
Detection distance	(0.8 ~ 1.2)m		

Motor vehicle exhaust detection equipment



UE-60A

Air pressure:75.0 kPa~110.0kPa
temperature:-5℃~45℃
humidity:<95%
Working power:AC 220V±22V, 50Hz±1Hz
rated power:65W
Dimensions:550×485×230mm
Instrument weight:About 15kg



UE-60B

Air pressure:75.0 kPa~110.0kPa
temperature:-5℃~45℃
humidity:<95%
Working power:AC 220V±22V, 50Hz±1Hz
Power consumption:110W
Dimensions:550×485×230mm
Instrument weight:About 16kg



UE-5115

Air pressure:75.0 kPa~110.0kPa
temperature:-5℃~45℃
humidity:<95%
Working power:AC 220V±22V, 50Hz±1Hz
Power consumption:Host: 110W
Pretreatment: 350W
Dimensions:550×485×230mm
Pre-processing: 530 × 380 × 145mm
Instrument weight:About 15kg
Pretreatment: 12kg



UE-521

Air pressure:75.0 kPa 110.0kPa
temperature:-5 45
humidity: 95%
Working power:AC 220V±22V 50Hz±1Hz
rated power: 45W
Dimensions:240×248×210mm
Instrument weight:About 8kg

Motor vehicle exhaust detection equipment



UE-6011

Air pressure:76.0 kPa~106.0kPa
temperature:0℃~50℃
Relative humidity:≤90%
voltage:AC (380±38) V, frequency50Hz±1Hz
Air volume:2400m³/h
Power consumption:5.5kW
weight:430 kg
noise:< 70dB
Dimensions:1200×970×2140mm



UE-211

Air pressure:60.0KPa~110.0KPa
temperature:-5℃~50℃
Relative humidity:≤95%
Working power:AC 220V±22V, 50Hz±1Hz
rated power:150W
Host computer size:353×248×210 mm
Lower machine size:525×170×332 mm
PC weight:About 5kg
Lower machine weight:About 6kg



UE-110

Air pressure:75.0 kPa~110.0kPa
temperature:-5℃~45℃
Relative humidity:≤95%
Working power:AC 220V±22V, 50Hz±1Hz
power:1000W
Dimensions:1420mm×450mm×900 mm
weight:70kg



UE-212

Air pressure:60.0KPa~110.0KPa
Ambient temperature:-5℃~50℃
Relative humidity:≤95%
Rated voltage:AC 220V/50Hz
rated power:150W
Dimensions:525×170×332 mm
Instrument weight:About 6kg

Automobile chassis dynamometer

UEDCG-3



Rated load quality (kg): 3500
Drum diameter (mm): 216
Roller length (mm): 1000
Drum center distance (mm): 442
Number of roller sets: Two groups
Maximum test speed (km/h): 130
Maximum absorbed power (kW): 250
Power of anti-drag motor (kW): 7.5 (frequency control)
Maximum speed of anti-drag (km/h): >96
Lifting method: Airbag
Measuring speed error (km/h): $\leq \pm 0.1$
Driving force measurement error (%): $\leq \pm 1$
Constant speed control error (km/h): $\leq \pm 0.2$
power supply: AC 220V, 50Hz, 30A/AC 380V, 50Hz, 10kW
Dimensions (mm): 4000x970x645



UEASM-3

Maximum axle load(kg):3000
Maximum braking torque(N.m):1400
Maximum absorbed power:160
Drive test range:0-5000
Drum diameter × length(mm): $\phi 216 \times 1000$
Roller inner distance × outer distance(mm):650×2650
Drum center distance(mm):434
Maximum test speed(km/h):130
Considerable inertia(kg):908±18
Working pressure(MPa):0.7-0.9
Dimensions(mm):3900×950×400



UEASMLGD-3

Maximum axle load(kg):3000
Maximum braking torque(N.m):1400
Maximum absorbed power:160
Drive test range:0-5000
Drum diameter × length(mm): $\phi 216 \times 1000$
Roller inner distance × outer distance(mm):650×2650
Drum center distance(mm):434
Maximum test speed(km/h):130
Considerable inertia(kg):908±18
Working pressure(MPa):0.7-0.9
Dimensions(mm):3900×950×400

Automobile chassis dynamometer

UELGD-3

Maximum axle load(kg):3000
Maximum braking torque(N.m):1400
Maximum absorbed power:160
Drive test range:0-5000
Drum diameter × length(mm): $\phi 216 \times 1000$
Roller inner distance × outer distance(mm):650×2650
Drum center distance(mm):434
Maximum test speed(km/h):130
Considerable inertia(kg):908±18
Working pressure(MPa):0.7-0.9
Dimensions(mm):3900×950×400



UELGD-13

Maximum axle load(kg):3000
Maximum braking torque(N.m):1400
Maximum absorbed power:160
Drive test range:0-5000
Drum diameter × length(mm): $\phi 216 \times 1000$
Roller inner distance × outer distance(mm):650×2650
Drum center distance(mm):434
Maximum test speed(km/h):130
Considerable inertia(kg):908±18
Working pressure(MPa):0.7-0.9
Dimensions(mm):3900×950×400



UE-VMAS

Maximum axle load(kg):3000
Maximum braking torque(N.m):1400
Maximum absorbed power:160
Drive test range:0-5000
Drum diameter × length(mm): $\phi 216 \times 1000$
Roller inner distance × outer distance(mm):650×2650
Drum center distance(mm):434
Maximum test speed(km/h):130
Considerable inertia(kg):908±18
Working pressure(MPa):0.7-0.9
Dimensions(mm):3900×950×400



Motor vehicle inspection line



UE-CH

Model:UE-CH-3
Maximum axle load(kg):3000
Wheel track (inside width/outside width) (mm):700/2400
Detection range (m/km): ± 15
Skateboard size (mm):850 \times 500
Dimensions (mm):2700 \times 660 \times 200



UE-CS

Maximum axle load(kg):3000
Wheel track (inside width/outside width) (mm):700/2400
Detection speed (km/h):0-120
Drum diameter \times length (mm): $\Phi 190 \times 850$
Dimensions (L \times W \times H) (mm):2700 \times 850 \times 400



UE-FZ-3-4WD

Maximum axle load mass:3t
Lifting stroke of anti-return mechanism:150mm
Difference between braking force indications: $\leq 1\%$
Brake drum diameter \times length:245 \times 800mm
Free roller diameter \times length:155 \times 800mm



UE-FZ-3-ABS

Index value(daN):2
Indication error(%): ± 3
Drum diameter(mm):245
Drum surface linear speed(km/h):2.5 \sim 10
Power supply, V/air pressure(Mpa):AC380 $\pm 10\%$ /0.7
Wheelbase detection range(mm):2200 \sim 3300
Self-weight(t):5

Motor vehicle inspection line



UE-FZ

Model:UEFZ-3
Maximum allowable axle load mass (kg):3000
Braking force test range (kN):2×(0---10)
Detection speed (km/h):2.5
Drum diameter × length (mm):Φ245×850
Motor power (KW):2×3
power supply:380V 50Hz
Dimensions (mm):2900×870×350



UE-JX-10

Project:UEJX-10/13
Maximum axle load mass:10t/13t (dual platform)
Maximum wheel mass:5t/6.5t (each platform)
Countertop size:1000mm×750mm
Maximum displacement of table top:100mm×100mm
Maximum displacement of table:23kN
Power supply:3 phase 380V / 220V 50Hz 10A



UE-JZ

Project:UEJZ-13
Maximum load quality:13000 kg
Braking force detection range:0-39000 N×2
Sticky roller diameter:Φ245 (mm)
Dimensions (L×W×H):5015×1340×960 (mm)
Motor power of brake table:11 kW×2
Motor powe:AC 3 phase 380 V / 50 Hz, with ground



UE-LZ-30

Maximum load quality:15000 kg×2
Carrier board dimensions (single board):4000×1000 (mm)
Weight of bearing board (single board):800 kg
Dimensions (single side):4000×1000×210 (mm)
Use ambient temperature:0-40 °C

Motor vehicle inspection line



UE-LZ

Model:LZ-3
Maximum allowable axle load (kg):3000
Wheel track (inside width/outside width) (mm):
700 (inner)/2400 (outer)
Detection range (kg):0-3000
Dimensions (mm):2700×660×200



UE-PB

Model:PB-2
Maximum allowable wheel load (kg):1500
Braking force measurement range (N):0-12500X2
Wheel weight measuring range (kg):0-1500
Side slip measurement range (m/km):±15.0
Dimensions (mm):1950x700x65
Equipment weight (kg):250
Dimensions of side slide (mm):600x500
Test speed (km/h):10-May
Voltage:AC 220V, 50Hz, ground



UE-XX-3

Allowable load (kg):3000
Excitation frequency (Hz): $\cong 23$
Absorption rate repeat error: $\cong 2\%$
Axle load indication error: $\cong 2\%$
Motor power (KW):2×2.2
Dimensions (mm):2400×440×335



UE-ZG

Model:UEZG-10
Maximum allowable axial load (kg):10000
Roller size (mm):190x1000
Air pressure (MPa):0.7-0.8
Solenoid valve power supply:AC 220V, 50Hz, with ground

Motor vehicle inspection line



UE-ZJ-10-13

Maximum allowable axle load (kg):10000/13000
examination range: $\pm 5^{\circ}$
Wheel track (inside width/outside width) (mm):700/2700
Indication error of kingpin: 0.2°
Backward tilt error of main pin: 0.2°
Wheel camber error: 0.2°
Indication error of maximum wheel angle: 0.2°
Toe indication error (mm):0.5
Turntable moving speed (mm/s):15.5
Dimensions (mm):3800×880×420



HCGT-3-4W

Model:HCGT-3-4W
The maximum test load:3.0T
Volume:2
Weight:1500kg



HCGT-3-3

Model:HCGT-3-3
The maximum test load:3.0T
Volume:2
Weight:1500kg

Auto Steering Angle Detector



UE-10

Maximum allowable axle load mass (kg): 10000
Resolution (mm): 0.1
examination range: ± 50
Turntable moving speed (mm/s): 15.5
Front wheel track (inner width/outer width) (mm): 1100/2300
Weight (kg): 850

Cleaning machine



UE-8900 Automobile A/C pipeline cleaning machine

voltage: DC 12vor AC220V 50HZ
Air pressure: 20-60PSI
power: 0.18kw
weight: 40kg
Length: 49cm
Width: 39cm
Height: 102cm



UE-8502 Engine cooling system cleaning machine

Working air pressure: 40- 100 PSI
Weight: 21kg
Length: 44cm
Width: 33cm
Height: 107.5cm



UE-84B Fuel injector cleaner & analyzer

Voltage: AC220V 50Hz
System pressure: 0-5kg/cm²
Length: 46cm
Width: 50cm
Height: 128cm
Weight: 49kg
Ultrasonil washing power: 70w
Ultrasonilwashing frequency: 28kHz±0.5kHz
Cylinder capacity: 140ml
Cylinderretiles accuracy: 2ml



UE-8600D Automatic transmission changer machine

Power: 0.35kw
Voltage: DC12V
Weight: 62kg
Length: 60.5cm
Width: 50cm
Height: 114cm

Cleaning machine



UE-86A Fuel injector cleaner & analyzer

Voltage: AC220V 50Hz
System pressure: 0-5kg/cm²
Length: 68cm
Width: 46cm
Height: 135cm
Weight: 117kg
Ultrasonic washing power: 70w
Ultrasonic washing frequency: 28kHz±0.5kHz
Cylinder capacity: 140ml
Cylinder retiles accuracy: 2ml



UE-88B Fuel injector cleaner & analyzer

Voltage: AC220V 50Hz
System pressure: 0-5kg/cm²
Length: 67cm
Width: 54cm
Height: 132cm
Weight: 120kg
Ultrasonic washing power: 70w
Ultrasonic washing frequency: 28kHz±0.5kHz
Cylinder capacity: 140ml
Cylinder retiles accuracy: 2ml



UE-8200 Engine fuel system cleaning machine

Voltage: AC 220V 50Hz or DC 12V
Power: 0.18kw
Weight: 40kg
Length: 49cm
Width: 39cm
Height: 102cm



UE-8800 The power steering machine

Voltage: DC 12V or AC 220V 50Hz
Power: 0.36kw
Weight: 40kg
Length: 49cm
Width: 39cm
Height: 102cm

Cleaning machine



UE-8300 Engine fuel system cleaning machine

Power: 0.18kw
Voltage: AC 220V 50Hz or DC 12V
Weight: 40kg
Length: 49cm
Width: 39cm
Height: 102cm



UE-8802 The power steering machine

Working air pressure: 40-100PSI
Weight: 20kg
Length: 49cm
Width: 39cm
Height: 102cm



UE-8302 Engine lubricating oil system cleaning machine

Working air pressure: 40-100PSI
Weight: 40kg
Length: 49cm
Width: 39cm
Height: 102cm



UE-8500 Engine cooling system cleaning machine

Working air pressure: 20- 60 PSI
Power: 0.18kw
Voltage: AC 220V 50Hz or DC 12V
Weight: 40kg
Length: 49cm
Width: 39cm
Height: 102cm

Cleaning machine



UE-8501 Engine cooling system cleaning machine

Working air pressure: 40-100PSI
Weight: 21kg
Length: 44cm
Width: 33cm
Height: 107.5cm



UE-8502 Engine cooling system cleaning machine

Working air pressure: 40-100PSI
Weight: 40kg
Length: 49cm
Width: 39cm
Height: 102cm



UE-8600 Automatic transmission changer machine

Voltage: AC 220V 50Hz or DC 12V
Power: 0.1 8kw
Weight: 40kg
Length: 49cm
Width: 39cm
Height: 102cm



UE-8601 Automatic transmission changer machine

Working air pressure: 40-100PSI
Weight: 28.5kg
Length: 50.5cm
Width: 44.5cm
Height: 97cm

Cleaning machine



UE-8602 Automatic transmission changer machine

Working air pressure: 40-100PSI
Weight: 28.5kg
Length: 49cm
Width: 39cm
Height: 102cm



UE-8700 Brake oil changing machine

Power: 0.18kw
Voltage: AC 220V 50Hz or DC 12V
Vacuumdegree: 0-(minus)0.08Mpa
Weight: 38kg
Length: 49cm
Width: 39cm
Height: 102cm



UE-8701 Brake oil changing machine

Workingair Pressure: 40-100PSI
Weight: 18.5kg
Length: 44cm
Width: 33cm
Height: 107.5cm
Vacuumdegree: 0-(minus)0.08Mpa



UE-8801 The power steering machine

Working air pressure: 40-100PSI
Weight: 20kg
Length: 44cm
Width: 33cm
Height: 107.5cm

Cleaning machine



UE-82201 Spray gun washer

working air pressure: 60-100PSI
Weight: 36kg
Length: 65.3cm
Width: 47.5cm
Height: 101.4 cm

Waste oil machine



UE-83197 Collecting oil machine

Vacuum degree: 0-(minus)0.08mpa
Air pressure: 8-10kg/cm²
Oil tank capacity: 72L
Oil basin capacity: 10L
Medium: Lubricating oil
Graduate Cup: 10L
Φ(4.5mm) collecting speed: 0.8L/m1n
Φ(6.5mm) collecting speed: 1.6L/min
Weight: 30kg
The greatest pressure: 4kg/cm²



UE-83027 Collecting oil machine

Vacuum degree: 0-(minus)0.08mpa
Air pressure: 8-10kg/cm²
Oil tank capacity: 24L
Oil basin capacity: 10L
Medium: Lubricating oil
Graduate Cup: 10L
Φ(4.5mm) collecting speed: 0.8L/m1n
Φ(6.5mm) collecting speed: 1.6L/min
Weight: 17kg
The greatest pressure: 4kg/cm²

Waste oil machine



UE-82324 Lubricating oil filer

Air pressure: 1-3kg/cm²
The greatest pressure: 4 kg/cm²
Oil tank capacity: 24L
Medium: Lubricating oil, gear wheel oil
Weight: 12.5kg



UE-83090 Collecting oil machine

Vacuum degree: 0-(minus)0.08mpa
Air pressure: 8-10kg/cm²
Oil tank capacity: 72L
Medium): Lubricating oil
Graduate Cup: 10L
Φ4.5mm collecting speed: 0.8L/min
Φ(6.5mm collecting speed: 1.6L/min
Weight: 24kg
The greatest pressure: 4kg/cm²



UE-83194 Collecting oil machine

Vacuum degree: 0-(minus)0.08mpa
Air pressure: 8-10kg/cm²
Oil tank capacity: 72L
Medium): Lubricating oil
Graduate Cup: 10L
Φ4.5mm collecting speed: 0.8L/min
Φ(6.5mm collecting speed: 1.6L/min
Weight: 25.5kg
The greatest pressure: 4kg/cm²



UE-8380 Foam washing machine

Air pressure: 1-2.5bar
Weight: 19kg
Capacity: 72L
The greatest pressure: 3bar

Waste oil machine



UE-82990 Pumping and filling machine

Air pressure: 1-3kg/cm²
The greatest pressure: 4kg/cm²
Oil tank capacity: 24L
Medium: Lubricating oil, gear wheel oil
Weight: 15.5kg
Accuracy: +0.5%



UE-82991 Minibus pneumatic lubricating oil filler

ART 2296: Electronic volume readout
ART 28702: Connect pipe
ART20205: oil pump
Weight: 35.5kg
Length: 87cm
Width: 64cm
Height: 1045cm
Air pressure: 4- 8kg/cm²
Accuracy: +0.5%

Cleaner



high efficiency manual

System: gearbox system
transmission protector
Number: WA59419
Packing: 24 * 120 ml



advanced power steering

System: power steering system
protection agent
Number: WA64805
Packing: 24 * 120 ml



super powerful protective

System: lubrication system
agent for engine
Number: WA64328a
Packing: 24 * 325 ml



engine wear protection agent

System: functional products
Number: WA63614a
Packing: 24 * 325 ml



advanced power steering protection agent

System: power steering system
Number: WA64805
Packing: 24 * 120 ml



anti-leakage protective agent for cooling system

System: cooling system
Number: WA19201
Packing: 24 * 325 ml



oil system liquid gold cleaning protectant

System: fuel system
Number: WA66201
Packing: 24 * 325 ml



brake hub lubrication protector

System: brake system
Number: WA4501c
Packing: 24 * 10 g



special effect three - way catalytic converter cleaning agent

System: ternary system
Number: WA66101
Packing: 24 * 325 ml

Tunnel light series



UE-E1006

Suitable for beauty station

Size: 5330*4000*2615mm
Voltage: DC24V —AC220V
Light-emitting surface: 240mm light on three sides
Power: 66W/M
Lumen: 110- 120lm/w
CRI: >85
Color temperature: Positive white (5500-6000K)
Lifespan: 50000H, 2 years warranty



UE-E1007

Suitable for beauty station

Size: 6140*4000*2615mm
Voltage: DC24V —AC220V
Light-emitting surface: Column 240mm front light emitting / horizontal 600mm front light emitting
Power: 66W/M
Lumen: 110- 120lm/w
CRI: >96
Color temperature: White/warm
Lifespan: 50000H, 2 years warranty



UE-E1009

Suitable for beauty station

Size: 5650*4000*2615mm
Voltage: DC24V —AC220V
Light-emitting surface: 100mm light on three sides
Power: 32W/M
Lumen: 110- 120lm/w
CRI: >85
Color temperature: Positive white (5500-6000K)
Lifespan: 50000H, 2 years warranty



UE-E1010

Suitable for beauty station

Size: 5751*4000*2615mm
Voltage: DC24V —AC220V
Light-emitting surface: Column 100mm three-sided light / horizontal 240mm front light
Power: 32W/M
Lumen: 110- 120lm/w
CRI: >85
Color temperature: Positive white (5500-6000K)
Lifespan: 50000H, 2 years warranty

Tunnel light series



UE-E1011

Suitable for beauty station

Size: 5242*4000*2615mm
Voltage: DC24V —AC220V
Light-emitting surface: 40mm light on three sides
Power: 24W/M
Lumen: 110- 120lm/w
CRI: >85
Color temperature: Positive white (5500-6000K)
Lifespan: 50000H, 2 years warranty



UE-E1013

Suitable for beauty station

Size: 1600*4000mm
Voltage: DC24V —AC220V
Light-emitting surface: Front light
Power: Soft film lamp 600W, pattern catching lamp 50W/pc
Lumen: 100- 110lm/w
CRI: >70
Color temperature: Zhengbai
Lifespan: 50000H, 2 years warranty



UE-E1015

Suitable for beauty station

Size: 5370*4000*2615mm
Voltage: DC24V —AC220V
Light-emitting surface: Column 100mm light on three sides / horizontal 600mm light on front
Power: 32W/M
Lumen: 110- 120lm/w
CRI: >85
Color temperature: Positive white (5500-6000K)
warm white (3500-4000K)
Lifespan: 50000H, 2 years warranty



UE-E2015

Suitable for beauty station

Size: 5037*4000*2615mm
Voltage: DC24V —AC220V
Light-emitting surface: Column 100mm light on three sides / horizontal 600mm light on front
Power: 32W/M
Lumen: 110- 120lm/w
CRI: >85
Color temperature: Five color temperature segment conversion 6500K/5500K/4500K/4000K/2700K
Lifespan: 50000H, 2 years warranty

Nine Palace Lamp Series



UE-E1016-1

Suitable for beauty station

Voltage: AC220V

Light-emitting surface: Front light

Power: Jiugong grid 765W, pattern catching lamp 50W/pc

Lumen: 110- 120lm/w

CRI: >90

Color temperature: Positive white (5500-6000K)

Lifespan: 50000H, 2 years warranty



UE-E1016-2

Suitable for beauty station

Voltage: AC220V

Light-emitting surface: Front light

Power: Jiugong grid 765W, pattern catching lamp 50W/pc

Lumen: 110- 120lm/w

CRI: >90

Color temperature: Positive white (5500-6000K)

Lifespan: 50000H, 2 years warranty



UE-E1016-3

Suitable for beauty station

Voltage: AC220V

Light-emitting surface: Front light

Power: Jiugong grid 765W, pattern catching lamp 50W/pc

Lumen: 110- 120lm/w

CRI: >90

Color temperature: Positive white (5500-6000K)

Lifespan: 50000H, 2 years warranty



UE-E1016

Suitable for beauty station

Voltage: AC220V

Light-emitting surface: Front light

Power: 765W

Lumen: 110- 120lm/w

CRI: >90

Color temperature: Positive white (5500-6000K)

Lifespan: 50000H, 2 years warranty

Nine Palace Lamp Series



UE-E2016

Suitable for beauty station

Voltage: AC220V

Light-emitting surface: Front light / five-tone light

Power: 765W

Lumen: 110- 120lm/w

CRI: >90

Color temperature: Five color temperature segment conversion 6500K/5500K/4500K/4000K/2700K

Lifespan: 50000H, 2 years warranty



UE-E3016-12A

Suitable for beauty station

Size: 3646mm*2435mm / 【4*3】 12 grids

Voltage: AC220V

Light-emitting surface: Front light

Power: 1020W

Lumen: 110- 120lm/w

CRI: >90

Color temperature: Monochrome, pure white (5500-6000K)

Lifespan: 50000H, 2 years warranty



UE-E3016-12B

Suitable for beauty station

Size: 3646mm*2435mm / 【4*3】 12 grids

Voltage: AC220V

Light-emitting surface: Front light

Power: 1020W

Lumen: 110- 120lm/w

CRI: >90

Color temperature: Five color temperature segment conversion 6500K/5500K/4500K/4000K/2700K

Lifespan: 50000H, 2 years warranty



UE-E3016-16A

Suitable for beauty station

Size: 4854mm*2435mm / 【4*4】 16 grids

Voltage: AC220V

Light-emitting surface: Front light

Power: 1360W

Lumen: 110- 120lm/w

CRI: >90

Color temperature: Monochromatic light, pure white (5500-6000K)

Lifespan: 50000H, 2 years warranty

Nine Palace Lamp Series



UE-E3016-16B

Suitable for beauty station

Size: 4854mm*2435mm / 【4*4】 16 grids

Voltage: AC220V

Light-emitting surface: Front light

Power: 1360W

Lumen: 110- 120lm/w

CRI: >90

Color temperature: Five color temperature segment conversion 6500K/5500K/4500K/4000K/2700K

Lifespan: 50000H, 2 years warranty



UE-E5016-A

Suitable for beauty station

Size: 4854mm*2435mm / 【4*4】 4 grids

Voltage: AC220V

Light-emitting surface: Front light

Power: 1360W

Lumen: 110- 120lm/w

CRI: >90

Color temperature: Monochrome, pure white (5500-6000K)

Lifespan: 50000H, 2 years warranty



UE-E5016-B

Suitable for beauty station

Size: 4854mm*2435mm / 【4*4】 4 grids

Voltage: AC220V

Light-emitting surface: Front light

Power: 1360W

Lumen: 110- 120lm/w

CRI: >90

Color temperature: Five color temperature segment conversion 6500K/5500K/4500K/4000K/2700K

Lifespan: 50000H, 2 years warranty

Maintenance station series



UE5098

Suitable for maintenance stations

Size: 2542*4893mm
Voltage: AC220V
Light-emitting surface: 80mm light on three sides
Power: 539W
Lumen: 110- 120lm/w
CRI: >95
Color temperature: Positive white (5500-6000K)



UE-C80

Suitable for maintenance stations

Size: 2542*4893mm
Voltage: AC220V
Light-emitting surface: 80mm light on three sides
Power: 360W
Lumen: 110- 120lm/w
CRI: >95
Color temperature: Positive white (5500-6000K)



UE-C100

Suitable for maintenance stations

Size: 2400*4800mm
Voltage: DC24V-AC220V
Light-emitting surface: 100mm light on three sides
Power: 1280W
Lumen: 110- 120lm/w
CRI: >90
Color temperature: Positive white (5500-6000K)
Lifespan: 50000H, 2 years warranty



UE-C240

Suitable for maintenance stations

Size: 2400*4800mm
Voltage: DC24V-AC220V
Light-emitting surface: 240mm light on three sides
Power: 66W/M
Lumen: 110- 120lm/w
CRI: >95
Color temperature: Positive white (5500-6000K)
Lifespan: 50000H, 2 years warranty

Maintenance station series



UE-2048

Suitable for maintenance stations

Size: 2410*4780mm
Voltage: AC220V
Light-emitting surface: 20mm light on three sides
Power: 508W
Lumen: 110- 120lm/w
CRI: >90
Color temperature: Positive white (5500-6000K)
Lifespan: 50000H, 2 years warranty



UE-2058

Suitable for maintenance stations

Size: 2410*4780mm
Voltage: AC220V
Light-emitting surface: 20mm light on three sides
Power: 340W
Lumen: 110- 120lm/w
CRI: >90
Color temperature: Positive white (5500-6000K)
Lifespan: 50000H, 2 years warranty



UE-A40

Suitable for maintenance stations

Size: 2800*4700mm
Voltage: DC24V-AC220V
Light-emitting surface: 40mm light on three sides
Power: 24W/M
Lumen: 110- 120lm/w
CRI: >80
Color temperature: Positive white (5500-6000K)
Lifespan: 50000H, 2 years warranty



UE-B40

Suitable for maintenance stations

Size: 2800*4700mm
Voltage: DC24V-AC220V
Light-emitting surface: 40mm light on three sides
Power: 24W/M
Lumen: 110- 120lm/w
CRI: >80
Color temperature: Positive white (5500-6000K)
Lifespan: 50000H, 2 years warranty

Beauty cleaning station series



UE-5018 Suitable for beauty station

Size: 2542*4893mm
Voltage: AC220V
Light-emitting surface: 80mm light on three sides
Power: 760W
Lumen: 110- 120lm/w
CRI: >95
Color temperature: Positive white (5500-6000K)
Lifespan: 50000H, 2 years warranty



UE-5028 Suitable for beauty station

Size: 2542*4893mm
Voltage: AC220V
Light-emitting surface: 80mm light on three sides
Power: 830W
Lumen: 110- 120lm/w
CRI: >95
Color temperature: Positive white (5500-6000K)
Lifespan: 50000H, 2 years warranty



UE-5058 Suitable for beauty station

Size: 2542*4893mm
Voltage: AC220V
Light-emitting surface: 80mm light on three sides
Power: 638W
Lumen: 110- 120lm/w
CRI: >95
Color temperature: Positive white (5500-6000K)
Lifespan: 50000H, 2 years warranty



UE-5068 Suitable for beauty station

Size: 2542*4893mm
Voltage: AC220V
Light-emitting surface: 80mm light on three sides
Power: 658W
Lumen: 110- 120lm/w
CRI: >95
Color temperature: Positive white (5500-6000K)
Lifespan: 50000H, 2 years warranty

Beauty cleaning station series



UE-5078

Suitable for beauty station

Size: 2350*4710mm
Voltage: AC220V
Light-emitting surface: 80mm light on three sides
Power: 600W
Lumen: 110- 120lm/w
CRI: >95
Color temperature: Positive white (5500-6000K)
Lifespan: 50000H, 2 years warranty



UE-5088

Suitable for beauty station

Size: 2542*4893mm
Voltage: AC220V
Light-emitting surface: 80mm light on three sides
Power: 830W
Lumen: 110- 120lm/w
CRI: >95
Color temperature: Positive white (5500-6000K)
Lifespan: 50000H, 2 years warranty

Fine washing station series



UE-6028

Suitable for beauty station

Size: 2410mm*4780mm
Voltage: AC220V
Light-emitting surface: 20mm
Power: 552W
Lumen: 110- 120lm/w
CRI: >90
Color temperature: Positive white (5500-6000K)
Lifespan: 50000H, 2 years warranty



UE-1048

Suitable for beauty station

Size: 2410mm*4780mm
Voltage: AC220V
Light-emitting surface: 20mm
Power: 504W
Lumen: 110- 120lm/w
CRI: >90
Color temperature: Positive white
Lifespan: 50000H, 2 years warranty

Fine washing station series



UE-1058

Suitable for beauty station

Size: 2410mm*4780mm
Voltage: AC220V
Light-emitting surface: 20mm
Power: 504W
Lumen: 110- 120lm/w
CRI: >90
Color temperature: Positive white
Lifespan: 50000H, 2 years warranty



UE-1068

Suitable for beauty station

Size: 2410mm*4780mm
Voltage: AC220V
Light-emitting surface: 20mm
Power: 426W
Lumen: 110- 120lm/w
CRI: >90
Color temperature: Positive white
Lifespan: 50000H, 2 years warranty

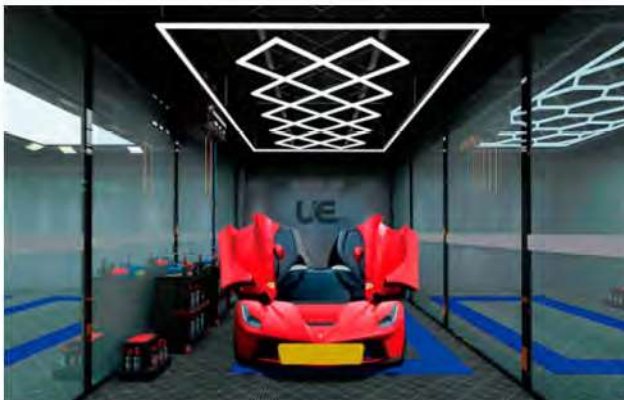

UE-2017

Suitable for beauty station

Size: 2410mm*4780mm
Voltage: AC220V
Light-emitting surface: 20mm
Power: 432W
Lumen: 110- 120lm/w
CRI: >90
Color temperature: Positive white
Lifespan: 50000H, 2 years warranty



UE-1028

Suitable for beauty station

Size: 2410mm*4780mm
Voltage: AC220V
Light-emitting surface: 20mm light on three sides
Power: 552W
Lumen: 110- 120lm/w
CRI: >95
Color temperature: Positive white(5500-6000K)
Lifespan: 50000H, 2 years warranty

Fine washing station series



UE-1088

Suitable for beauty station

Size: 2985*4780mm
Voltage: AC220V
Light-emitting surface: 20mm light on three sides
Power: 552W
Lumen: 110- 120lm/w
CRI: >90
Color temperature: Positive white(5500-6000K)
Lifespan: 50000H, 2 years warranty

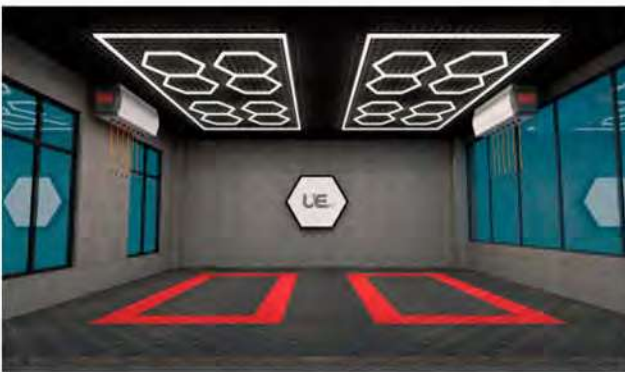

UE-1018

Suitable for beauty station

Size: 2410mm*4780mm
Voltage: AC220V
Light-emitting surface: 20mm
Power: 456W
Lumen: 110- 120lm/w
CRI: >90
Color temperature: Positive white(5500-6000K)
Lifespan: 50000H, 2 years warranty



UE-1038

Suitable for beauty station

Size: 2410mm*4780mm
Voltage: AC220V
Light-emitting surface: 20mm
Power: 456W
Lumen: 110- 120lm/w
CRI: >90
Color temperature: Positive white(5500-6000K)
Lifespan: 50000H, 2 years warranty

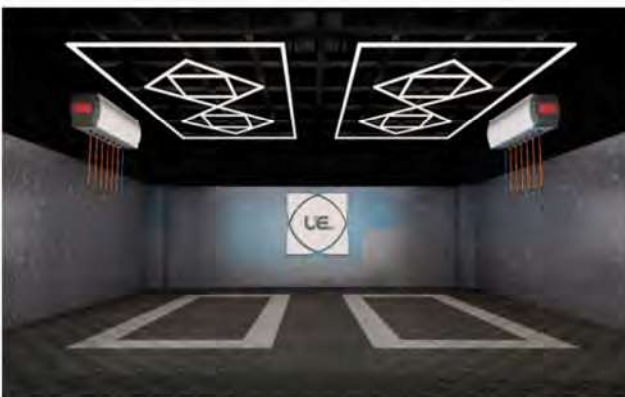

UE-2088

Suitable for beauty station

Size: 2410mm*4780mm
Voltage: AC220V
Light-emitting surface: 20mm
Power: 404W
Lumen: 110- 120lm/w
CRI: >90
Color temperature: Positive white(5500-6000K)
Lifespan: 50000H, 2 years warranty

Fine washing station series



UE-3038

Suitable for beauty station

Size: 2410mm*4780mm
Voltage: AC220V
Light-emitting surface: 20mm
Power: 408W
Lumen: 110- 120lm/w
CRI: >90
Color temperature: Positive white(5500-6000K)
Lifespan: 50000H, 2 years warranty



UE-3048

Suitable for beauty station

Size: 2410mm*4780mm
Voltage: AC220V
Light-emitting surface: 20mm
Power: 564W
Lumen: 110- 120lm/w
CRI: >90
Color temperature: Positive white(5500-6000K)
Lifespan: 50000H, 2 years warranty

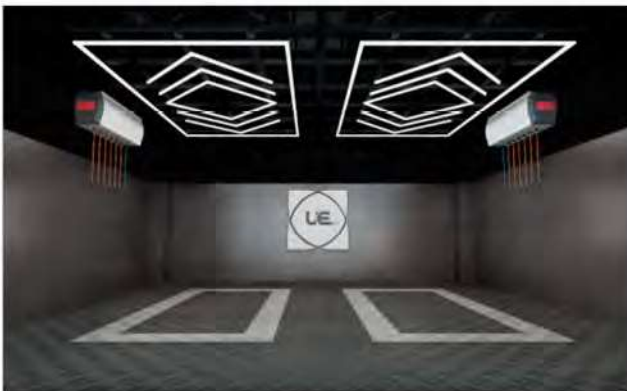

UE-3018

Suitable for beauty station

Size: 2410mm*4780mm
Voltage: AC220V
Light-emitting surface: 20mm
Power: 408W
Lumen: 110- 120lm/w
CRI: >90
Color temperature: Positive white(5500-6000K)
Lifespan: 50000H, 2 years warranty



UE-3028

Suitable for beauty station

Size: 2410mm*4780mm
Voltage: AC220V
Light-emitting surface: 20mm
Power: 408W
Lumen: 110- 120lm/w
CRI: >90
Color temperature: Positive white(5500-6000K)
Lifespan: 50000H, 2 years warranty

Fine washing station series

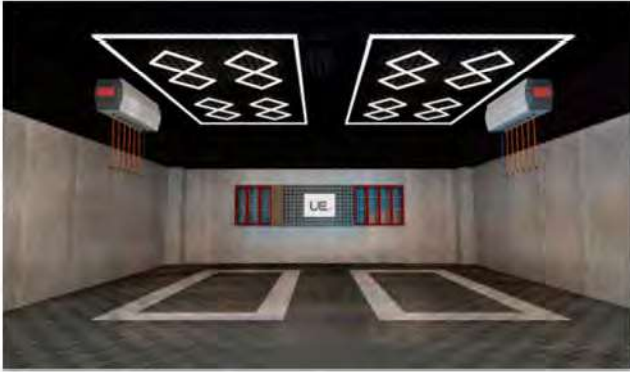

UE-2028

Suitable for beauty station

Size: 2410mm*4780mm
Voltage: AC220V
Light-emitting surface: 20mm
Power: 448W
Lumen: 110- 120lm/w
CRI: >90
Color temperature: Positive white(5500-6000K)
Lifespan: 50000H, 2 years warranty



UE-2038

Suitable for beauty station

Size: 2410mm*4780mm
Voltage: AC220V
Light-emitting surface: 20mm
Power: 864W
Lumen: 110- 120lm/w
CRI: >90
Color temperature: Positive white(5500-6000K)
Lifespan: 50000H, 2 years warranty

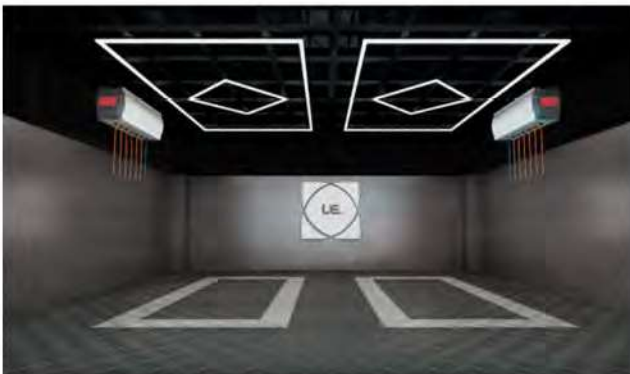

UE-2068

Suitable for beauty station

Size: 2410mm*4780mm
Voltage: AC220V
Light-emitting surface: 20mm
Power: 272W
Lumen: 110- 120lm/w
CRI: >90
Color temperature: Positive white(5500-6000K)
Lifespan: 50000H, 2 years warranty



UE-2078

Suitable for beauty station

Size: 2410mm*4780mm
Voltage: AC220V
Light-emitting surface: 20mm
Power: 306W
Lumen: 110- 120lm/w
CRI: >90
Color temperature: Positive white(5500-6000K)
Lifespan: 50000H, 2 years warranty

Fine washing station series



UE-C203

Suitable for beauty station

Size: 440*934mm/pc
Voltage: AC220V
Light-emitting surface: 20mm
Power: 36W/pc
Lumen: 110- 120lm/w
CRI: >90
Color temperature: Positive white(5500-6000K)
Lifespan: 50000H, 2 years warranty



UE-C503

Suitable for beauty station

Size: 567mm*1152mm
Voltage: AC220V
Light-emitting surface: 80mm
Power: 102W
Lumen: 110- 120lm/w
CRI: >90
Color temperature: Positive white(5500-6000K)
Lifespan: 50000H, 2 years warranty



UE-C204

Suitable for beauty station

Size: 600mm/piece 440mm/piece (optional)
Voltage: AC220V
Light-emitting surface: 20mm
Power: 8W/piece 6W/piece
Lumen: 110- 120lm/w
CRI: >90
Color temperature: Positive white(5500-6000K)
Lifespan: 50000H, 2 years warranty



UE-C205

Suitable for aisle indicator lights

Size: 1178mm*2069mm
Voltage: AC220V
Light-emitting surface: 20mm
Power: 32W/group
Lumen: 110- 120lm/w
CRI: >90
Color temperature: Positive white(5500-6000K)
Lifespan: 50000H, 2 years warranty

Fine washing station series



UE-C505

Suitable for aisle indicator lights

Size: 1175mm*2050mm
Voltage: AC220V
Light-emitting surface: 80mm
Power: 72W
Lumen: 110- 120lm/w
CRI: >90
Color temperature: Positive white(5500-6000K)
Lifespan: 50000H, 2 years warranty



UE-C202

Suitable for beauty station

Size: 600mm/piece 440mm/piece (optional)
Voltage: AC220V
Light-emitting surface: 20mm
Power: 8W/piece 6W/piece
Lumen: 110- 120lm/w
CRI: >90
Color temperature: Positive white(5500-6000K)
Lifespan: 50000H, 2 years warranty

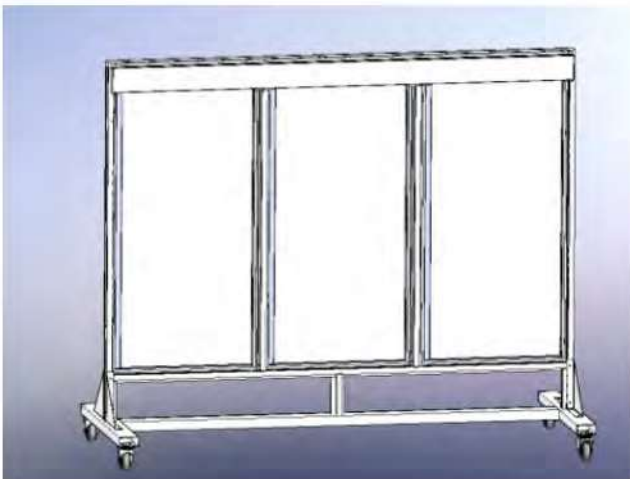

UE-8018

Suitable for beauty station

Size: 1947mm*1499mm
Voltage: AC220V
Light-emitting surface: 20mm
Power: 255W
Lumen: 110- 120lm/w
CRI: >90
Color temperature: Positive white(5500-6000K)
Lifespan: 50000H, 2 years warranty



UE-100

Suitable for beauty station/
commercial photo

Power: 100W
Voltage: AC85-265V 50/60Hz
Lumen: ≥ 120 LM/W
Power Factor: PF > 0.9

Fine washing station series



UE-50

Suitable for beauty station/
commercial photo

Power: 50W
Size: $\Phi 400 \times H250\text{mm}$
Voltage: AC85-265V 50/60Hz
Lumen: 110-120LM/W



UE-51

Suitable for beauty station/
commercial photo

Power: 24W
Size: 540*150mm
Voltage: AC85-265V 50/60Hz
Lumen: 110-120LM/W



Station indicator

Suitable for work position instructions

Size: 38*24*5.5cm
Voltage: AC220V
Light-emitting surface: Front light
Power: 8W
Lumen: 110- 120lm/w
CRI: >90
Color temperature: Positive white(5500-6000K)
Lifespan: 50000H, 2 years warranty

Car paint pattern catching lamp series



UE-8011



UE-8012



UE-8013



UE-8016



UE-8015



UE-8014

Tri-tone light/UE/G8001



All white/UE/G8003

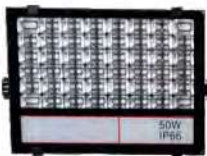

All yellow/UE/G8003

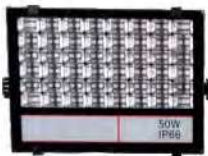

All white/UE/G8002



All yellow UE/G8002



All white/UE/G8005



All yellow/UE/G8005



Specifications

model	UE/G8001	UE/G8003	UE/G8003	UE/G8002	UE/G8002	UE/G8005	UE/G8005
size	276*201*45.3mm	276*201*45.3mm	276*201*45.3mm	285*235*130mm	285*235*130mm	207*237mm	207*237mm
power	50w	50w	50w	50w	50w	50w	50w
Color temperature	3000K/4000k/6500K	6500k	3000k	6500k	3000k	6500k	3000k
light source	SMD2835	SMD2835	SMD2835	LED Imitation Lumen	LED Imitation Lumen	SMD 3030	SMD 3030
Beam angle	120°	120°	120°	120°	120°	120°	120°
Color rendering index	Ra > 95	Ra > 85	Ra > 85	Ra > 85	Ra > 85	Ra > 80	Ra > 80
Lumens	110-130lm/W	100-120lm/W	100-120lm/W	100-120lm/W	100-120lm/W	90-110lm/W	90-110lm/W
chip	Seoul	Seoul	Seoul	Seoul	Seoul	China	China
Protection level	IP65	IP65	IP65	IP65	IP65	IP65	IP65

Electric hydraulic forklift machine



UE-1-1.6

Length*width*height: 1.75*0.8*2.08m
Minimum fork height: 90mm
Lifting height of fork: 1 600mm
Static height : 2080mm
Fork length: 1 100mm
Lifting motor : 2.2KW
Outer width of fork: 680mm
Battery size: 24V/80AH
Self-respect Around : 520KG
Turning radius: 1750mm
Load: 1 ton



UE-1-2

Length*width*height: 1.75*0.8*1.6m
Minimum fork height: 90mm
Lifting height of fork: 2000mm
Length*width*height: 1.75*0.8*1.6m
Minimum fork height: 90mm
Lifting height of fork: 2000mm
Static height : 1600mm
Fork length: 1100mm
Lifting motor: 2.2KW
motor: 0.65KW
Outer width of fork: 680mm
Battery size: 24V/80AH
Self-respect Around : 520KG
Turning radius: 1750mm
Load: 1 ton



UE-1-2.5

Length*width*height: 1.75*0.8*1.85m
Minimum fork height: 90mm
Lifting height of fork: 2500mm
Static height: 1850mm
Fork length: 1100mm
Lifting motor: 2.2KW
motor: 0.65KW
Outer width of fork: 680mm
Battery size: 24V/80AH
Self-respect Around: 520KG
Turning radius: 1750mm
Load: 1 ton

UE-1-3

Length*width*height: 1.75*0.8*2.05m
Minimum fork height: 90mm
Lifting height of fork: 3000mm
Static height: 2005mm
Fork length: 1100mm
Lifting motor : 2.2KW
motor: 0.65KW
Outer width of fork: 680mm
Battery size : 24V/80AH
Self-respect Around : 520KG
Turning radius: 1750mm
Load: 1 ton

Electric hydraulic forklift machine



UE-1-3.5

Length*width*height: 1.75*0.8*2.35m
Minimum fork height: 90mm
Lifting height of fork: 3500mm
Static height: 2350mm
Fork length: 1100mm
Lifting motor: 2.2KW
motor: 0.65KW
Outer width of fork: 680mm
Battery size : 24V/80AH
Self-respect Around : 520KG
Turning radius: 1750mm
Load: 1 ton



UE-1.5-1.6

Length*width*height: 1.75*0.8*2.08m
Minimum fork height: 90mm
Lifting height of fork: 1600mm
Static height: 2080mm
Fork length: 1100mm
Lifting motor : 2.2KW
motor: 0.65KW
Outer width of fork: 680mm
Battery size: 24V/80AH
Self-respect Around: 520KG
Turning radius: 1750mm
Load: 1.5 ton



UE-1.5-2

Length*width*height: 1.75*0.8*1.6m
Minimum fork height: 90mm
Lifting height of fork: 2000mm
Static height : 1 600mm
Fork length: 1100mm
Lifting motor: 2.2KW
motor: 0.65KW
Outer width of fork: 680mm
Battery size: 24V/80AH
Self-respect Around: 520KG
Turning radius: 1750mm
Load: 1.5 ton

UE-1.5-2.5

Length*width*height: 1.75*0.8*1.85m
Minimum fork height: 90mm
Lifting height of fork: 2500mm
Static height: 1850mm
Fork length: 1100mm
Lifting motor : 2.2KW
motor: 0.65KW
Outer width of fork: 680mm
Battery size: 24V/80AH
Self-respect Around : 520KG
Turning radius: 1750mm
Load: 1.5 ton

Electric hydraulic forklift machine



UE-1.5-3

Length*width*height: 1.75*0.8*2.05m
Minimum fork height: 90mm
Lifting height of fork: 3000mm
Static height : 2005mm
Fork length: 1100mm
Lifting motor: 2.2KW
motor: 0.65KW
Outer width of fork: 680mm
Battery size : 24V/80AH
Self-respect Around: 520KG
Turning radius: 1750mm
Load: 1.5 ton

UE-1.5-3.5

Length*width*height: 1.75*0.8*2.35m
Minimum fork height: 90mm
Lifting height of fork: 3500mm
Static height : 2350mm
Fork length: 1100mm
Lifting motor : 2.2KW
motor: 0.65KW
Outer width of fork: 680mm
Battery size : 24V/80AH
Self-respect Around : 520KG
Turning radius: 1750mm
Load: 1.5 ton



UE-2-1.5-1.6

Length*width*height: 2.1*0.86*2.08m
Minimum fork height: 90mm
Lifting height of fork: 1600mm
Static height: 2080mm
Fork length: 1100mm
Lifting motor : 2.2KW
Self-respect Around : 750KG
Turning radius: 1800mm
Load: 1.5 ton



UE-2-1.5-2

Length*width*height: 2.1*0.86*1.6m
Minimum fork height: 90mm
Lifting height of fork: 2000mm
Static height : 1600mm
Fork length: 1100mm
Lifting motor: 2.2KW
Self-respect Around: 750KG
Turning radius: 1 800mm
Load: 1.5 ton

Electric hydraulic forklift machine



UE-2-1.5-2.5

Length*width*height: 2.1*0.86*1.85m
Minimum fork height: 90mm
Lifting height of fork: 2500mm
Static height: 1850mm
Fork length: 1100mm
Lifting motor : 2.2KW
Self-respect Around : 750KG
Turning radius: 1800mm
Load: 1.5 ton

UE-2-1.5-3

Length*width*height: 2.1*0.86*2.05m
Minimum fork height: 90mm
Lifting height of fork: 3000mm
Static height : 2005mm
Fork length: 1100mm
Lifting motor : 2.2KW
Self-respect Around : 750KG
Turning radius: 1800mm
Load: 1.5 ton



UE-2-1.5-3.5

Length*width*height: 2.1*0.86*2.35m
Minimum fork height: 90mm
Lifting height of fork: 3500mm
Static height : 2350mm
Fork length: 1100mm
Lifting motor : 2.2KW
Self-respect Around : 750KG
Turning radius: 1800mm
Load: 1.5 ton



UE-2-2-1.6

Length*width*height: 2.1*0.86*2.08m
Minimum fork height: 90mm
Lifting height of fork: 1600mm
Static height : 2080mm
Fork length: 1100mm
Lifting motor: 2.2KW
Self-respect Around : 750KG
Turning radius: 1800mm
Load: 2 ton

Electric hydraulic forklift machine



UE-2-2-2

Length*width*height: 2.1*0.86*1.6m
Minimum fork height: 90mm
Lifting height of fork: 2000mm
Static height : 1600mm
Fork length: 1100mm
Lifting motor : 2.2KW
Self-respect Around: 750KG
Turning radius: 1800mm
Load: 2 ton



UE-2-2-2.5

Length*width*height: 2.1*0.86*1.85m
Minimum fork height: 90mm
Lifting height of fork: 2500mm
Static height : 1850mm
Fork length: 1100mm
Lifting motor: 2.2KW
Self-respect Around : 750KG
Turning radius: 1800mm
Load: 2 ton



UE-2-2-3

Length*width*height: 2.1*0.86*2.05m
Minimum fork height: 90mm
Lifting height of fork: 3000mm
Static height : 2005mm
Fork length: 1100mm
Lifting motor : 2.2KW
Self-respect Around : 750KG
Turning radius: 1800mm
Load: 2 ton

UE-2-2-3.5

Length*width*height: 2.1*0.86*2.35m
Minimum fork height: 90mm
Lifting height of fork: 3500mm
Static height : 2350mm
Fork length: 1100mm
Lifting motor: 2.2KW
Turning radius: 1800mm
Load: 2 ton

Electric hydraulic forklift machine



UE-4

Length*width*height: 2.1*0.86*2.6m
Minimum fork height: 90mm
Lifting height of fork: 4000mm
Static height :2660mm
Fork length: 1100mm
Lifting motor: 2.2KW
Turning radius: 1800mm



UE-5

Length*width*height: 2.1*0.86*2.27m
Minimum fork height: 90mm
Lifting height of fork: 5000mm
Static height : 2270mm
Fork length: 1100mm
Lifting motor : 2.2KW
Turning radius: 1800mm



UE-1.2-2.7

Length*width*height: 1.66*0.8*1.9m
Minimum fork height: 86mm
Lifting height of fork: 2700-3000mm
Static height : 1900mm
Fork length: 1150mm
Lifting motor : 2.2KW
motor: 0.65KW
Battery size : 24V/85AH
Self-respect Around : 526KG
Turning radius: 1480mm
Load: 1.2 tons

UE-WL3001 Inspection hand lamp



Flashlight	Super bright SMD LED, 130 lumens
Floodlight	Super bright COB LED, 260/620 lumens
Color rendering index	80 CRI+
Color temperature	6500K
Battery capacity	High quality 3.7V 2600mAh Li-ion battery
Floodlight working hours	5h 30mins / 2h 30mins
Waterproof and dustproof	IP54
Drop resistance rating	IK07
Packing QTY.	12pcs
Carton MEAS.	360x285x165mm
Carton G.W.	7.3kg

UE-WL3006 Inspection hand lamp

Flashlight	Super bright SMD LED, 130 lumens
Floodlight	Super bright COB LED, MIN - MAX: 70 - 700 lumens
Color rendering index	80 CRI+
Color temperature	6500K
Battery capacity	High quality 3.7V 2600mAh Li-ion battery
Floodlight working hours	9h 15mins
Waterproof and dustproof	IP54
Drop resistance rating	IK07
Packing QTY.	12pcs
Carton MEAS.	360x265x320mm
Carton G.W.	7.3kg



UE-WL3015 Inspection hand lamp



Floodlight	Super bright SMD LED, 120 lumens
Color rendering index	80 CRI+
Color temperature	6500K
Battery capacity	High quality 3.7V 2600mAh Li-ion battery
Floodlight working hours	12h
Waterproof and dustproof	IP54
Drop resistance rating	IK07
Packing QTY.	12pcs
Carton MEAS.	360x315x290mm
Carton G.W.	6.4kg



UE-WL3020 Inspection hand lamp

Flashlight	Super bright SMD LED, 120 lumens
Floodlight	Super bright COB LED, MIN - MAX: 60 - 700 lumens
Color rendering index	80 CRI+
Color temperature	6500K
Battery capacity	High quality 3.7V 2600mAh Li-ion battery
Floodlight working hours	16h 30mins / 1h 40mins
Charging time	4 hours
Waterproof and dustproof	IP54
Drop resistance rating	IK07
Packing QTY.	20pcs
Carton MEAS.	410x250x200mm
Carton G.W.	8.6kg

UE-WL3110 Inspection hand lamp

Floodlight	Super bright COB LED, 80lumens
Floodlight 1(Front)	Super bright COB LED, 200 / 100lumens
Floodlight 2 (Back)	Super bright COB LED, 180lumens
Color rendering index	80 CRI+
Color temperature	6500K
Battery capacity	High quality 3.7V 700mAh Li-ion battery
Floodlight working hours	2h/4h
Waterproof and dustproof	IP54
Drop resistance rating	IK07
Packing QTY.	48pcs
Carton MEAS.	410x210x235mm
Carton G.W.	6.5kg



UE-WL4010 Inspection hand lamp

Flashlight	Super bright SMD LED, 170 lumens
Floodlight	Super bright COB LED, 150 / 300 / 700 lumens
Color rendering index	80 CRI+
Color temperature	6500K
Battery capacity	High quality 3.7V 2600mAh Li-ion battery
Floodlight working hours	8h / 3h 30mins / 2h
Charging time	4 hours
Waterproof and dustproof	IP65
Drop resistance rating	IK07
Packing QTY.	20pcs
Carton MEAS.	270x255x325mm
Carton G.W.	9.7kg

working lamp



UE-WL4025 Group worklight

Floodlight	Super bright SMD LED
Color rendering index	80 CRI+
Color temperature	6500K
Battery capacity	High quality 14.8V 5200mAh Li-ion battery
Floodlight working hours	2h 30min / 3h 30min / 7h / 13h
Charging time	4h
Waterproof and dustproof	IP54
Drop resistance rating	IK07
Packing QTY.	4pcs
Carton MEAS.	380x335x335mm
Carton G.W.	11.2kg

UE-WL5016 Inspection hand lamp

Floodlight	Super bright SMD LED,120 lumens
Color rendering index	80 CRI+
Color temperature	6500K
Battery capacity	High quality 3.7V 2600mAh Li-ion battery
Floodlight working hours	4h 25mins/ 1h 40mins
Waterproof and dustproof	IP54
Drop resistance rating	IK07
Packing QTY.	12pcs
Carton MEAS.	375x350x210mm
Carton G.W.	6.5kg



UE-WL5018 Flood&Area light

Floodlight	Super bright SMD LED
Min - Max	60 - 1000 lumens
Color rendering index	80 CRI+
Color temperature	6500K
Power bank output	Max 5V 2A
Battery capacity	High quality 3.7V 5200mAh Li-ion battery
Floodlight working hours	24h - 1h 30mins
Charging time	3h 30mins
Waterproof and dustproof	IP54
Drop resistance rating	IK07
Packing QTY.	12pcs
Carton MEAS.	330x260x300mm
Carton G.W.	8.1kg

UE-WL6011 Inspection hand lamp



Floodlight	Super bright SMD LED, 100/300 lumens
Color rendering index	80 CRI+
Color temperature	6500K
Battery capacity	High quality 3.7V 1500mAh Li-Po battery
Floodlight working hours	8h 30mins / 3h
Charging time	2 hours
Waterproof and dustproof	IP54
Drop resistance rating	IK07
Packing QTY.	36pcs
Carton MEAS.	290x230x285mm
Carton G.W.	9.4kg

UE-WL6016 Flood&Area light

Spotlight	Super bright COB LED 250lumens
Floodlight	Super bright COB LED 700 / 350 / 100 lumens
Color rendering index	80 CRI+
Color temperature	6500K
Battery capacity	High quality 3.7V 2600mAh Li-ion battery
Floodlight working hours	2.5h / 5h /14h
Charging time	4h
Waterproof and dustproof	IP65
Drop resistance rating	IK07
Packing QTY.	24pcs
Carton MEAS.	325x315x250mm
Carton G.W.	7.6kg



UE-WL6017 Flood&Area light



Spotlight	Super bright COB LED 400lumens
Floodlight	Super bright COB LED 1400 / 700 / 350 lumens
Color rendering index	80 CRI+
Color temperature	6500K
Battery capacity	High quality 3.7V 5200mAh Li-ion battery
Floodlight working hours	3h / 7h /14h
Charging time	4h 30mins
Waterproof and dustproof	IP65
Drop resistance rating	IK07
Packing QTY.	12pcs
Carton MEAS.	320x190x275cm
Carton G.W.	7kg

working lamp

UE-FS03

Lycolor light Quick color controller Motion Sensor Switch



Floodlight	Super bright , high CRI and multi CCT COB LED 300 / 600 / 1200 / 1800 / 2400lm
Color rendering index	96 CRI+
CCT	2700K-3500K-4500K-5500K-6500K
Battery capacity	High quality 11.1V 5200mAh Li-ion battery
Runtime	13h / 6.5h / 3h / 2h / 1.7h
Charging time	3h 30mins
Waterproof and dustproof	IP65
Drop resistance rating	IK07
Packing QTY.	1pcs
Carton MEAS.	625x420x172mm
Carton G.W.	6.8kg

UE-HL001 Head lamp

Floodlight	Super bright COB LED 100/300 lumens
Color rendering index	80 CRI+
CCT	6500K
Battery capacity	High quality 3.7V 1500mAh Li-Po battery
Charging time	2h 30mins
Waterproof and dustproof	IP65
Drop resistance rating	IK07
Packing QTY.	40pcs
Carton MEAS.	455x285x290mm
Carton G.W.	8.7kg



UE-HL002 Head lamp

Floodlight	Super bright High CRI and three CCT COB LED 160 lumens
Color rendering index	96 CRI+
CCT	2700K-4500K-6500K
Battery capacity	High quality 3.7V 1500mAh Li-Po battery
Charging time	3h
Waterproof and dustproof	IP65
Drop resistance rating	IK07
Packing QTY.	40pcs
Carton MEAS.	455x285x290mm
Carton G.W.	8.7kg



working lamp



UE-PL012 Inspection hand lamp

Flashlight	Super bright SMD LED, 100 lumens
Floodlight	Super bright SMD LED, 120 lumens
Color rendering index	80 CRI+
CCT	6500K
Battery capacity	High quality 3.7V 750mAh Li-ion battery
Charging time	2h 30mins
Waterproof and dustproof	IP20
Drop resistance rating	IK07
Packing QTY.	48pcs
Carton MEAS.	410x210x235mm
Carton G.W.	5.8kg

UE-WL3018 Flood&Area light

Floodlight	Super bright SMD LED 750 / 1500 / 3000 lumens
Color rendering index	80 CRI+
Color temperature	6500K
Power bank output	Max 5V 2A
Battery capacity	High quality 7.4V 5200mAh Li-ion battery
Runtime	8h / 4h / 2h
Charging time	4.5h
Waterproof and dustproof	IP65
Drop resistance rating	IK07
Packing QTY.	4pcs
Carton MEAS.	535x385x240mm
Carton G.W.	8.6kg



UE-WL4016 Flood&Area light



Floodlight	Super bright SMD LED 250 / 500 / 1000 lumens
Color rendering index	80 CRI+
Color temperature	6500K
Battery capacity	High quality 3.7V 5200mAh Li-ion battery
Runtime	8h 30mins / 4h / 2h
Charging time	7h
Waterproof and dustproof	IP65
Drop resistance rating	IK07
Packing QTY.	8pcs
Carton MEAS.	395x300x230mm
Carton G.W.	7.8kg

working lamp



UE-WL4018 Flood&Area light

Floodlight	Super bright SMD LED 500 / 1000 / 2100 lumens
Color rendering index	80 CRI+
Color temperature	6500K
Battery capacity	High quality 11.1V 5200mAh Li-ion battery
Runtime	10h 30mins / 5h 30mins / 3h
Charging time	3h 30mins
Waterproof and dustproof	IP65
Drop resistance rating	IK07
Packing QTY.	4pcs
Carton MEAS.	360x260x250mm
Carton G.W.	6.6kg

UE-WL4020 Flood&Area light

Floodlight	Super bright COB LED 1100 / 2200 / 4300 lumens
Color rendering index	80 CRI+
Color temperature	6500K
Power bank output	Max 5V 2A
Battery capacity	High quality 11.1V 5200mAh Li-ion battery
Runtime	6h / 3h / 1h 30mins
Charging time	4h 30mins
Waterproof and dustproof	IP65
Drop resistance rating	IK07
Packing QTY.	4pcs
Carton MEAS.	380x305x275mm
Carton G.W.	7.6kg



UE-WL4027 Lycolor light Quick color controller Motion Sensor Switch

Floodlight	Super bright , high CRI and multi CCT COB LED 300 / 600 / 1200 / 1800 / 2400lm
Color rendering index	96 CRI+
CCT	2700K-3500K-4500K-5500K-6500K
Battery capacity	High quality 11.1V 5200mAh Li-ion battery
Runtime	13h / 6.5h / 3h / 2h / 1.7h
Charging time	3h 30mins
Waterproof and dustproof	IP65
Drop resistance rating	IK07
Packing QTY.	4pcs
Carton MEAS.	33.5x30.5x27cm
Carton G.W.	6.6kg



working lamp



UE-WL4111S

Lycolor light Quick color controller Motion Sensor Switch

Floodlight	Super bright High CRI and three CCT COB LED 250-500 lumens
Color rendering index	96 CRI+
CCT	2700K-4500K-6500K
Battery capacity	High quality 3.7V 2600mAh Li-Po battery
Runtime	2h 30mins
Charging time	4h
Waterproof and dustproof	IP65
Drop resistance rating	IK07
Packing QTY.	12pcs
Carton MEAS.	375x350x210mm
Carton G.W.	7.2kg

UE-WL4118

Lycolor light Quick color controller Motion Sensor Switch

Floodlight	Super bright High CRI and three CCT COB LED 500 / 1000 / 2000 lumens
Color rendering index	96 CRI+
CCT	2700K-3500K-4500K-5500K-6500K
Battery capacity	High quality 11.1V 5200mAh Li-ion battery
Runtime	10h / 4.5h / 2h 20mins
Charging time	3h 30mins
Waterproof and dustproof	IP65
Drop resistance rating	IK07
Packing QTY.	4pcs
Carton MEAS.	360x260x250mm
Carton G.W.	7.7kg

